



Spread Spectrum Clock Generator

AK8125AE

Features

- **Input Frequency:**
 - Crystal: 6.1-36MHz
 - External: 6.1- 49.92MHz
- **Configurable Spread Spectrum Modulation:**
 - **Modulation Ratio:**
 - 0.25%,-0.5%,-0.75%, -1.0%
 - $\pm 0.125\%, \pm 0.25\%, \pm 0.375\%, \pm 0.5\%$
 - **Modulation Frequency**
 - Around 30KHz
- **Low Jitter Performance:**
 - 300 psec (peak) Cycle to Cycle Jitter
 - 600 psec(p-p non-SS) long term
- **Low Current Consumption:**
 - 6.5mA typ.
- **Supply Voltage:**
 - 3.0 – 3.6V
- **Operating Temperature Range:**
 - 20 to +85°C
- **Package:**
 - 10-pin TMSOP
 - Lead Free & Halogen Free

Description

The AK8125A is a spread spectrum clock generator designed for general purpose EMI elimination. The device uses the AKM's original spread spectrum profile to provide excellent EMI reduction effect without degradation of system performance. The device is available in a very small 10-pin TMSOP package, and its pin configuration offers simple PCB layout.

Applications

- HDTV, STB, MFP, etc.

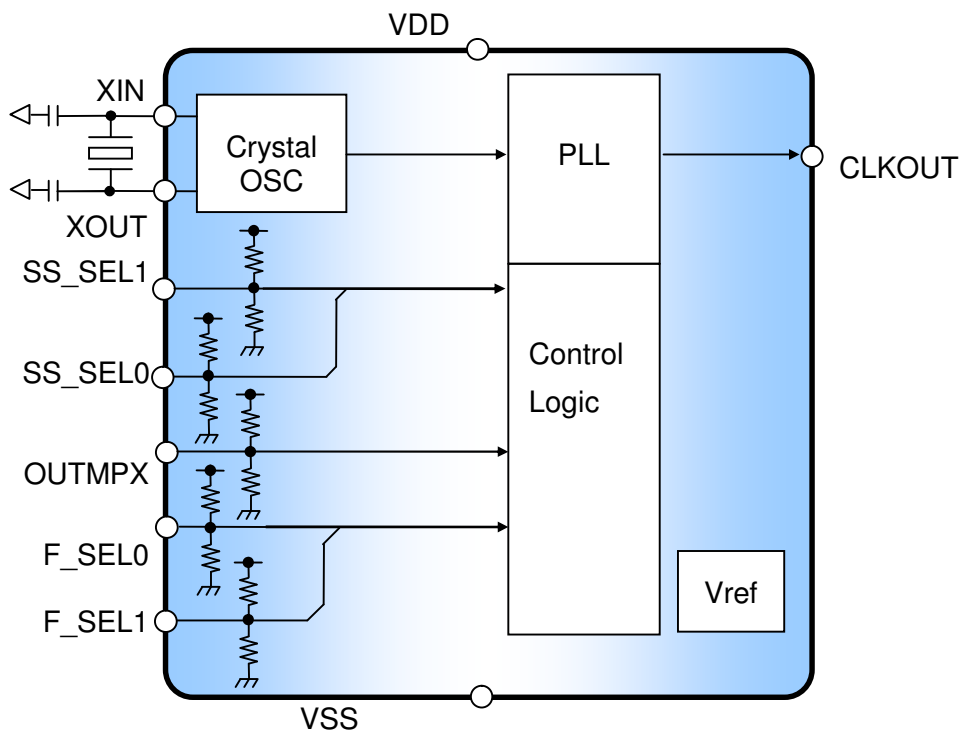

Pin Descriptions

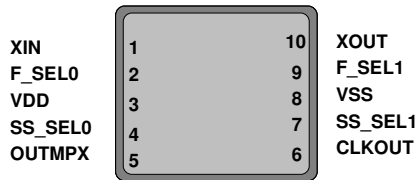

Package: 10-Pin TMSOP (Top View)

Pin No.	Pin Name	Pin Type	Description
1	XIN	IN	Crystal connection pin or Reference clock input pin
2	F_SEL0	IN	Frequency range Select Pin0 (1)
3	VDD	PWR	Power Supply
4	SS_SEL0	IN	Spread Spectrum Modulation Ratio Select Pin0 (1)
5	OUTMPX	IN	x1, x2, x4 Select pin (1)
6	CLKOUT	OUT	Clock Output
7	SS_SEL1	IN	Spread Spectrum Modulation Ratio Select Pin1 (1)
8	VSS	PWR	Ground
9	F_SEL1	IN	Frequency range Select Pin1 (1)
10	XOUT	OUT	Crystal connection pin. Leave this pin floating when the external clock is used.

(1) 3-Level Input for Low/Mid/Hi. Biased at 1/2 of VDD with pull-up/down resistors of 150kΩ (Typ.).

Ordering Information

Part Number	Marking	Shipping Packaging	Package	Temperature Range
AK8125AE	125AE	Tape and Reel	10-pin TMSOP	-20 to 85 °C

Absolute Maximum Rating

Over operating free-air temperature range unless otherwise noted ⁽¹⁾

Items	Symbol	Ratings	Unit
Supply Voltage	VDD	-0.3 to 4.6	V
Input Voltage	V _{in}	VSS-0.3 to VDD+ 0.3	V
Input Current (any pins except supplies)	I _{IN}	± 10	mA
Storage Temperature	T _{stg}	-55 to 130	°C

Note

(1) Stress beyond those listed under “Absolute Maximum Ratings” may cause permanent damage to the device. These are stress ratings only. Functional operation of the device at these or any other conditions beyond those indicated under “Recommended Operating Conditions” is not implied. Exposure to absolute-maximum-rating conditions for extended periods may affect device reliability. Electrical parameters are guaranteed only over the recommended operating temperature range.



ESD Sensitive Device

This device is manufactured on a CMOS process, therefore, generically susceptible to damage by excessive static voltage. Failure to observe proper handling and installation procedures can cause damage. AKM recommends that this device is handled with appropriate precautions.

Recommended Operation Conditions

Parameter	Symbol	Conditions	Min	Typ	Max	Unit
Operating Temperature	T _a		-20		85	°C
Supply Voltage	VDD		3.0	3.3	3.6	V
Input Clock Frequency	F _{in}		6.1		49.92	MHz
Output Load Capacitance	C _{pl}				15	pF

Note:

(1) A decoupling capacitor of 0.1μF for power supply line should be installed close to VDD pin.

DC Characteristics

All specifications at VDD: over 3.0 to 3.6V, Ta: -20 to 85°C, Output Frequency: over specified frequency, unless otherwise noted

Parameter	Symbol	Conditions	MIN	TYP	MAX	Unit
High Level Input Voltage	V _{IH}		0.85VDD			V
Middle Level Input Voltage	V _{IM}		0.35VDD	0.50VDD	0.65VDD	V
Low Level Input Voltage	V _{IL}				0.15VDD	V
Input Current	I _L	Pin: OUTMPX SS_SEL[1:0], F_SEL[1:0]	-40		+40	μA
High Level Output Voltage	V _{OH}	Pin: CLKOUT I _{OH} =-6mA	0.8VDD			V
Low Level Output Voltage	V _{OL}	Pin: CLKOUT I _{OL} =+6mA			0.2VDD	V
Current Consumption	I _{DD}	No load, SS_SEL[1:0]=H/H OUTMPX=M		6.5	10	mA

AC Characteristics

All specifications at VDD: over 3.0 to 3.6V, Ta: -20 to 85°C, Output Frequency: over specified frequency, unless otherwise noted

Parameter	Pins	Conditions	MIN	TYP	MAX	Unit
Crystal Oscillator Frequency	XIN XOUT	AT cut Crystal	6.1		36	MHz
Input Clock duty cycle	XIN		30		70	%
Input Clock Swing	XIN		1			V _{pp}
Output Lock Time ⁽¹⁾	CLKOUT	Power-up		1	5	ms
Settling Time ⁽²⁾	CLKOUT			1	2	ms
Output Clock Duty Cycle	CLKOUT		45	50	55	%
Output Clock Rise Time	CLKOUT	0.2VDD to 0.8VDD		1.5	3.0	ns
Output Clock Fall Time	CLKOUT	0.8VDD to 0.2 VDD		1.5	3.0	ns
Cycle to cycle jitter	CLKOUT	See table 1 Cpl=15pF				ps
Long term jitter	CLKOUT	1000 cycle delay Cpl=15pF,p-p SS_SEL[1:0]="M,M"			600	ps

1. The time that output reaches the target frequency within accuracy of ± 0.1% from the point that the power supply reaches VDD
2. The time that output reaches the target frequency within accuracy of ± 0.1% after SS_SEL[1:0] are affected.

Table 1. Cycle to Cycle Jitter (Peak, Typ./Max.)

Output Frequency	Modulation Ratio		
	SS Off	Down -0.25%, -0.5% Center $\pm 0.125\%$, $\pm 0.25\%$	Down -1.5%, -3.0% Center $\pm 0.75\%$, $\pm 1.5\%$
$6.1\text{MHz} \leq f_{\text{out}} \leq 9.36\text{MHz}$	100ps/300ps	150ps/450ps	700ps/1000ps
$9.36\text{MHz} < f_{\text{out}} \leq 15.6\text{MHz}$			400ps/700ps
$15.6\text{MHz} < f_{\text{out}} \leq 24.96\text{MHz}$			200ps/500ps
$24.96\text{MHz} < f_{\text{out}} \leq 98.98\text{MHz}$			

Definition of Jitters

1. **Cycle to cycle jitter:** The variation in cycle time of a single between adjacent cycles, over a random sample of adjacent cycle pairs.

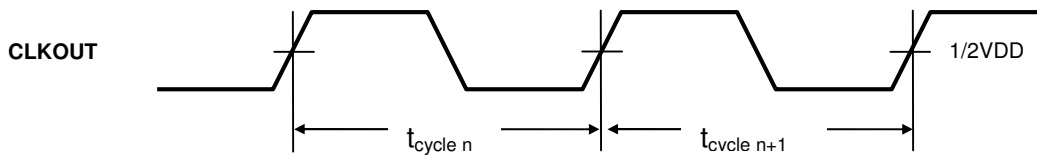

$CCJ = |t_{\text{cycle } n} - t_{\text{cycle } n+1}|$: where $t_{\text{cycle } n}$ and $t_{\text{cycle } n+1}$ are any two adjacent cycles measured on controlled edges.

2. **Long term jitter: 1000Cycles after oscilloscope trigger.**

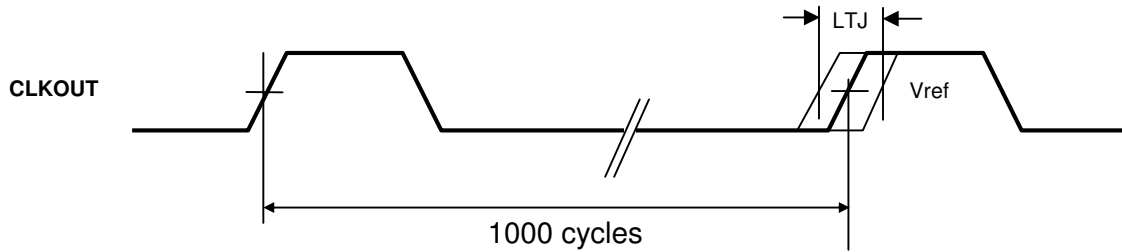

Frequency Characteristics

All specifications at VDD: over 3.0 to 3.6V, Ta:-20 to 85°C, Output Frequency: over specified frequency, unless otherwise noted

Term	Pins	MIN	TYP	MAX	Unit	Pin Setting
Input range	XIN	6.10		8.32	MHz	F_SEL[1:0]=LL
		7.80		10.40		F_SEL[1:0]=LM
		9.36		12.48		F_SEL[1:0]=LH
		12.48		16.64		F_SEL[1:0]=ML
		15.60		20.80		F_SEL[1:0]=MM
		18.72		24.96		F_SEL[1:0]=MH
		24.96		33.28		F_SEL[1:0]=HL
		31.20		41.60		F_SEL[1:0]=HM
		37.44		49.92		F_SEL[1:0]=HH
Output	CKOUT	-	1	-		OUTMPX=L
		-	2	-		OUTMPX=M
		-	4	-		OUTMPX=H, (*1)
Modulation	CKOUT	-	-0.25	-	%	SS_SEL[1:0]=LL
		-	-0.5	-		SS_SEL[1:0]=LM
		-	-1.5	-		SS_SEL[1:0]=LH
		-	-3.0	-		SS_SEL[1:0]=ML
		-	OFF	-		SS_SEL[1:0]=MM
		-	±0.125	-		SS_SEL[1:0]=MH
		-	±0.25	-		SS_SEL[1:0]=HL
		-	±0.75	-		SS_SEL[1:0]=HM
		-	±1.5	-		SS_SEL[1:0]=HH
Average Modulation Frequency Offset ^(b) @Down Spread	CKOUT		-0.18		%	SS_SEL[1:0]=LL, F_SEL0=L
			-0.36			SS_SEL[1:0]=LM, F_SEL0=L
			-0.90			SS_SEL[1:0]=LH, F_SEL0=L
			-1.68			SS_SEL[1:0]=ML, F_SEL0=L
			-0.19			SS_SEL[1:0]=LL, F_SEL0=M
			-0.38			SS_SEL[1:0]=LM, F_SEL0=M
			-0.91			SS_SEL[1:0]=LH, F_SEL0=M
			-1.68			SS_SEL[1:0]=ML, F_SEL0=M
			-0.20			SS_SEL[1:0]=LL, F_SEL0=H
			-0.36			SS_SEL[1:0]=LM, F_SEL0=H
			-0.92			SS_SEL[1:0]=LH, F_SEL0=H
	-1.68		SS_SEL[1:0]=ML, F_SEL0=H			

(*1) Please use 4x setting under output frequency 99.84MHz or less.

(*2) The average output frequency in the mode of down spread modulation is intentionally offset against the ideal average frequency.

Spread Spectrum Modulation Selection

The modulation ration are selectable by pin setting of SS_SEL[1:0] (Pin 7 and 4), as defined in Table1.

Table 2: Modulation Ratio Setting

SS_SEL[1:0]		Spread Mode
1	0	
L	L	-0.25%
L	M	-0.5%
L	H	-1.5%
M	L	-3.0%
M	M	SS Off
M	H	±0.125%
H	L	±0.25%
H	M	±0.75%
H	H	±1.5%

Operation frequency Range Selection

The operation frequency range are selectable by pin setting of F_SEL[1:0] (Pin 9 and 2), as defined in Table3.

Table 3: Operation Frequency Table

F_SEL[1:0]		Input Range	Output Range (OUTMPX="L")	Output Range (OUTMPX="M")	Output Range (OUTMPX="H")
1	0				
L	L	6.1 - 8.32MHz	6.1 - 8.32MHz	12.2 – 16.64MHz	24.4 – 33.28MHz
L	M	7.80 - 10.40MHz	7.80 - 10.40MHz	15.60 - 20.80MHz	31.20 – 41.60MHz
L	H	9.36 - 12.48MHz	9.36 - 12.48MHz	18.72 – 24.96MHz	37.44 – 49.92MHz
M	L	12.48 - 16.64MHz	12.48 - 16.64MHz	24.96 – 33.28MHz	49.92 – 66.56MHz
M	M	15.60 - 20.80MHz	15.60 - 20.80MHz	31.20 – 41.60MHz	62.40 – 83.20MHz
M	H	18.72 - 24.96MHz	18.72 - 24.96MHz	37.44 – 49.92MHz	74.88 – 99.84MHz
H	L	24.96 - 33.28MHz	24.96 - 33.28MHz	49.92 – 66.56MHz	—
H	M	31.20 - 41.60MHz	31.20 - 41.60MHz	62.40 – 83.20MHz	—
H	H	37.44 - 49.92MHz	37.44 - 49.92MHz	74.88 – 99.84MHz	—

Package Information

• Mechanical data

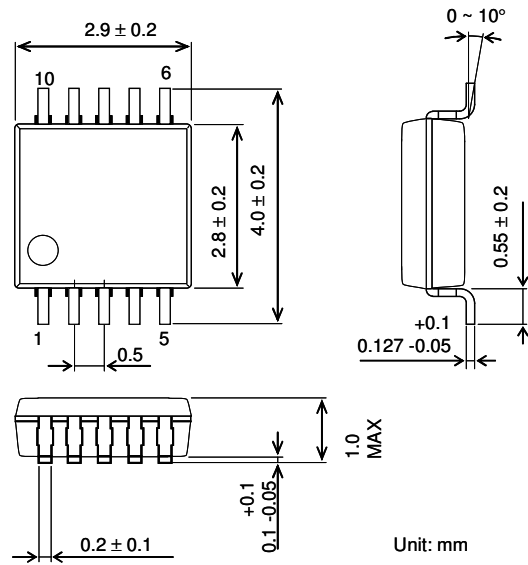

• Marking

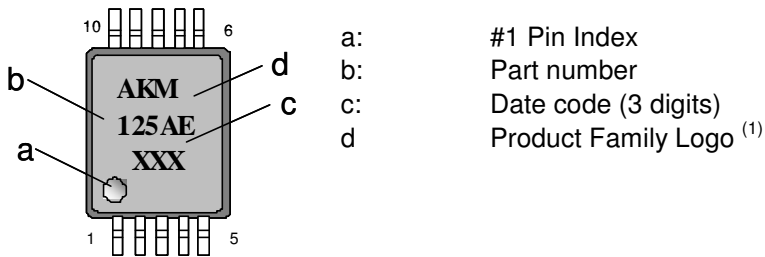

• RoHS Compliance



All integrated circuits from Asahi Kasei Microdevices Corporation (AKM) assembled in “lead-free” packages* are fully compliant with RoHS.

(*) RoHS compliant products from AKM are identified with “Pb free” letter indication on product label posted on the anti-shield bag and boxes.

IMPORTANT NOTICE

- | These products and their specifications are subject to change without notice. When you consider any use or application of these products, please make inquiries the sales office of Asahi Kasei Microdevices Corporation (AKM) or authorized distributors as to current status of the products.
- | AKM assumes no liability for infringement of any patent, intellectual property, or other rights in the application or use of any information contained herein.
- | Any export of these products, or devices or systems containing them, may require an export license or other official approval under the law and regulations of the country of export pertaining to customs and tariffs, currency exchange, or strategic materials.
- | AKM products are neither intended nor authorized for use as critical components^{Note1)} in any safety, life support, or other hazard related device or system^{Note2)}, and AKM assumes no responsibility for such use, except for the use approved with the express written consent by Representative Director of AKM. As used here:
 - Note1) A critical component is one whose failure to function or perform may reasonably be expected to result, whether directly or indirectly, in the loss of the safety or effectiveness of the device or system containing it, and which must therefore meet very high standards of performance and reliability.
 - Note2) A hazard related device or system is one designed or intended for life support or maintenance of safety or for applications in medicine, aerospace, nuclear energy, or other fields, in which its failure to function or perform may reasonably be expected to result in loss of life or in significant injury or damage to person or property.
- | It is the responsibility of the buyer or distributor of AKM products, who distributes, disposes of, or otherwise places the product with a third party, to notify such third party in advance of the above content and conditions, and the buyer or distributor agrees to assume any and all responsibility and liability for and hold AKM harmless from any and all claims arising from the use of said product in the absence of such notification.