

**AsahiKASEI**

ASAHI KASEI EMD

**AK4631****16-Bit  $\Delta\Sigma$  Mono CODEC with ALC & MIC/SPK-AMP****GENERAL DESCRIPTION**

The AK4631 is a 16-bit mono CODEC with Microphone-Amplifier and Speaker-Amplifier. Input circuits include a Microphone-Amplifier and an ALC (Automatic Level Control) circuit. Output circuits include a Speaker-Amplifier and Mono Line Output. The AK4631 suits a moving picture of Digital Still Camera and etc. This speaker-Amplifier supports a Piezo Speaker. The AK4631 is housed in a space-saving 28-pin QFN package.

**FEATURE**

1. 16-Bit Delta-Sigma Mono CODEC
2. Recording Function
  - 1ch Mono Input
  - 1<sup>st</sup> MIC Amplifier: 0dB, 20dB, 26dB or 32dB
  - 2<sup>nd</sup> Amplifier with ALC: -8dB ~ +27.5dB, 0.5dB Step
  - ADC Performance: S/(N+D): 80dB, DR, S/N: 85dB
3. Playback Function
  - Digital Volume: +12dB ~ -115dB, 0.5dB Step, Mute
  - Mono Line Output Performance: S/(N+D): 85dB, S/N: 93dB
  - Mono Speaker-Amp
    - Speaker-Amp Performance: S/(N+D): 50dB, S/N: 90dB (240mW @ 8 $\Omega$ )
    - BTL Output
    - ALC (Automatic Level Control) Circuit
    - Output Power: 250mW @ 8 $\Omega$ , SVDD=3.3V  
3.0Vrms@SVDD=5V
  - Beep Input
4. Power Management
5. Flexible PLL Mode:
  - Frequencies:
    - 11.2896MHz, 12MHz, 12.288MHz, 13.5MHz, 24MHz, 27MHz (MCKI pin)
    - 1fs (FCK pin)
    - 16fs, 32fs or 64fs (BICK pin)
6. EXT Mode:
  - Frequencies: 256fs, 512fs or 1024fs (MCKI pin)
7. Sampling Rate:
  - PLL Slave Mode (FCK pin): 7.35kHz ~ 26kHz
  - PLL Slave Mode (BICK pin): 7.35kHz ~ 48kHz
  - PLL Slave Mode (MCKI pin):
    - 8kHz, 11.025kHz, 12kHz, 16kHz, 22.05kHz, 24kHz, 32kHz, 44.1kHz, 48kHz
  - PLL Master Mode:
    - 8kHz, 11.025kHz, 12kHz, 16kHz, 22.05kHz, 24kHz, 32kHz, 44.1kHz, 48kHz
  - EXT Slave Mode:
    - 7.35kHz ~ 48kHz (256fs), 7.35kHz ~ 26kHz (512fs), 7.35kHz ~ 13kHz (1024fs)
8. Output Master Clock Frequency: 256fs
9. Serial  $\mu$ P Interface: 3-wire
10. Master / Slave Mode

11. Audio Interface Format: MSB First, 2's complement
  - ADC: DSP Mode, 16bit MSB justified, I<sup>2</sup>S
  - DAC: DSP Mode, 16bit MSB justified, 16bit LSB justified, I<sup>2</sup>S
12. Ta = -10 ~ 70°C
13. Power Supply
  - CODEC: 2.6 ~ 3.6V (typ. 3.3V)
  - Speaker-Amp: 2.6 ~ 5.25V (typ. 3.3V/5.0V)
14. Power Supply Current: 16mA (All Power ON)
15. Package: 28pin QFN
16. Pin and Register Compatible with AK4536/AK4630

## ■ Block Diagram

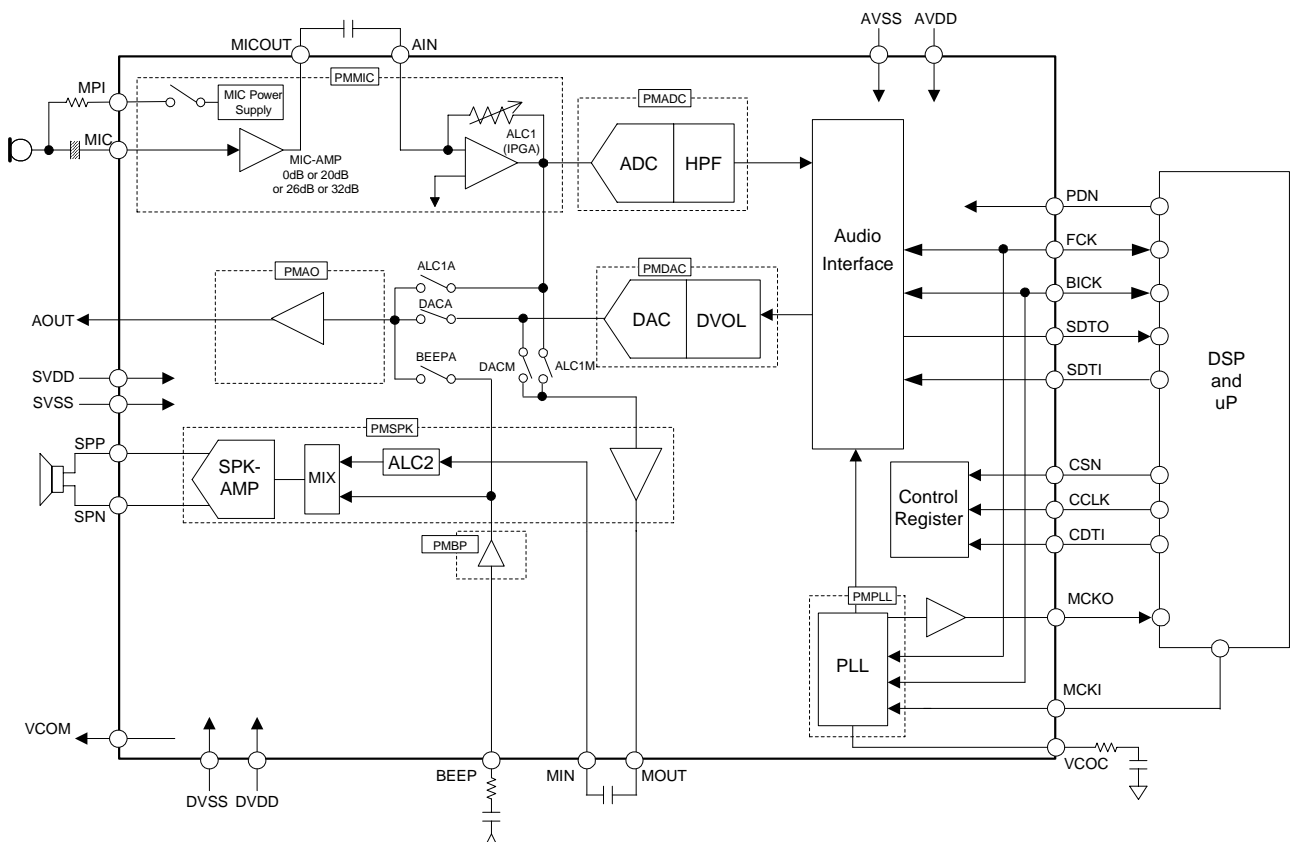

Figure 1. AK4631 Block Diagram

■ Ordering Guide

AK4631VN  
AKD4631

-10 ~ +70°C                      28pin QFN (0.5mm pitch)  
Evaluation board for AK4631

■ Pin Layout

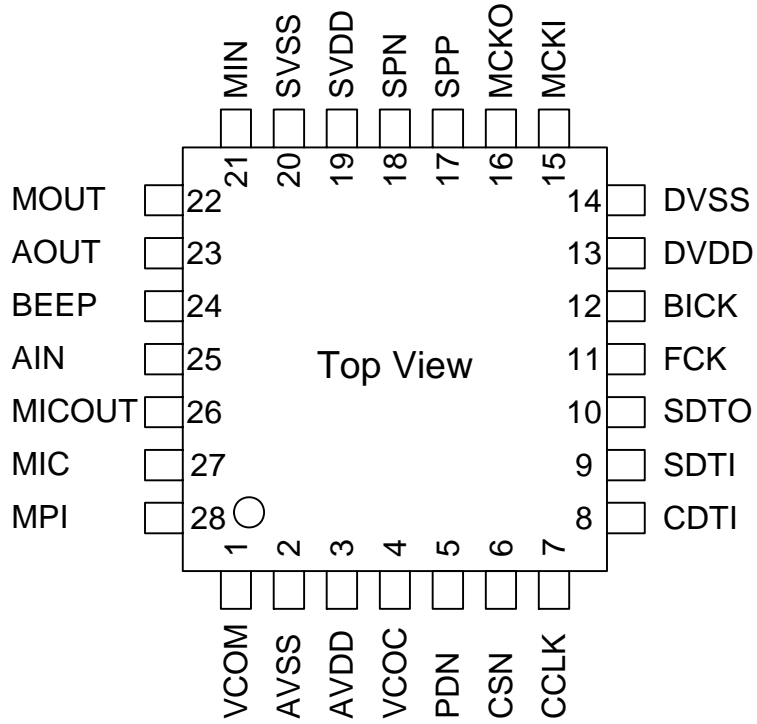

## ■ Compare AK4536/AK4630 with AK4631

In the case of using the AK4536 or the AK4630, it will be possible to change to the AK4631 from the AK4536 or the AK4630 without modifying the software and the design circuit except the items shown by shading in the following compatibility.

### 1. Function

Function	AK4536VN	AK4630VN	AK4631VN
<b>Dynamic Speaker</b>			
AVDD, DVDD, SVDD	2.4V ~ 3.6V	2.4V ~ 3.6V	2.6V ~ 3.6V
SPK-Amp Output Voltage at ALC2 OFF and AVDD=DVDD=SVDD=3.3V	2 mode 150mW@8Ω 250mW@8Ω	2 mode 150mW@8Ω 250mW@8Ω	4 mode 150mW@8Ω 250mW@8Ω +4.2dB from 250mW mode +6.2dB from 250mW mode
SPK-Amp Output Voltage At ALC2 ON and AVDD=DVDD=SVDD=3.3V	2 mode 150mW@8Ω 250mW@8Ω	2 mode 150mW@8Ω 250mW@8Ω	2 mode 150mW@8Ω 240mW@8Ω
<b>Piezo Speaker</b>			
AVDD, DVDD	Not Available	Not Available	2.6V ~ 3.6V
SVDD			2.6V ~ 5.25V
SPK-Amp Output Voltage			4 mode
<b>Others</b>			
X'tal Oscillator	Yes	No	No
MCKI pin AC Coupling Input	Yes	No	No
Master Clock Output	No	Yes	Yes
Reference Value at ALC2 Recovery Operation	Fixed : +18dB	Fixed : +18dB	Variable : +19.5dB~-12.0dB
Sampling Rate	7.35kHz ~ 26kHz	7.35kHz ~ 26kHz	7.35kHz ~ 48kHz
MIC Amp Gain	0dB/+20dB	0dB/+20dB	0dB/+20dB/+26dB/+32dB
Soft Transition Time of Output Digital Volume	1061/fs	1061/fs	1061/fs or 256/fs
Master Clock for PLL	11.2896MHz, 12MHz, 12.288MHz	11.2896MHz, 12MHz, 12.288MHz	11.2896MHz, 12MHz, 12.288MHz, 13.5MHz, 24MHz, 27MHz
Mute Function of AOUT	No	No	Yes
Output of AOUT pin in power down mode	Hi-Z	Hi-Z	AVSS
BEEP → SPP/SPN Gain (External Input Resistance = 20kΩ)	+6dB at SPKG bit = "0"	+6dB at SPKG bit = "0"	+7.84 dB at SPKG1-0 bits = "00"
R and C of VCOC pin at PLL reference clock = FCK pin.	10kΩ + 470nF	10kΩ + 470nF	6.8kΩ + 220nF
Audio I/F Format at PLL Master Mode	Only DSP Mode	All Modes	All Modes
Audio I/F Format at PLL Slave Mode	Only DSP Mode	All Modes	All Modes
FCK Pulse width "H" at PLL Master Mode	1/tBCK	50% duty	50% duty
The size of the black part at four corners in package diagram	0.2 <sup>+0.10</sup> <sub>-0.20</sub> mm	0.55 ± 0.20 mm	0.55 ± 0.20 mm
The minimum height of package	0.80 mm	0.70 mm	0.70 mm
The thickness of package except lead frame	0.78 <sup>+0.17</sup> <sub>-0.28</sub>	No Spec	No Spec

Function	AK4536VN	AK4630VN	AK4631VN	
<b>Mono Line Output Characteristics</b>				
D-Range (typ)	95dB	95dB	93dB	
S/N(typ)	95dB	95dB	93dB	
<b>Speaker-Amp Characteristics</b>				
Output Voltage (at -0.5dBFS)				
SPKG1-0 bits = "00" (typ)	2.92Vpp	2.92Vpp	3.09Vpp	
SPKG1-0 bits = "01" (typ)	3.78Vpp	3.78Vpp	3.92Vpp	
S/(N+D) (at 240mW) SPKG1-0 bits = "01" (typ)	-	-	50dB	
S/(N+D) (at 250mW) SPKG1-0 bits = "01" (typ)	50dB	50dB	20dB	
<b>ADC Digital Filter (HPF) Characteristics: fs=8kHz</b>				
Frequency Response (typ)	-3.0dB	1.25Hz	1.25 Hz	0.62 Hz
	-0.5dB	3.56 Hz	3.56 Hz	1.81 Hz
	-0.1dB	8.14 Hz	8.14 Hz	3.99 Hz

Note 1. The black part of the AK4631 is wider than that of the AK4536. Check if this black parts are open without contacting trace line and GND. Refer to "PACKAGE".

## 2. Pin Layout

Pin No.	AK4536VN	AK4630VN	AK4631VN
# 15	MCKI / XTI	MCKI	MCKI
# 16	XTO	MCKO	MCKO

### 3. Register

#### (1) Register Map

Addr	Register Name	D7	D6	D5	D4	D3	D2	D1	D0
00H	Power Management 1	0	PMVCM	PMBP	PMSPK	PMAO	PMDAC	PMMIC	PMADC
01H	Power Management 2	0	0	0	0	M/S	MCKPD	MCKO	PMPLL
02H	Signal Select 1	SPPS	BEEPS	ALC2S	DACA	DACM	MPWR	MICAD	MGAIN0
03H	Signal Select 2	0	<b>AOPSN</b>	<b>MGAIN1</b>	<b>SPKG1</b>	SPKG0	BEEPA	ALC1M	ALC1A
04H	Mode Control 1	<b>PLL3</b>	PLL2	PLL1	PLL0	BCKO1	BCKO0	DIF1	DIF0
05H	Mode Control 2	0	0	<b>FS3</b>	MSBS	BCKP	FS2	<b>FS1</b>	<b>FS0</b>
06H	Timer Select	<b>DVTM</b>	ROTM	ZTM1	ZTM0	WTM1	WTM0	LTM1	LTM0
07H	ALC Mode Control 1	0	ALC2	ALC1	ZELM	LMAT1	LMAT0	RATT	LMTH
08H	ALC Mode Control 2	0	REF6	REF5	REF4	REF3	REF2	REF1	REF0
09H	Input PGA Control	0	IPGA6	IPGA5	IPGA4	IPGA3	IPGA2	IPGA1	IPGA0
0AH	Digital Volume Control	DVOL7	DVOL6	DVOL5	DVOL4	DVOL3	DVOL2	DVOL1	DVOL0
<b>0BH</b>	<b>ALC2 Mode Control</b>	<b>0</b>	<b>0</b>	<b>RFS5</b>	<b>RFS4</b>	<b>RFS3</b>	<b>RFS2</b>	<b>RFS1</b>	<b>RFS0</b>

Register bits changed from the AK4536 or the AK4630.

**Bold** Register bits added from the AK4536 and the AK4630.

#### (2) MCKO bit (Addr = 01H, D1 bit)

Register	AK4536	AK4630/AK4631
Addr = 01H, D1	PMXTL bit	MCKO bit 0: "L" output (default) 1: 256fs output

#### (3) FS1-0 bits (Addr = 05H, D1-0 bits)

When PLL reference clock input is FCK or BICK pin, the setting of FS3-0 bits are changed as shown in the following table.

Mode	FS3 bit	FS2 bit	FS1 bit	FS0 bit	Sampling Frequency Range	
					AK4536/AK4630	AK4631
0	0	Don't care	0	0	7.35kHz ≤ fs ≤ 10kHz	7.35kHz ≤ fs ≤ 8kHz
1	0	Don't care	0	1	10kHz < fs ≤ 14kHz	8kHz < fs ≤ 12kHz
2	0	Don't care	1	0	14kHz < fs ≤ 20kHz	12kHz < fs ≤ 16kHz
3	0	Don't care	1	1	20kHz < fs ≤ 26kHz	16kHz < fs ≤ 24kHz
6	1	Don't care	1	0	N/A	24kHz < fs ≤ 32kHz
7	1	Don't care	1	1	N/A	32kHz < fs ≤ 48kHz
Others	Others				N/A	N/A

When the sampling rate is 8kHz, 11.025kHz, 16kHz, 22.05kHz and 24kHz, the FS3-0 bits setting of the AK4631 is same as that of the AK4536 and the AK4630.

**PIN/FUNCTION**

No.	Pin Name	I/O	Function
1	VCOM	O	Common Voltage Output Pin, 0.45 x AVDD Bias voltage of ADC inputs and DAC outputs.
2	AVSS	-	Analog Ground Pin
3	AVDD	-	Analog Power Supply Pin
4	VCOC	O	Output Pin for Loop Filter of PLL Circuit This pin should be connected to AVSS with one resistor and capacitor in series.
5	PDN	I	Power-Down Mode Pin “H”: Power up, “L”: Power down reset and initialize the control register.
6	CSN	I	Chip Select Pin
7	CCLK	I	Control Data Clock Pin
8	CDTI	I	Control Data Input Pin
9	SDTI	I	Audio Serial Data Input Pin
10	SDTO	O	Audio Serial Data Output Pin
11	FCK	I/O	Frame Clock Pin
12	BICK	I/O	Audio Serial Data Clock Pin
13	DVDD	-	Digital Power Supply Pin
14	DVSS	-	Digital Ground Pin
15	MCKI	I	External Master Clock Input Pin (Internal Pull Down 25kΩ@PDN pin =“L”)
16	MCKO	O	Master Clock Output Pin
17	SPP	O	Speaker Amp Positive Output Pin
18	SPN	O	Speaker Amp Negative Output Pin
19	SVDD	-	Speaker Amp Power Supply Pin
20	SVSS	-	Speaker Amp Ground Pin
21	MIN	I	ALC2 Input Pin
22	MOUT	O	Mono Analog Output Pin
23	AOUT	O	Mono Line Output Pin
24	BEEP	I	Beep Signal Input Pin
25	AIN	I	IPGA (ALC1) Input Pin
26	MICOUT	O	Microphone Analog Output Pin
27	MIC	I	Microphone Input Pin (Mono Input)
28	MPI	O	MIC Power Supply Pin for Microphone

Note: All input pins except analog input pins (MIC, AIN, MIN and BEEP pins) should not be left floating.

**■ Handling of Unused Pin**

The unused I/O pins should be processed appropriately as below.

Classification	Pin Name	Setting
Analog Input	MIC, AIN, BEEP, MIN	These pins should be open and each path should be switched off.
Analog Output	MICOUT, MPI, AOUT, MOUT, SPP, SPN	These pins should be open.
Digital Input	MCKI, SDTI, FCK(when M/S bit = “0”), BICK(when M/S bit = “0”)	These pins should be connected to DVSS.
Digital Output	MCKO, SDTO, FCK(when M/S bit = “1”), BICK(when M/S bit = “1”)	These pins should be open.

<b>ABSOLUTE MAXIMUM RATINGS</b>
---------------------------------

(AVSS=DVSS=SVSS=0V; Note 2)

Parameter		Symbol	min	max	Units
Power Supplies:	Analog	AVDD	-0.3	6.0	V
	Digital	DVDD	-0.3	6.0	V
	Speaker-Amp	SVDD	-0.3	6.0	V
	AVSS – DVSS  (Note 3)	ΔGND1	-	0.3	V
	AVSS – SVSS  (Note 3)	ΔGND2	-	0.3	V
Input Current, Any Pin Except Supplies		IIN	-	±10	mA
Analog Input Voltage		VINA	-0.3	AVDD+0.3	V
Digital Input Voltage		VIND	-0.3	DVDD+0.3	V
Ambient Temperature (powered applied)		Ta	-10	70	°C
Storage Temperature		Tstg	-65	150	°C
Maximum Power Dissipation (Note 4)		Pd	-	520	mW

Note 2. All voltages with respect to ground.

Note 3. AVSS, DVSS and SVSS must be connected to the same analog ground plane.

Note 4. In case that PCB wiring density is 100%. This power is the AK4631 internal dissipation that does not include power of externally connected speaker.

WARNING: Operation at or beyond these limits may result in permanent damage to the device.  
Normal operation is not guaranteed at these extremes.

<b>RECOMMENDED OPERATING CONDITIONS</b>
---

(AVSS=DVSS=SVSS=0V; Note 2)

Parameter		Symbol	min	typ	max	Units
Power Supplies (Note 5)	Analog	AVDD	2.6	3.3	3.6	V
	Digital	DVDD	2.6	3.3	3.6	V
	Speaker-Amp (Note 6)	SVDD	2.6	3.3 / 5.0	5.25	V
	Difference	AVDD-DVDD	-0.3	0	0.3	V

Note 2. All voltages with respect to ground

Note 5. The power up sequence between AVDD, DVDD and SVDD is not critical.

When the power supplies are partially powered OFF, the AK4631 must be reset by bringing the PDN pin “L” after these power supplies are powered ON again.

Note 6. SVDD = 2.6 ~ 3.6V when 8Ω dynamic speaker is connected to the AK4631.

\* AKEMD assumes no responsibility for the usage beyond the conditions in this datasheet.

### ANALOG CHARACTERISTICS

(Ta=25°C; AVDD=DVDD=SVDD=3.3V; AVSS=DVSS=SVSS=0V; fs=8kHz, BICK=64fs; Signal Frequency=1kHz; 16bit Data; Measurement frequency=20Hz ~ 3.4kHz; EXT Slave Mode; unless otherwise specified)

Parameter	min	typ	max	Units	
<b>MIC Amplifier</b>					
Input Resistance	20	30	40	kΩ	
Gain (MGAIN1-0 bits = "00") (MGAIN1-0 bits = "01") (MGAIN1-0 bits = "10") (MGAIN1-0 bits = "11")	-	0	-	dB	
	-	20	-	dB	
	-	26	-	dB	
	-	32	-	dB	
<b>MIC Power Supply: MPI pin</b>					
Output Voltage (Note 7)	2.22	2.47	2.72	V	
Load Resistance	2	-	-	kΩ	
Load Capacitance	-	-	30	pF	
<b>Input PGA Characteristics:</b>					
Input Resistance (Note 8)	5	10	15	kΩ	
Step Size	0.05	0.5	0.9	dB	
Gain Control Range	-8	-	+27.5	dB	
<b>ADC Analog Input Characteristics: MIC → IPGA → ADC, MIC Gain=20dB, IPGA=0dB, ALC1=OFF</b>					
Resolution			16	Bits	
Input Voltage (MIC Gain=20dB, Note 9)	0.168	0.198	0.228	Vpp	
S/(N+D) (-1dBFS) (Note 10)	68	80	-	dB	
D-Range (-60dBFS)	75	85	-	dB	
S/N	75	85	-	dB	
<b>DAC Characteristics:</b>					
Resolution			16	Bits	
<b>Mono Line Output Characteristics: AOUT pin, DAC → AOUT, RL=10kΩ</b>					
Output Voltage (Note 11)	1.78	1.98	2.18	Vpp	
S/(N+D) (0dBFS) (Note 10)	73	85	-	dB	
D-Range (-60dBFS)	83	93	-	dB	
S/N	83	93	-	dB	
Load Resistance	10	-	-	kΩ	
Load Capacitance	-	-	30	pF	
<b>Speaker-Amp Characteristics: SPP/SPN pins, MIN → SPP/SPN, ALC2=OFF, RL=8Ω, BTL, SVDD=3.3V</b>					
Output Voltage (Note 12)	SPKG1-0 bits = "00" (-0.5dBFS)	2.47	3.09	3.71	Vpp
	SPKG1-0 bits = "01" (-0.5dBFS)	3.10	4.00	4.80	Vpp
S/(N+D)	SPKG1-0 bits = "00" (at 150mW)	40	60	-	dB
	SPKG1-0 bits = "01" (at 240mW)	20	50	-	dB
	SPKG1-0 bits = "01" (at 250mW)	-	20	-	dB
S/N (Note 14)	80	90	-	dB	
Load Resistance	8	-	-	Ω	
Load Capacitance	-	-	30	pF	
<b>Speaker-Amp Characteristics: MIN → SPP/SPN pins, ALC2=OFF, CL=3μF, Rserial=10Ω x 2, BTL, SVDD=5.0V</b>					
Output Voltage (Note 12)	SPKG1-0 bits = "10" (0dBFS)	-	6.72	-	Vpp
	SPKG1-0 bits = "11" (0dBFS)	6.80	8.50	10.20	Vpp
S/(N+D) (Note 12) (Note 13)	SPKG1-0 bits = "10" (0dBFS)	-	60	-	dB
	SPKG1-0 bits = "11" (0dBFS)	20	50	-	dB
S/N (Note 13) (Note 14)	80	90	-	-	
Load Impedance (Note 15)	50	-	-	Ω	
Load Capacitance	-	-	3	μF	

Parameter	min	typ	max	Units
<b>BEEP Input:</b> BEEP pin, External Input Resistance= 20kΩ				
Maximum Input Voltage (Note 16)	-	1.98	-	Vpp
Output Voltage (Input Voltage=0.6Vpp)				
BEEP → SPP/SPN (SPKG1-0 bits = "00")	0.74	1.48	2.22	Vpp
BEEP → AOUT	0.3	0.6	0.9	Vpp
<b>Mono Input:</b> MIN pin				
Maximum Input Voltage (Note 17)	-	2.18	-	Vpp
Input Resistance (Note 18)	12	24	36	kΩ
<b>Mono Output:</b> MOUT pin, DAC→ MOUT				
Output Voltage (Note 19)	1.78	1.98	2.18	Vpp
Load Resistance	10	-	-	kΩ
Load Capacitance	-	-	30	pF
<b>Power Supplies</b>				
Power Up (PDN pin = "H")				
All Circuit Power-up: (Note 20)				
AVDD+DVDD				
fs=8kHz	-	9	-	mA
fs=48kHz	-	11.5	17.5	mA
SVDD: Speaker-Amp Normal Operation (SPPS bit = "1", No Output)				
SVDD=3.3V	-	7	-	mA
SVDD=5.0V	-	9	27	mA
Power Down (PDN pin = "L")				
AVDD+DVDD+SVDD	-	10	200	μA

Note 7. Output voltage is proportional to AVDD voltage.  $V_{out} = 0.75 \times AVDD$  (typ)

Note 8. When IPGA Gain is changed, this typical value changes between 8kΩ and 11kΩ.

Note 9. Input voltage is proportional to AVDD voltage.  $V_{in} = 0.06 \times AVDD$  (typ)

Note 10. When a PLL reference clock is FCK pin in PLL Slave Mode, S/(N+D) is 77dB (typ).

Note 11. Output voltage is proportional to AVDD voltage.  $V_{out} = 0.6 \times AVDD$  (typ)

Note 12. The full scale of Input signal of MIN pin is 1.98Vpp.

Note 13. In case of measuring between SPP pin and SPN pin directly.

Note 14. There are no relations with the setup of SPKG1-0 bits, and it is the same value.

Note 15. Load impedance is total impedance of series resistance and piezo speaker impedance at 1kHz in Figure 34. Load capacitance is capacitance of piezo speaker. When piezo speaker is used, 10Ω or more series resistors should be connected at both SPP and SPN pins, respectively.

Note 16. The maximum input voltage of the BEEP is proportional to AVDD voltage and external input resistance( $R_{in}$ ).  
 $V_{out} = 0.6 \times AVDD \times R_{in}/20k\Omega(\max)$ .

Note 17. Maximum Input Voltage is proportional to AVDD voltage.  $V_{in} = 0.66 \times AVDD$  (max)

Note 18. When ALC2 Gain is changed, this typical value changes between 22kΩ and 26kΩ.

Note 19. Output Voltage is proportional to AVDD voltage.  $V_{out} = 0.6 \times AVDD$  (typ)

Note 20. PLL Master Mode (MCKI = 12.288MHz) and PMMIC = PMADC = PMDAC = PMSPK = PMVCM = PMPLL = MCKO = PMAO = PMBP = M/S = "1". And output current from MPI pin is 0mA. When the AK4631 is EXT mode (PMPLL = MCKO = M/S = "0"), "AVDD+DVDD" is typically 7mA@fs=8kHz, 9.5mA@fs=48kHz).

**FILTER CHARACTERISTICS**

(Ta = 25°C; AVDD=DVDD = 2.6 ~ 3.6V; SVDD =2.6 ~ 5.25V; fs=8kHz)

Parameter	Symbol	min	typ	max	Units
<b>ADC Digital Filter (Decimation LPF):</b>					
Passband (Note 21)	±0.16dB	PB	0	3.0	kHz
	-0.66dB		-	3.5	kHz
	-1.1dB		-	3.6	kHz
	-6.9dB		-	4.0	kHz
Stopband (Note 21)	SB	4.7			kHz
Passband Ripple	PR			±0.1	dB
Stopband Attenuation	SA	73			dB
Group Delay (Note 22)	GD		17.1		1/fs
Group Delay Distortion	ΔGD		0		μs
<b>ADC Digital Filter (HPF):</b>					
Frequency Response (Note 21)	-3.0dB	FR	-	0.62	Hz
	-0.5dB		-	1.81	Hz
	-0.1dB		-	3.99	Hz
<b>DAC Digital Filter:</b>					
Passband (Note 21)	±0.1dB	PB	0	3.6	kHz
	-0.7dB		-	3.6	kHz
	-6.0dB		-	4.0	kHz
Stopband (Note 21)	SB	4.6			kHz
Passband Ripple	PR			±0.01	dB
Stopband Attenuation	SA	59			dB
Group Delay (Note 22)	GD		16.8		1/fs
<b>DAC Digital Filter + Analog Filter:</b>					
Frequency Response: 0 ~ 3.4kHz	FR		±1.0		dB

Note 21. The passband and stopband frequencies are proportional to fs (system sampling rate).

For example, ADC is PB=0.45\*fs (@-1.1dB). A reference of frequency response is 1kHz.

Note 22. The calculated delay time caused by digital filtering. This time is from the input of analog signal to setting of the 16-bit data of a channel from the input register to the output register of the ADC. This time includes the group delay of the HPF. For the DAC, this time is from setting the 16-bit data of a channel from the input register to the output of analog signal.

**DC CHARACTERISTICS**

(Ta = 25°C; AVDD=DVDD = 2.6 ~ 3.6V; SVDD =2.6 ~ 5.25V)

Parameter	Symbol	min	typ	max	Units
High-Level Input Voltage	VIH	70%DVDD	-	-	V
Low-Level Input Voltage	VIL	-	-	30%DVDD	V
High-Level Output Voltage (Iout=-80μA)	VOH	DVDD-0.4	-	-	V
Low-Level Output Voltage (Iout= 80μA)	VOL	-	-	0.4	V
Input Leakage Current	Iin	-	-	±10	μA

**SWITING CHARACTERISTICS**

(Ta = 25°C; AVDD=DVDD = 2.6 ~ 3.6V; SVDD =2.6 ~ 5.25V; CL=20pF)

Parameter	Symbol	min	typ	max	Units
<b>PLL Master Mode (PLL Reference Clock = MCKI pin) (Figure 2)</b>					
MCKI Input: Frequency	fCLK	11.2896		27.0	MHz
Pulse Width Low	tCLKL	0.4/fCLK			ns
Pulse Width High	tCLKH	0.4/fCLK			ns
MCKO Output:					
Frequency	fMCK		256 x fFCK		kHz
Duty Cycle except fs=29.4kHz, 32kHz	dMCK	40	50	60	%
fs=29.4kHz, 32kHz (Note 23)	dMCK		33		%
FCK Output: Frequency	fFCK	8		48	kHz
Duty Cycle	dFCK		50		%
BICK: Period (BCKO1-0 = "00")	tBCK		1/16fFCK		ns
(BCKO1-0 = "01")	tBCK		1/32fFCK		ns
(BCKO1-0 = "10")	tBCK		1/64fFCK		ns
Duty Cycle	dBCK		50		%
<b>Audio Interface Timing</b>					
<b>DSP Mode: (Figure 3, Figure 4)</b>					
FCK "↑" to BICK "↑" (Note 24)	tDBF	0.5 x tBCK -40	0.5 x tBCK	0.5 x tBCK + 40	ns
FCK "↑" to BICK "↓" (Note 25)	tDBF	0.5 x tBCK -40	0.5 x tBCK	0.5 x tBCK +40	ns
BICK "↑" to SDTO (BCKP = "0")	tBSD	-70		70	ns
BICK "↓" to SDTO (BCKP = "1")	tBSD	-70		70	ns
SDTI Hold Time	tSDH	50			ns
SDTI Setup Time	tSDS	50			ns
<b>Except DSP Mode: (Figure 5)</b>					
BICK "↓" to FCK Edge	tBFCK	-40		40	ns
FCK to SDTO (MSB) (Except I <sup>2</sup> S mode)	tFSD	-70		70	ns
BICK "↓" to SDTO	tBSD	-70		70	ns
SDTI Hold Time	tSDH	50			ns
SDTI Setup Time	tSDS	50			ns

Parameter	Symbol	min	typ	max	Units
<b>PLL Slave Mode (PLL Reference Clock: FCK pin) (Figure 6, Figure 7)</b>					
FCK: Frequency	fFCK	7.35	8	26	kHz
DSP Mode: Pulse Width High	tFCKH	tBCK-60		1/fFCK-tBFCK	ns
Except DSP Mode: Duty Cycle	duty	45		55	%
BICK: Period	tBCK	1/64fFCK		1/16fFCK	ns
Pulse Width Low	tBCKL	240			ns
Pulse Width High	tBCKH	240			ns
<b>PLL Slave Mode (PLL Reference Clock: BICK pin) (Figure 6, Figure 7)</b>					
FCK: Frequency	fFCK	7.35	8	48	kHz
DSP Mode: Pulse width High	tFCKH	tBCK-60		1/fFCK-tBFCK	ns
Except DSP Mode: Duty Cycle	duty	45		55	%
BICK: Period (PLL3-0 = "0001")	tBCK		1/16fFCK		ns
(PLL3-0 = "0010")	tBCK		1/32fFCK		ns
(PLL3-0 = "0011")	tBCK		1/64fFCK		ns
Pulse Width Low	tBCKL	0.4 x tBCK			ns
Pulse Width High	tBCKH	0.4 x tBCK			ns
<b>PLL Slave Mode (PLL Reference Clock: MCKI pin) (Figure 8)</b>					
MCKI Input: Frequency	fCLK	11.2896		27.0	MHz
Pulse Width Low	fCLKL	0.4/fCLK			ns
Pulse Width High	fCLKH	0.4/fCLK			ns
MCKO Output:					
Frequency	fMCK		256 x fFCK		kHz
Duty Cycle except fs=29.4kHz, 32kHz	dMCK	40	50	60	%
fs=29.4kHz, 32kHz (Note 23)	dMCK		33		%
FCK: Frequency	fFCK	8		48	kHz
DSP Mode: Pulse width High	tFCKH	tBCK-60		1/fFCK-tBFCK	ns
Except DSP Mode: Duty Cycle	duty	45		55	%
BICK: Period	tBCK	1/64fFCK		1/16fFCK	ns
Pulse Width Low	tBCKL	0.4 x tBCK			ns
Pulse Width High	tBCKH	0.4 x tBCK			ns
<b>Audio Interface Timing</b>					
<b>DSP Mode: (Figure 9, Figure 10)</b>					
FCK "↑" to BICK "↑" (Note 24)	tFCKB	0.4 x tBCK			ns
FCK "↑" to BICK "↓" (Note 25)	tFCKB	0.4 x tBCK			ns
BICK "↑" to FCK "↑" (Note 24)	tBFCK	0.4 x tBCK			ns
BICK "↓" to FCK "↑" (Note 25)	tBFCK	0.4 x tBCK			ns
BICK "↑" to SDTO (BCKP = "0")	tBSD			80	ns
BICK "↓" to SDTO (BCKP = "1")	tBSD			80	ns
SDTI Hold Time	tSDH	50			ns
SDTI Setup Time	tSDS	50			ns
<b>Except DSP Mode: (Figure 12)</b>					
FCK Edge to BICK "↑" (Note 26)	tFCKB	50			ns
BICK "↑" to FCK Edge (Note 26)	tBFCK	50			ns
FCK to SDTO (MSB) (Except I <sup>2</sup> S mode)	tFSD			80	ns
BICK "↓" to SDTO	tBSD			80	ns
SDTI Hold Time	tSDH	50			ns
SDTI Setup Time	tSDS	50			ns

Parameter	Symbol	min	typ	Max	Units
<b>EXT Slave Mode (Figure 11)</b>					
MCKI Frequency: 256fs	fCLK	1.8816	2.048	12.288	MHz
512fs	fCLK	3.7632	4.096	13.312	MHz
1024fs	fCLK	7.5264	8.192	13.312	MHz
Pulse Width Low	tCLKL	0.4/fCLK			ns
Pulse Width High	tCLKH	0.4/fCLK			ns
FCK Frequency (MCKI = 256fs)	fFCK	7.35	8	48	kHz
(MCKI = 512fs)	fFCK	7.35	8	26	kHz
(MCKI = 1024fs)	fFCK	7.35	8	13	%
Duty Cycle	duty	45		55	%
BICK Period	tBCK	312.5			ns
BICK Pulse Width Low	tBCKL	130			ns
Pulse Width High	tBCKH	130			ns
<b>Audio Interface Timing (Figure 12)</b>					
FCK Edge to BICK “↑” (Note 26)	tFCKB	50			ns
BICK “↑” to FCK Edge (Note 26)	tBFCK	50			ns
FCK to SDTO (MSB) (Except I <sup>2</sup> S mode)	tFSD			80	ns
BICK “↓” to SDTO	tBSD			80	ns
SDTI Hold Time	tSDH	50			ns
SDTI Setup Time	tSDS	50			ns

Note 23. Duty Cycle = (the width of “L”) / (the period of clock) × 100

Note 24. MSBS, BCKP bits = “00” or “11”

Note 25. MSBS, BCKP bits = “01” or “10”

Note 26. BICK rising edge must not occur at the same time as FCK edge.

Parameter	Symbol	min	typ	max	Units
<b>Control Interface Timing:</b>					
CCLK Period	tCCK	200			ns
CCLK Pulse Width Low	tCCKL	80			ns
Pulse Width High	tCCKH	80			ns
CDTI Setup Time	tCDS	40			ns
CDTI Hold Time	tCDH	40			ns
CSN “H” Time	tCSW	150			ns
CSN “↓” to CCLK “↑”	tCSS	150			ns
CCLK “↑” to CSN “↑”	tCSH	50			ns
<b>Reset Timing</b>					
PDN Pulse Width (Note 27)	tPD	150			ns
PMADC “↑” to SDTO valid (Note 28)	tPDV		1059		1/fs

Note 27. The AK4631 can be reset by the PDN pin = “L”

Note 28. This is the count of FCK “↑” from the PMADC bit = “1”.

### ■ Timing Diagram

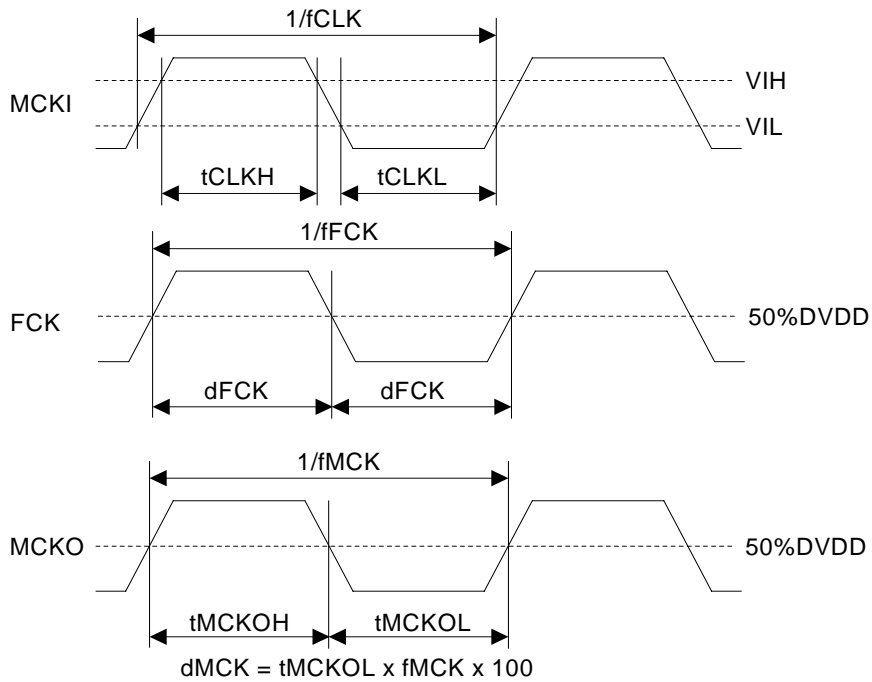

Figure 2. Clock Timing (PLL Master mode)

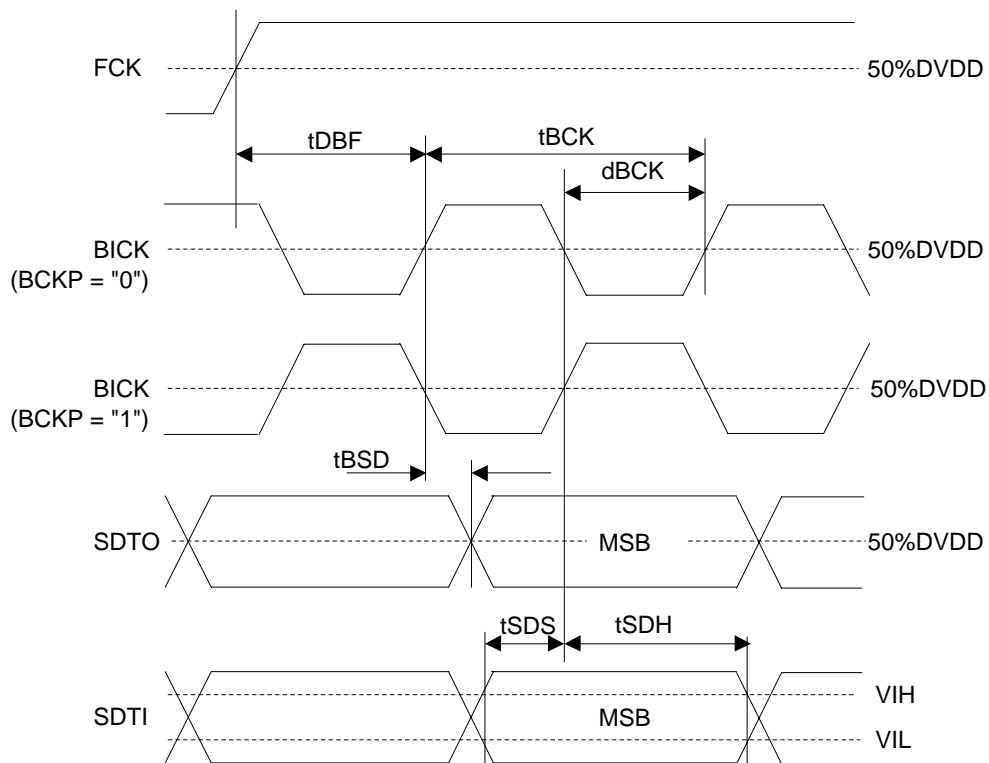

Figure 3. Audio Interface Timing (PLL Master mode & DSP mode: MSBS bit = "0")

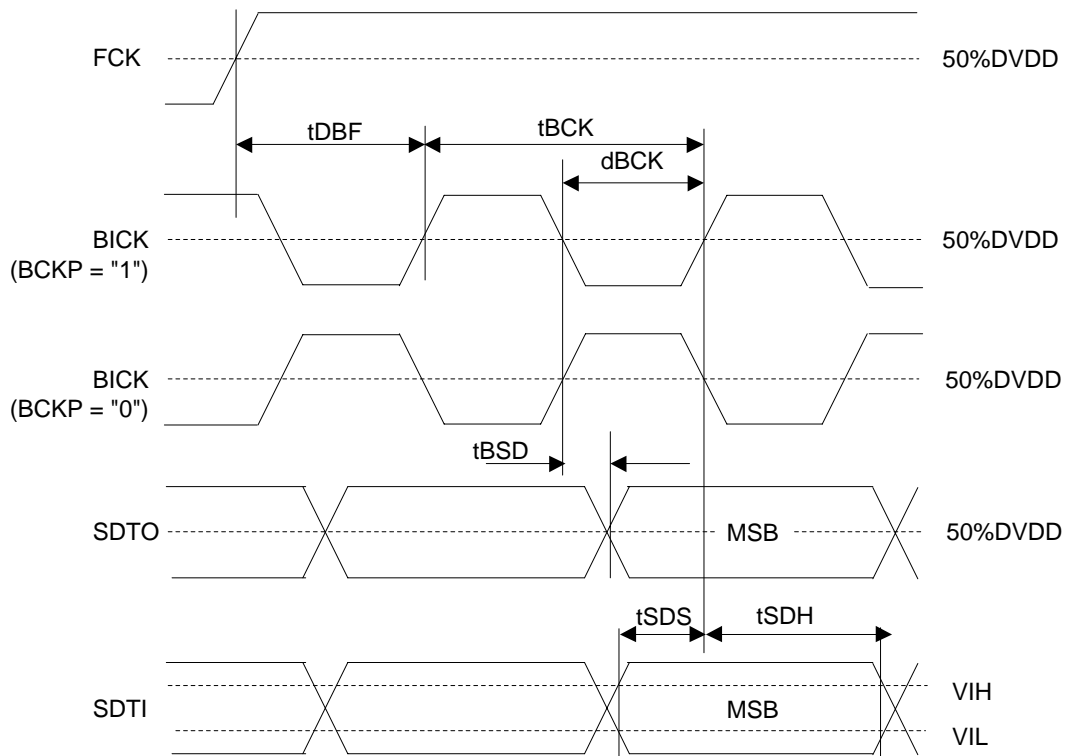

Figure 4. Audio Interface Timing (PLL Master mode & DSP mode: MSBS bit="1")

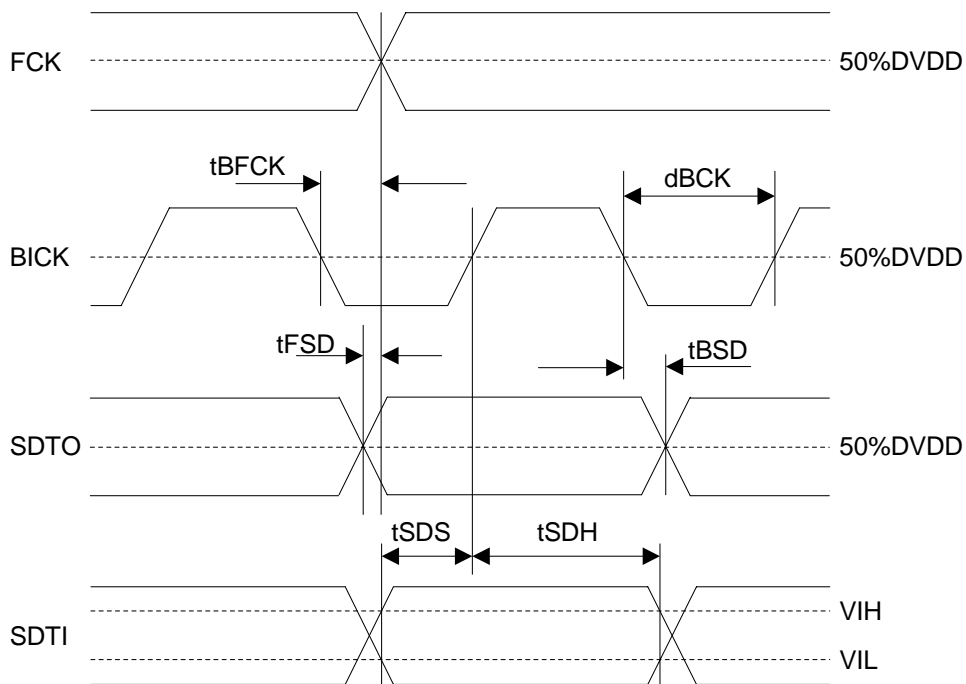

Figure 5. Audio Interface Timing (PLL Master mode & Except DSP mode)

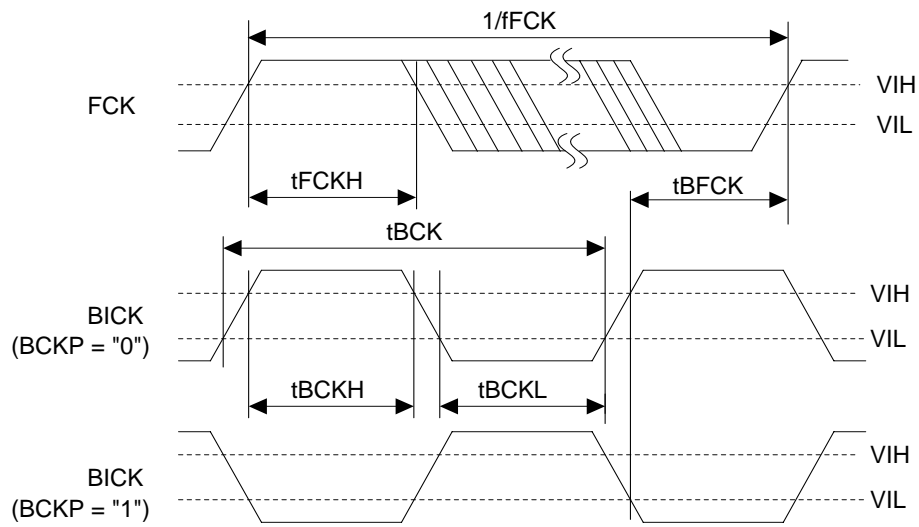

Figure 6. Clock Timing (PLL Slave mode; PLL Reference clock = FCK or BICK pin & DSP mode; MSBS bit = “0”)

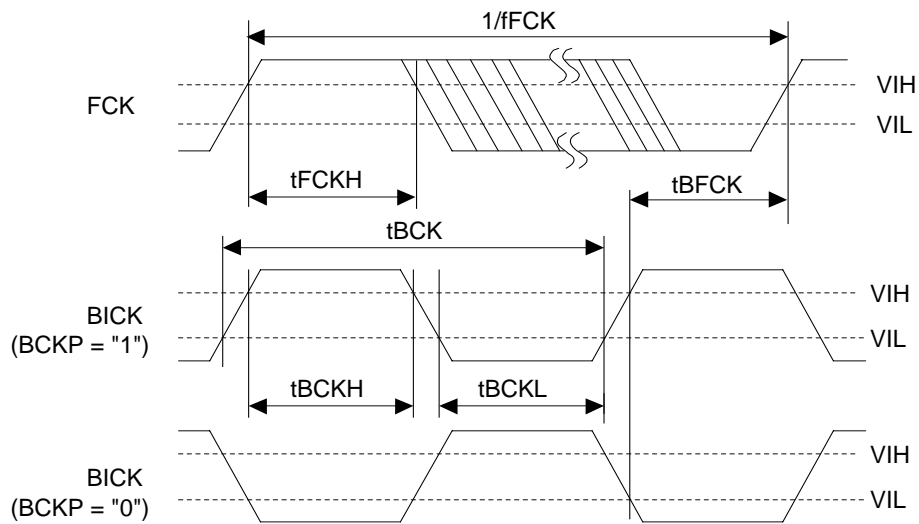

Figure 7. Clock Timing (PLL Slave mode; PLL Reference Clock = FCK or BICK pin & DSP mode; MSBS bit = “1”)

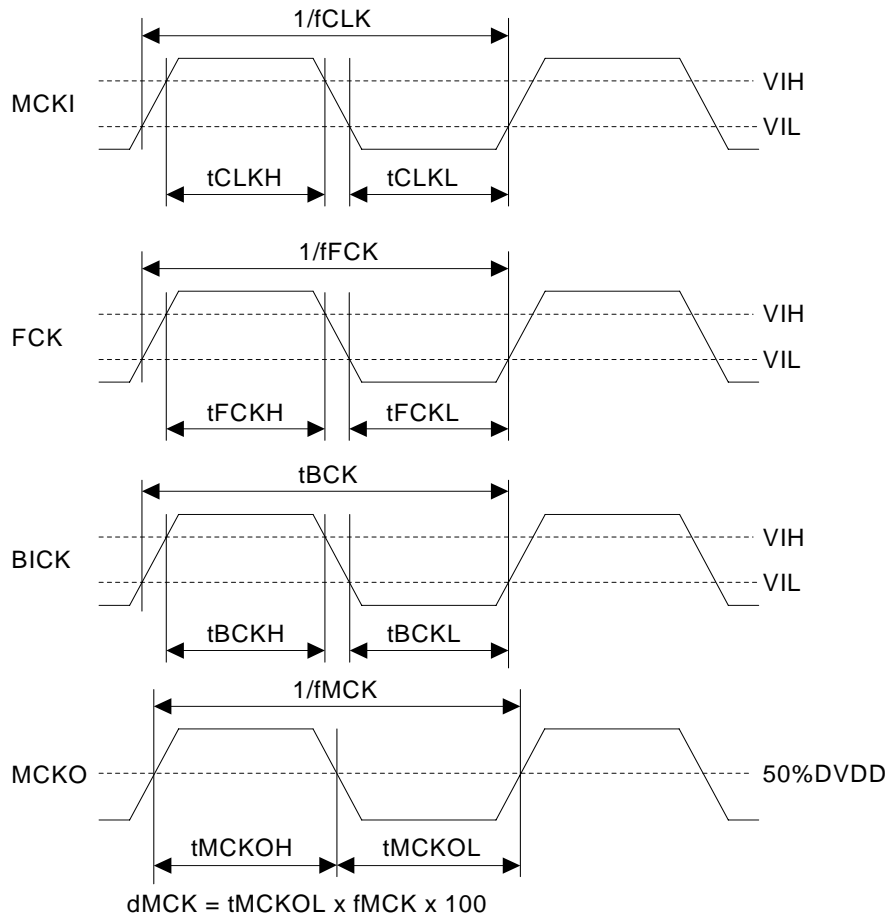

Figure 8. Clock Timing (PLL Slave mode; PLL Reference Clock = MCKI pin & Except DSP mode)

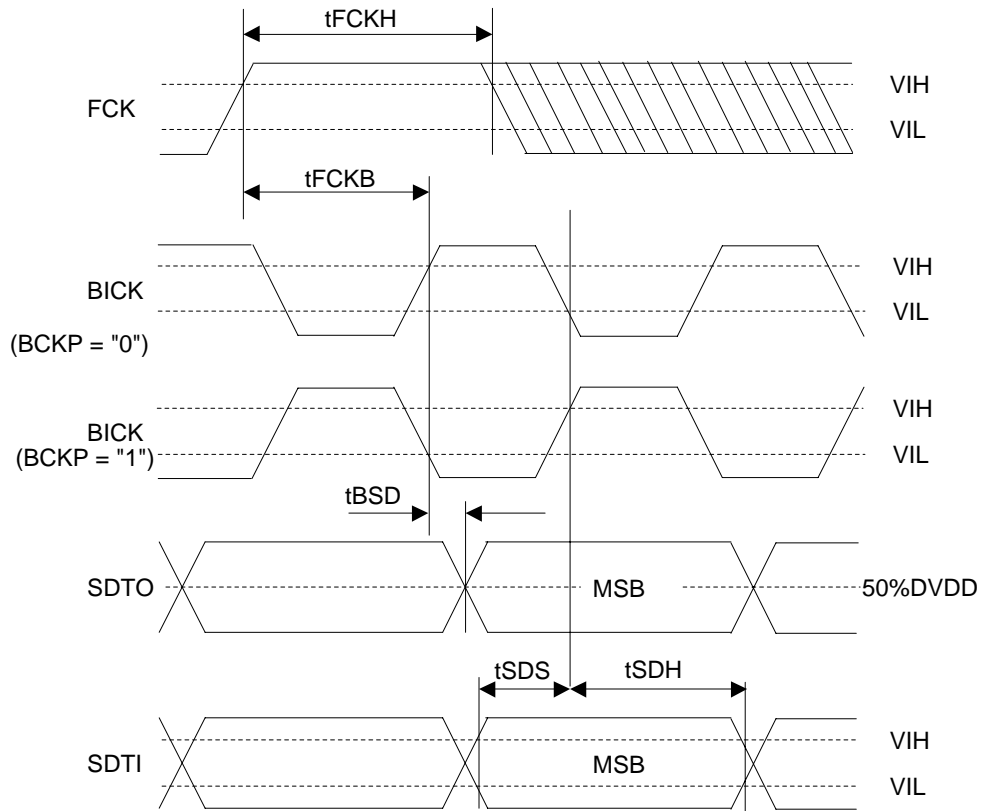

Figure 9. Audio Interface Timing (PLL Slave mode &amp; DSP mode; MSBS bit = "0")

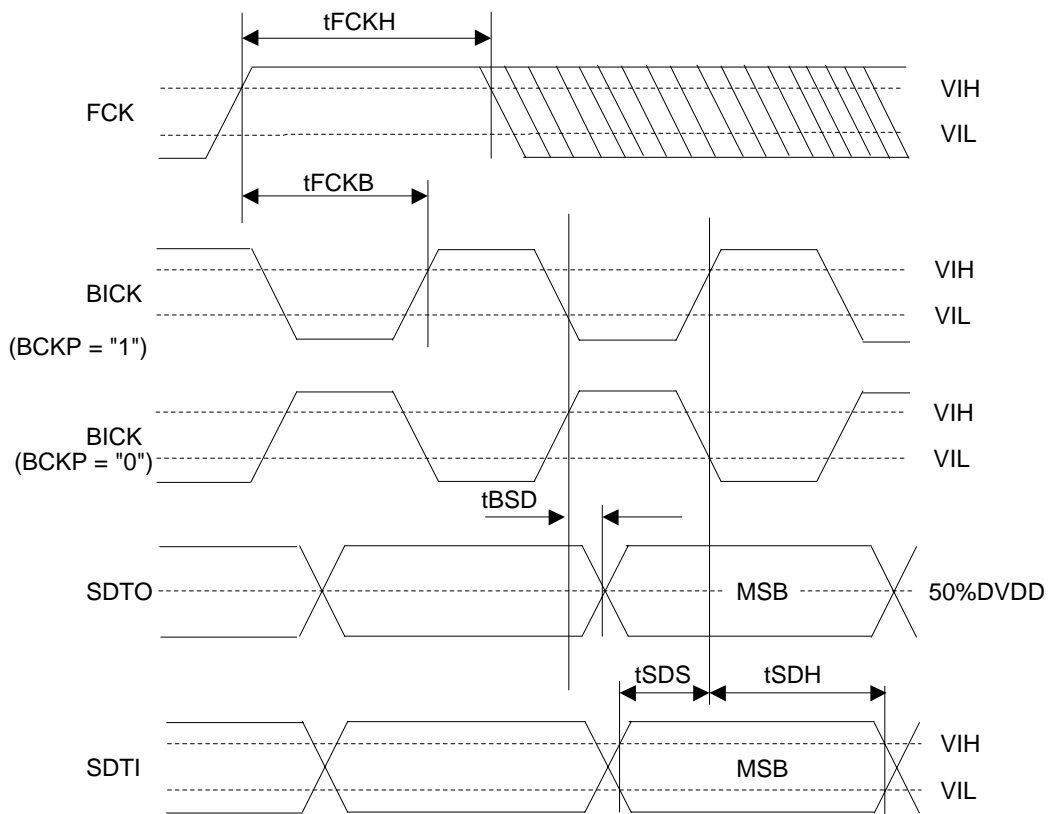

Figure 10. Audio Interface Timing (PLL Slave mode, DSP mode; MSBS bit = "1")

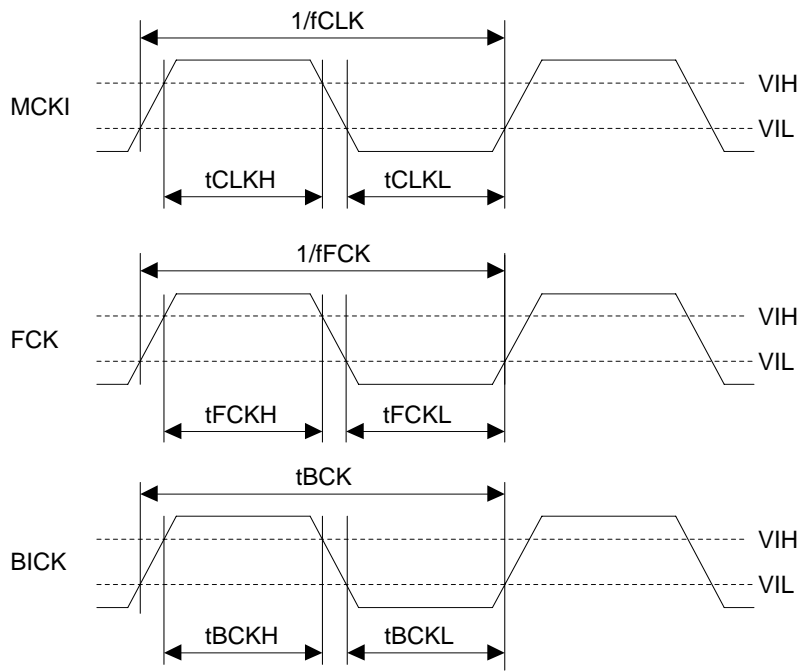

Figure 11. Clock Timing (EXT Slave mode)

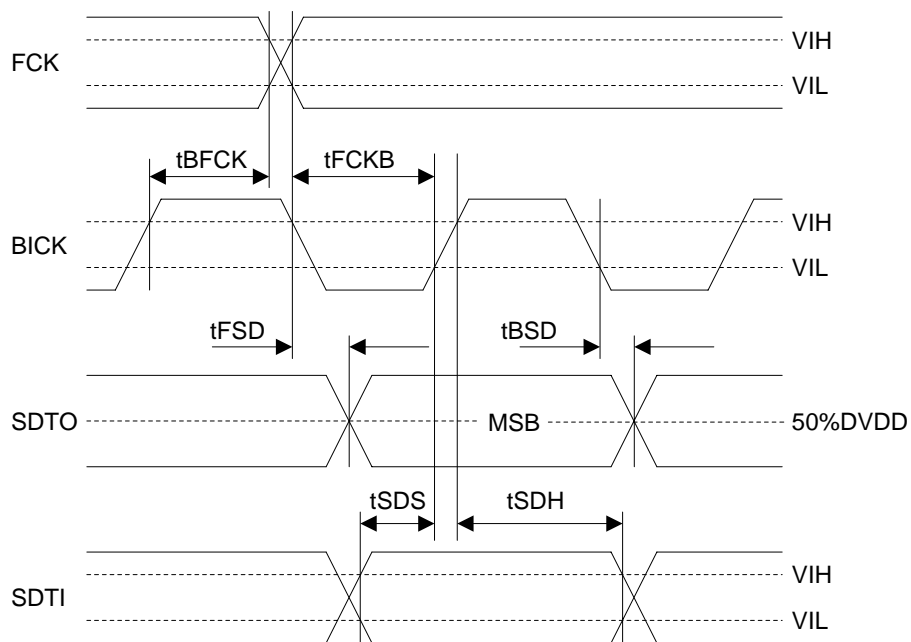

Figure 12. Audio Interface Timing (PLL, EXT Slave mode &amp; Except DSP mode)

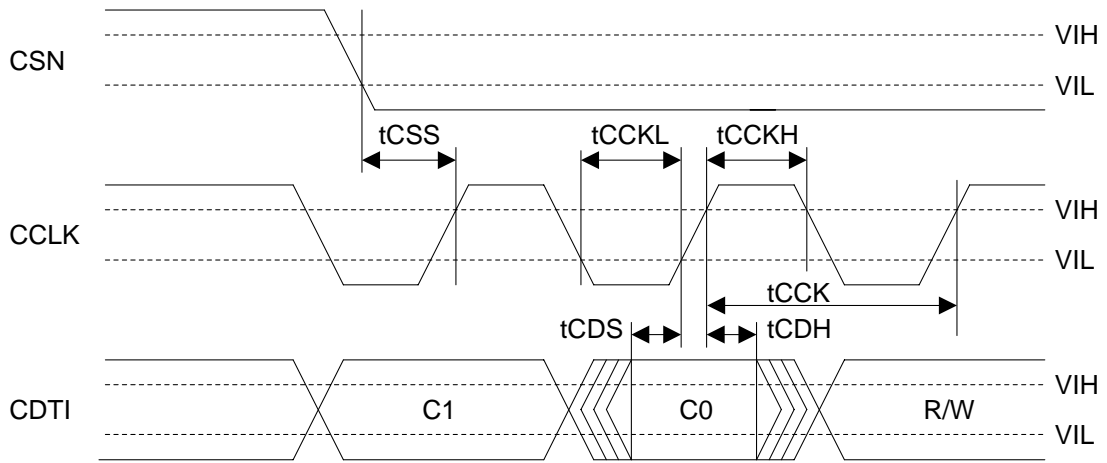

Figure 13. WRITE Command Input Timing

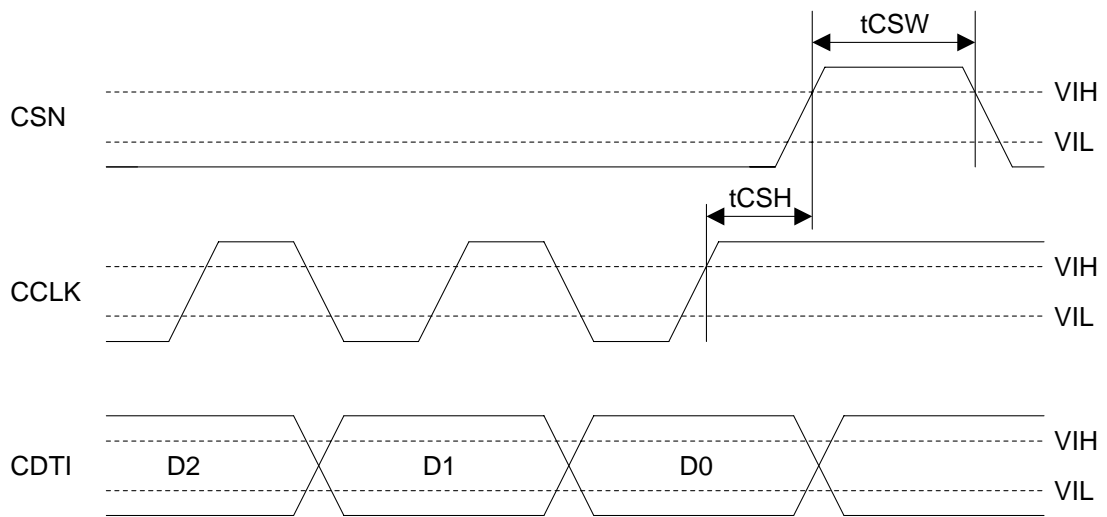

Figure 14. WRITE Data Input Timing

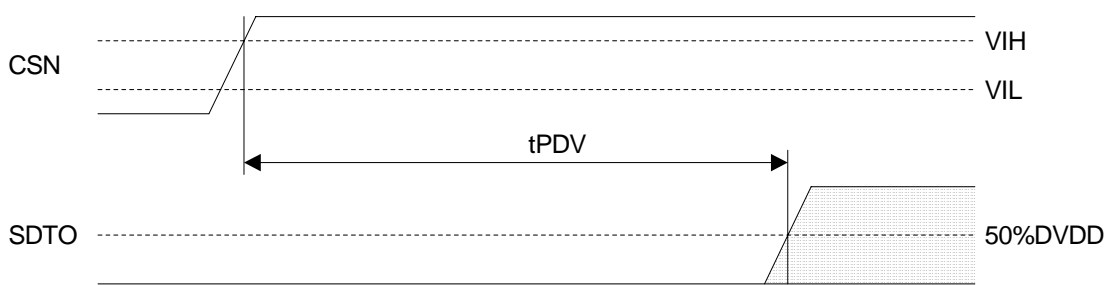

Figure 15. Power Down & Reset Timing 1

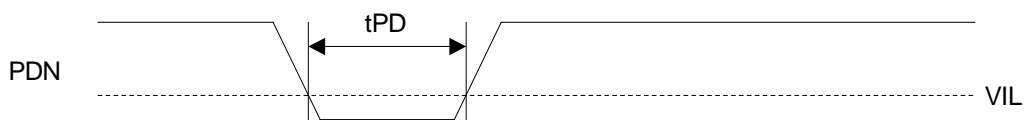

Figure 16. Power Down & Reset Timing 2

## OPERATION OVERVIEW

### ■ System Clock

There are the following four clock modes to interface with external devices. (Table 1 and Table 2)

Mode	PMPLL bit	M/S bit	PLL3-0 bit	MCKPD bit	Figure
PLL Master Mode	1	1	See Table 4	0	Figure 18
PLL Slave Mode 1 (PLL Reference Clock: MCKI pin)	1	0	See Table 4	0	Figure 19
PLL Slave Mode 2 (PLL Reference Clock: FCK or BICK pin)	1	0	See Table 4	1	Figure 20
EXT Slave Mode	0	0	X	0	Figure 21
Invalid state (Note 29)	0	1	X	X	-

Table 1. Clock Mode Setting (X: Don't care)

Note 29. If this mode is selected, the invalid clocks are output from the MCKO, FCK and BICK pins.

Mode	MCKO bit	MCKO pin	MCKI pin	BICK pin	FCK pin
PLL Master Mode	0	"L" Output	Master Clock Input for PLL (Note 30)	16fs/32fs/64fs Output	1fs Output
	1	256fs Output			
PLL Slave Mode 1 (PLL Reference Clock: MCKI pin)	0	"L" Output	Master Clock Input for PLL (Note 30)	16fs/32fs/64fs Input	1fs Input
	1	256fs Output			
PLL Slave Mode 2 (PLL Reference Clock: FCK or BICK pin)	0	"L" Output	GND	16fs/32fs/64fs Input	1fs Input
EXT Slave Mode	0	"L" Output	256fs/ 512fs/ 1024fs Input	≥ 32fs Input	1fs Input

Note 30. 11.2896MHz/12MHz/12.288MHz/13.5MHz/24MHz/27MHz

Table 2. Clock pins state in Clock Mode

[Pull-down resistor of MCKI pin]

When the master clock is input, MCKPD bit should be "0". When the MCKI pin is floating, it should be pulled-down by an internal 25kΩ resistor at MCKPD bit = "1" (default).

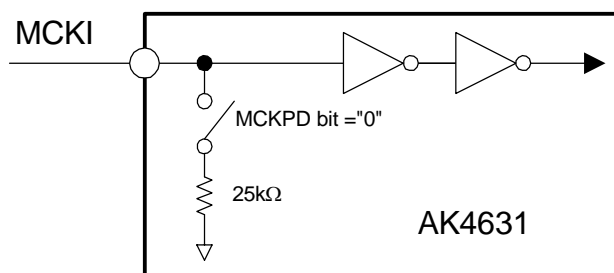

Figure 17. Pull-down resistor of MCKI pin

## ■ Master Mode/Slave Mode

The M/S bit selects either master or slave modes. M/S bit = “1” selects master mode and “0” selects slave mode. When the AK4631 is power-down mode (PDN pin = “L”) and exits reset state, the AK4631 is in slave mode. After exiting reset state, the AK4631 becomes master mode by changing M/S bit = “1”.

When the AK4631 is used in master mode, FCK and BICK pins are a floating state until M/S bit becomes “1”. FCK and BICK pins of the AK4631 should be pulled-down or pulled-up by a resistor about 100kΩ externally to avoid the floating state.

M/S bit	Mode
0	Slave Mode
1	Master Mode

(default)

Table 3. Select Master/Slave Mode

## ■ PLL Mode

When PMPLL bit is “1”, a fully integrated analog phase locked loop (PLL) generates a clock that is selected by the PLL3-0 and FS3-0 bits. The PLL lock time is shown in Table 4, whenever the AK4631 is supplied to a stable clocks after PLL is powered-up (PMPLL bit = “0” → “1”) or sampling frequency changes.

### 1) Setting of PLL Mode

Mode	PLL3 bit	PLL2 bit	PLL1 bit	PLL0 bit	PLL Reference Clock Input Pin	Input Frequency	R and C of VCOC pin		PLL Lock Time (max)
							R[Ω]	C[F]	
0	0	0	0	0	FCK pin	1fs	6.8k	220n	160ms
1	0	0	0	1	BICK pin	16fs	10k	4.7n	2ms
2	0	0	1	0	BICK pin	32fs	10k	4.7n	2ms
3	0	0	1	1	BICK pin	64fs	10k	4.7n	2ms
4	0	1	0	0	MCKI pin	11.2896MHz	10k	4.7n	40ms
5	0	1	0	1	MCKI pin	12.288MHz	10k	4.7n	40ms
6	0	1	1	0	MCKI pin	12MHz	10k	4.7n	40ms
7	0	1	1	1	MCKI pin	24MHz	10k	4.7n	40ms
12	1	1	0	0	MCKI pin	13.5MHz	10k	10n	40ms
13	1	1	0	1	MCKI pin	27MHz	10k	10n	40ms
Others	Others			N/A					

(default)

Table 4. Setting of PLL Mode (\*fs: Sampling Frequency)

### 2) Setting of sampling frequency in PLL Mode.

When PLL2 bit is “1” (PLL reference clock input is MCKI pin), the sampling frequency is selected by FS2-0 bits as defined in Table 5.

Mode	FS3 bit	FS2 bit	FS1 bit	FS0 bit	Sampling Frequency
0	0	0	0	0	8kHz
1	0	0	0	1	12kHz
2	0	0	1	0	16kHz
3	0	0	1	1	24kHz
4	0	1	0	0	7.35kHz
5	0	1	0	1	11.025kHz
6	0	1	1	0	14.7kHz
7	0	1	1	1	22.05kHz
10	1	0	1	0	32kHz
11	1	0	1	1	48kHz
14	1	1	1	0	29.4kHz
15	1	1	1	1	44.1kHz
Others	Others				N/A

(default)

Table 5. Setting of Sampling Frequency at PLL2 bit = “1” and PMPLL bit = “1”

When PLL2 bit is “0” (PLL reference clock input is FCK or BICK pin), the sampling frequency is selected by FS3, FS1-0 bits. (Table 6)

Mode	FS3 bit	FS2 bit	FS1 bit	FS0 bit	Sampling Frequency Range
0	0	Don't care	0	0	$7.35\text{kHz} \leq f_s \leq 8\text{kHz}$ (default)
1	0	Don't care	0	1	$8\text{kHz} < f_s \leq 12\text{kHz}$
2	0	Don't care	1	0	$12\text{kHz} < f_s \leq 16\text{kHz}$
3	0	Don't care	1	1	$16\text{kHz} < f_s \leq 24\text{kHz}$
6	1	Don't care	1	0	$24\text{kHz} < f_s \leq 32\text{kHz}$
7	1	Don't care	1	1	$32\text{kHz} < f_s \leq 48\text{kHz}$
Others	Others				N/A

Table 6. Setting of Sampling Frequency at PLL2 bit = “0” and PMPLL bit = “1”

(Note) The sampling frequency is  $7.35\text{kHz} \leq f_s \leq 26\text{kHz}$  when FCK is referenced (PLL3-0 bits = “0000”)

## ■ PLL Unlock State

1) PLL Master Mode (PMPLL bit = “1”, M/S bit = “1”)

In this mode, irregular frequency clocks are output from FCK, BICK and MCKO pins after PMPLL bit = “0” → “1” or sampling frequency is changed. After that PLL is unlocked, BICK and FCK pins output “L” for a moment, and invalid frequency clock is output from the MCKO pin at MCKO bit = “1”. If MCKO bit is “0”, the MCKO pin is output to “L”. (Table 7)

After the PLL is locked, a first period of FCK and BICK may be invalid clock, but these clocks return to normal state after 1/fs.

PLL State	MCKO pin		BICK pin	FCK pin
	MCKO bit = “0”	MCKO bit = “1”		
After that PMPLL bit “0” → “1”	“L” Output	Invalid	Invalid	Invalid
PLL Unlock	“L” Output	Invalid	“L” Output	“L” Output
PLL Lock	“L” Output	256fs Output	See Table 9	1fs Output

Table 7. Clock Operation at PLL Master Mode (PMPLL bit = “1”, M/S bit = “1”)

2) PLL Slave Mode (PMPLL bit = “1”, M/S bit = “0”)

In this mode, an invalid clock is output from the MCKO pin after PMPLL bit = “0” → “1” or sampling frequency is changed. After that, 256fs is output from the MCKO pin when PLL is locked. ADC and DAC output invalid data when the PLL is unlocked. For DAC, the output signal should be muted by writing “0” to DACA and DACM bits in Addr=02H.

PLL State	MCKO pin	
	MCKO bit = “0”	MCKO bit = “1”
After that PMPLL bit “0” → “1”	“L” Output	Invalid
PLL Unlock	“L” Output	Invalid
PLL Lock	“L” Output	256fs Output

Table 8. Clock Operation at PLL Slave Mode (PMPLL bit = “1”, M/S bit = “0”)

### ■ PLL Master Mode (PMPLL bit = “1”, M/S bit = “1”)

When an external clock (11.2896MHz, 12MHz, 12.288MHz, 13.5MHz, 24MHz or 27MHz) is input to MCKI pin, the MCKO, BICK and FCK clocks are generated by an internal PLL circuit. The MCKO output frequency is fixed to 256fs, the output is enabled by MCKO bit. The BICK is selected among 16fs, 32fs or 64fs, by BCKO1-0 bits. (Table 9)

When BICK output frequency is 16fs, the audio interface format supports only Mode 0 (DSP Mode).

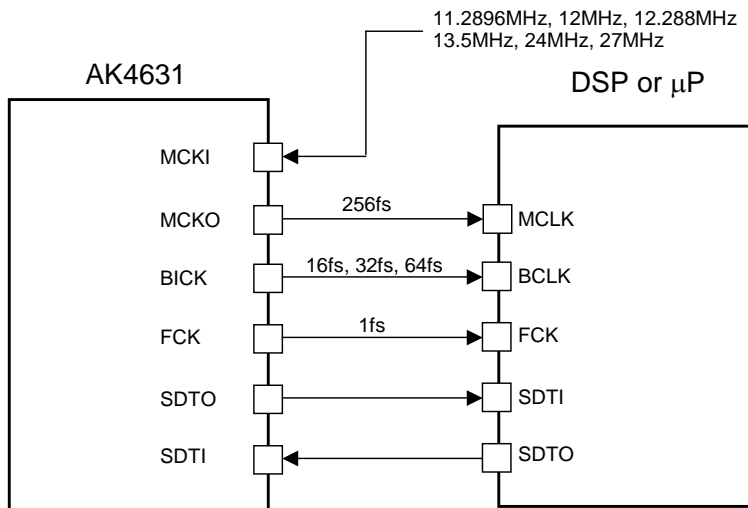

Figure 18. PLL Master Mode

Mode	BCKO1	BCKO0	BICK Output Frequency
0	0	0	16fs
1	0	1	32fs
2	1	0	64fs
3	1	1	N/A

(default)

Table 9. BICK Output Frequency at Master Mode

### ■ PLL Slave Mode (PMPLL bit = “1”, M/S bit = “0”)

A reference clock of PLL is selected among the input clocks to the MCKI, BICK or FCK pin. The required clock to the AK4631 is generated by an internal PLL circuit. Input frequency is selected by PLL3-0 bits. When BICK input frequency is 16fs, the audio interface format only supports Mode 0 (DSP Mode).

#### a) PLL reference clock: BICK or FCK pin

In case of using BICK for PLL reference clock, the sampling frequency corresponds to 7.35kHz to 48kHz by changing FS3-0 bits. In case of using FCK, the sampling frequency corresponds to 7.35kHz to 26kHz. (Table 6)

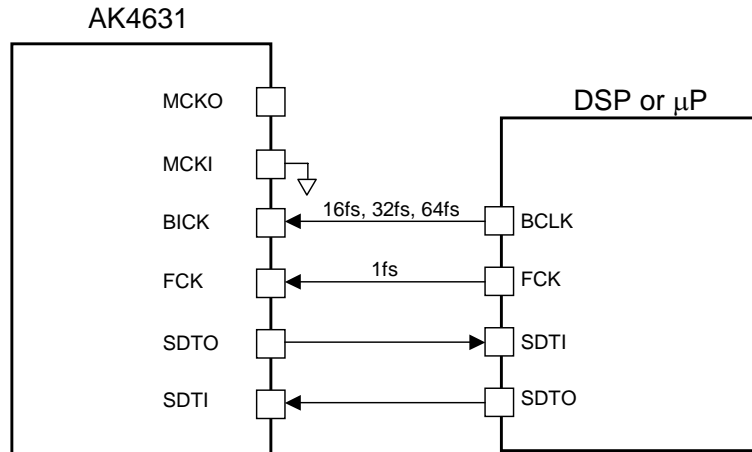

Figure 19. PLL Slave Mode 1 (PLL Reference Clock: FCK or BICK pin)

#### b) PLL reference clock: MCKI pin

BICK and FCK inputs must be synchronized with MCKO output. The phase between MCKO and FCK dose not matter. Sampling frequency can be selected by FS3-0 bits. (See Table 5)

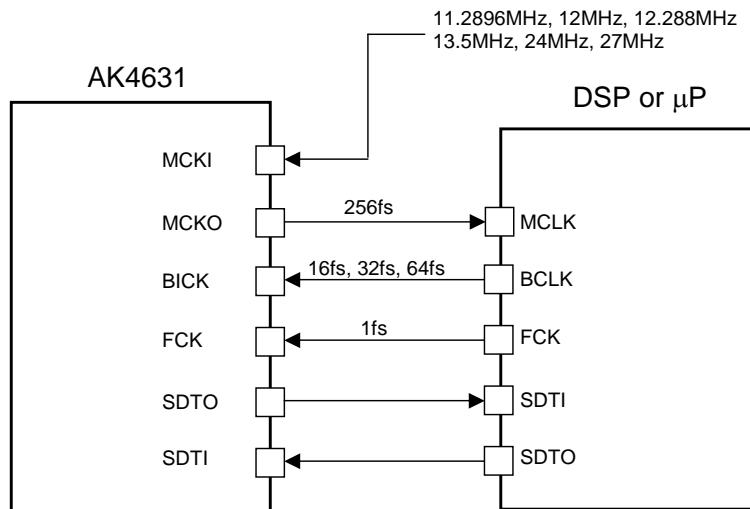

Figure 20. PLL Slave Mode 2 (PLL Reference Clock: MCKI pin)

The external clocks (MCKI, BICK and FCK) should always be present whenever the ADC or DAC is in operation (PMADC bit = “1” or PMDAC bit = “1”). If these clocks are not provided, the AK4631 may draw excess current and it is not possible to operate properly because utilizes dynamic refreshed logic internally. If the external clocks are not present, the ADC and DAC should be in the power-down mode (PMADC bit = PMDAC bit = “0”).

### ■ EXT Slave Mode (PMPLL bit = “0”, M/S bit = “0”)

When PMPLL bit is “0”, the AK4631 becomes EXT mode. Master clock is input from the MCKI pin, the internal PLL circuit is not operated. This mode is compatible with I/F of the normal audio CODEC. The clocks required to operate are MCKI (256fs, 512fs or 1024fs), FCK (fs) and BICK (32fs~). The master clock (MCKI) should be synchronized with FCK. The phase between these clocks does not matter. The input frequency of MCKI is selected by FS3-0 bits. (Table 10)

Mode	FS3-2 bits	FS1 bit	FS0 bit	MCKI Input Frequency	Sampling Frequency Range	(default)
0	Don't care	0	0	256fs	$7.35\text{kHz} \leq fs \leq 48\text{kHz}$	
1	Don't care	0	1	1024fs	$7.35\text{kHz} < fs \leq 13\text{kHz}$	
2	Don't care	1	0	256fs	$7.35\text{kHz} < fs \leq 48\text{kHz}$	
3	Don't care	1	1	512fs	$7.35\text{kHz} < fs \leq 26\text{kHz}$	

Table 10. MCKI Frequency at EXT Slave Mode (PMPLL bit = “0”, M/S bit = “0”)

### External Slave Mode does not support Mode 0 (DSP Mode) of Audio Interface Format.

The S/N of the DAC at low sampling frequencies is worse than at high sampling frequencies due to out-of-band noise. When the out-of-band noise can be improved by using higher frequency of the master clock. The S/N of the DAC output through AOUT amp at fs=8kHz is shown in Table 11.

MCKI	S/N (fs=8kHz, 20kHzLPF + A-weight)
256fs	83dB
512fs	93dB
1024fs	93dB

Table 11. Relationship between MCKI and S/N of AOUT

The external clocks (MCKI, BICK and FCK) should always be present whenever the ADC or DAC is in operation (PMADC bit = “1” or PMDAC bit = “1”). If these clocks are not provided, the AK4631 may draw excess current and it is not possible to operate properly because utilizes dynamic refreshed logic internally. If the external clocks are not present, the ADC and DAC should be in the power-down mode (PMADC bit = PMDAC bit = “0”).

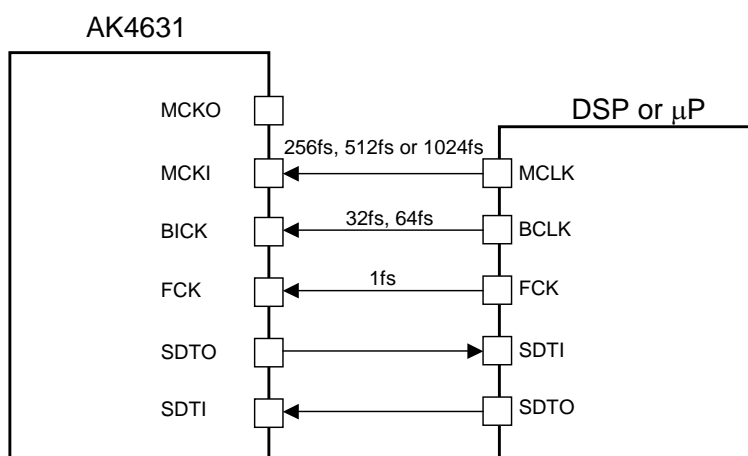

Figure 21. EXT Slave Mode

## ■ Audio Interface Format

Four types of data formats are available and are selected by setting the DIF1-0 bits. (Table 12) In all modes, the serial data is MSB first, 2's complement format. Audio interface formats can be used in both master and slave modes. FCK and BICK are output from the AK4631 in master mode, but must be input to AK4631 in slave mode.

In Mode 1-3, the SDTO is clocked out on the falling edge of BICK and the SDTI is latched on the rising edge.

Mode	DIF1	DIF0	SDTO (ADC)	SDTI (DAC)	BICK	Figure
0	0	0	DSP Mode	DSP Mode	$\geq 16fs$	See Table 13
1	0	1	MSB justified	MSB justified	$\geq 32fs$	Figure 26
2	1	0	MSB justified	MSB justified	$\geq 32fs$	Figure 27
3	1	1	I <sup>2</sup> S compatible	I <sup>2</sup> S compatible	$\geq 32fs$	Figure 28

(default)

Table 12. Audio Interface Format

In Mode0 (DSP mode), the audio I/F timing is changed by BCKP and MSBS bits.

When BCKP bit is "0", SDTO data is output by rising edge of BICK, SDTI data is latched by falling edge of BICK. When BCKP bit is "1", SDTO data is output by falling edge of BICK, SDTI data is latched by rising edge of BICK.

MSB data position of SDTO and SDTI can be shifted by MSBS bit. The shifted period is a half of BICK.

MSBS bit	BCKP bit	Audio Interface Format
0	0	Figure 22
0	1	Figure 23
1	0	Figure 24
1	1	Figure 25

(default)

Table 13. Audio Interface Format in Mode 0

If 16-bit data that ADC outputs is converted to 8-bit data by removing LSB 8-bit, "-1" at 16bit data is converted to "-1" at 8-bit data. And when the DAC playbacks this 8-bit data, "-1" at 8-bit data will be converted to "-256" at 16-bit data and this is a large offset. This offset can be removed by adding the offset of "128" to 16-bit data before converting to 8-bit data.

## ■ System Reset

Upon power-up, reset the AK4631 by bringing the PDN pin = "L". This ensures that all internal registers reset to their initial values.

The ADC enters an initialization cycle that starts when the PMADC bit is changed from "0" to "1". The initialization cycle time is 1059/fs, or 133ms@fs=8kHz. During the initialization cycle, the ADC digital data outputs of both channels are forced to a 2's complement, "0". The ADC output reflects the analog input signal after the initialization cycle is complete. The DAC does not require an initialization cycle.

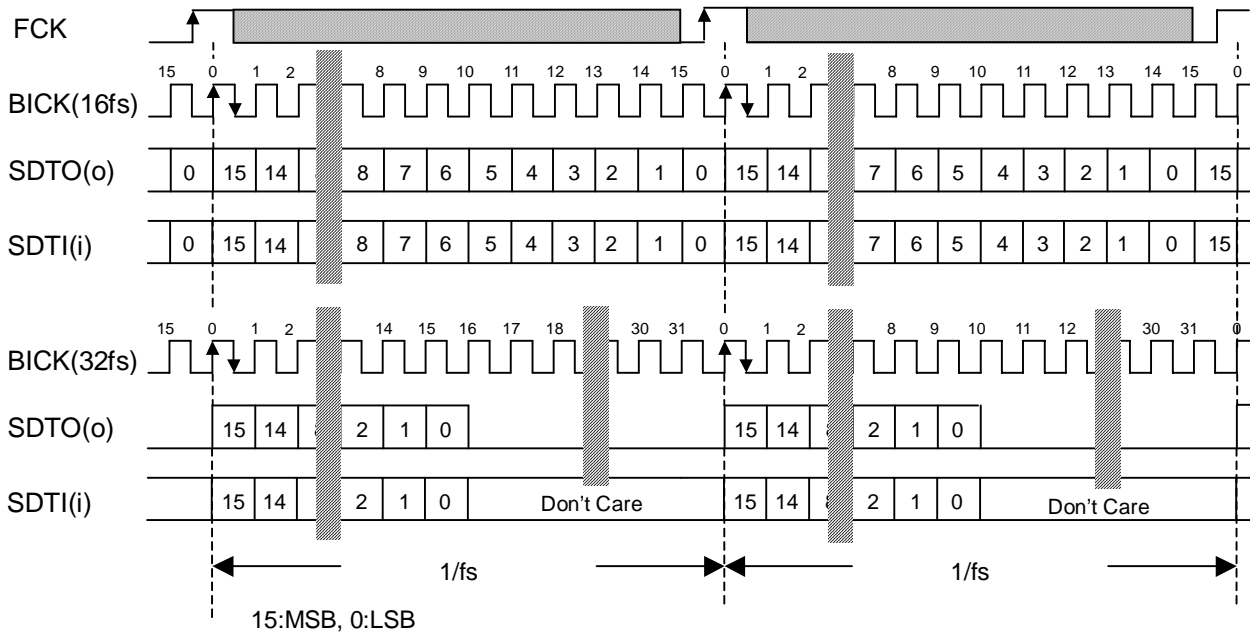

Figure 22. Mode 0 Timing (BCKP = "0", MSBS = "0")

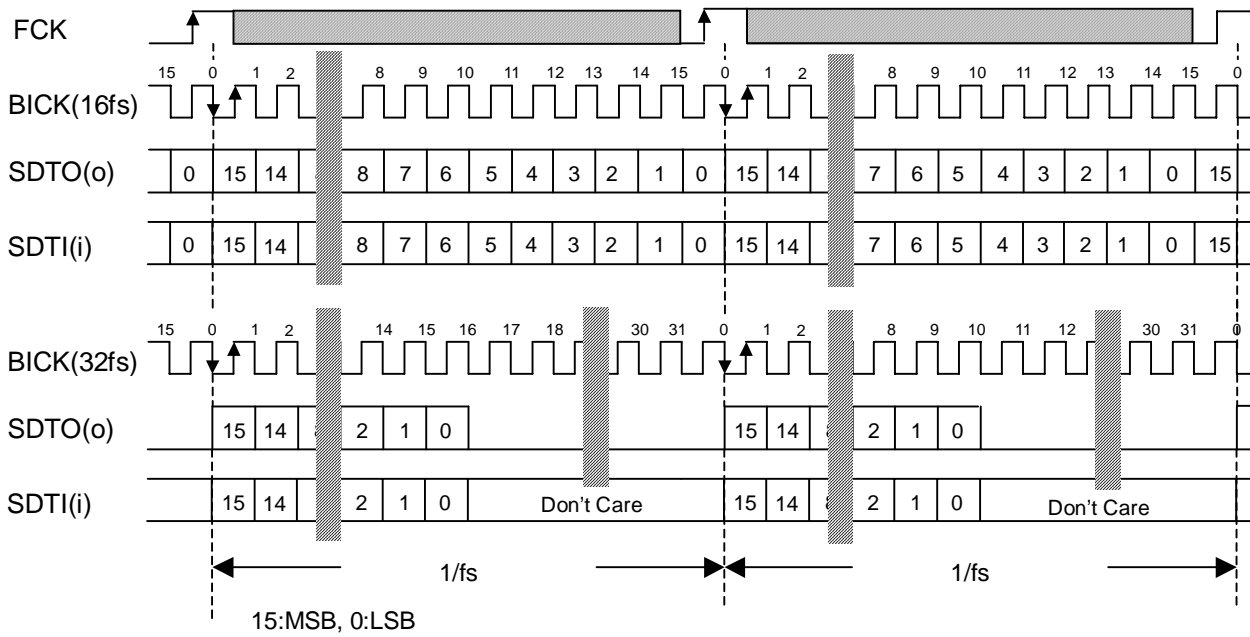

Figure 23. Mode 0 Timing (BCKP = "1", MSBS = "0")

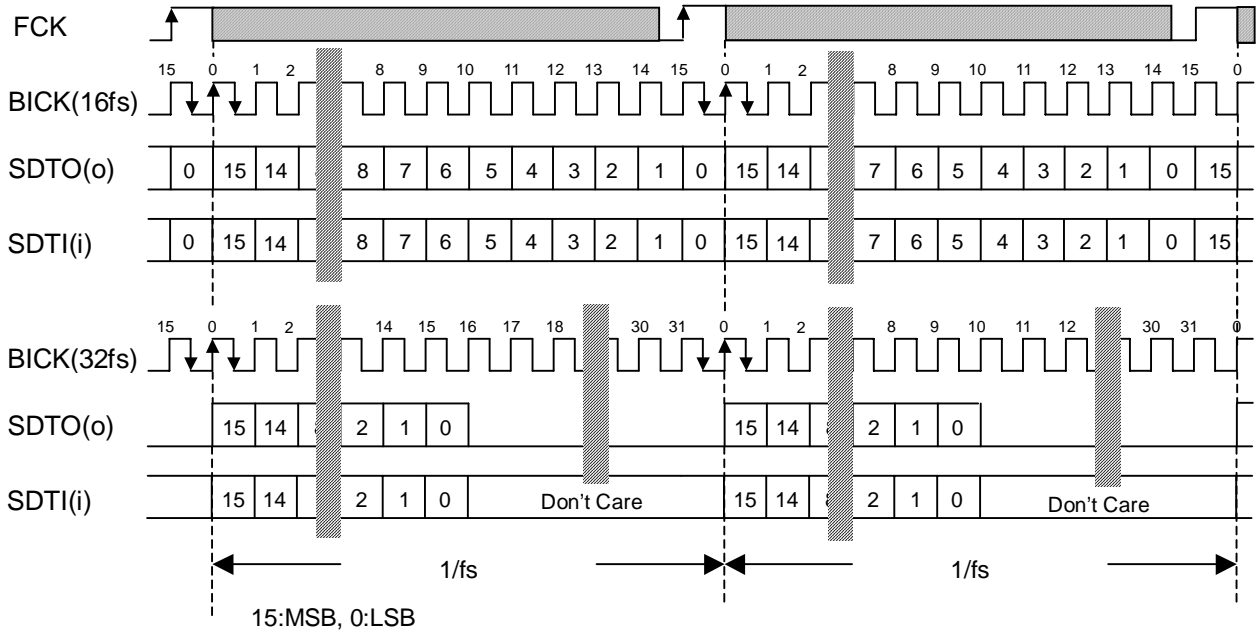

Figure 24. Mode 0 Timing (BCKP = "0", MSBS = "1")

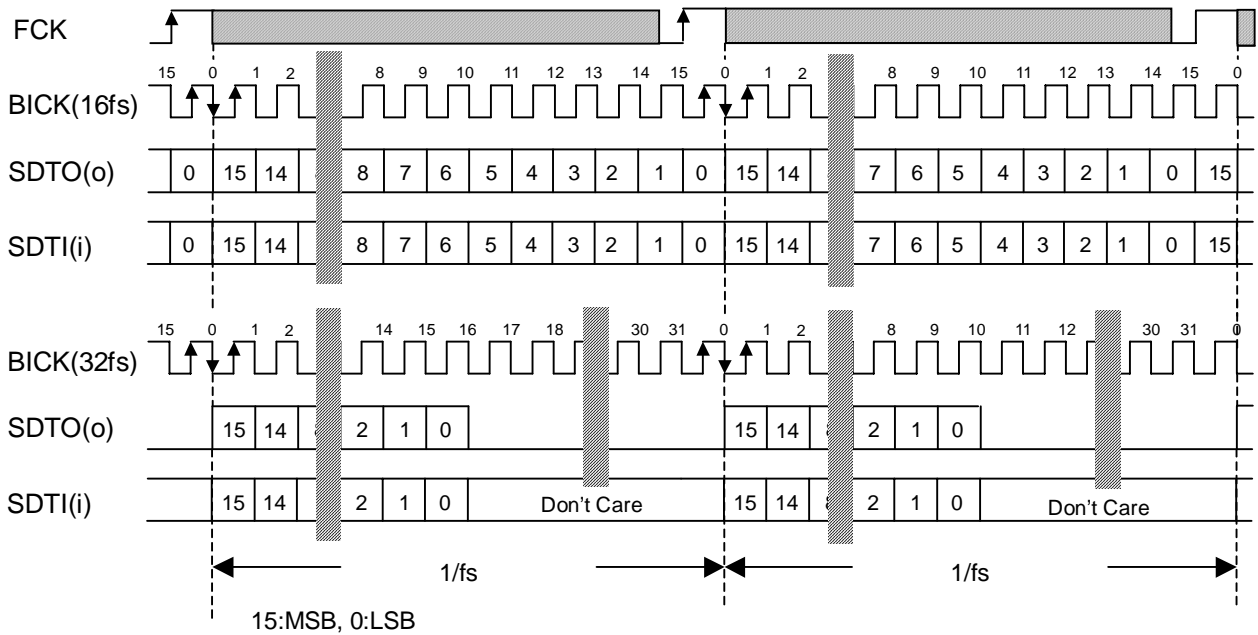

Figure 25. Mode 0 Timing (BCKP = "1", MSBS = "1")

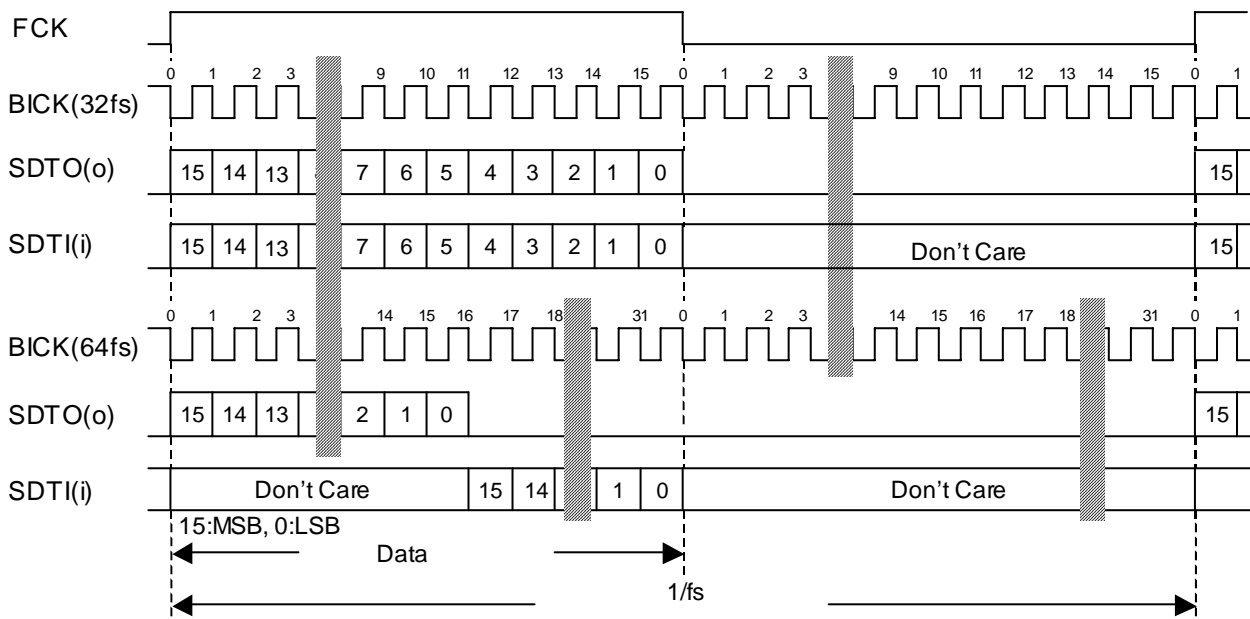

Figure 26. Mode 1 Timing

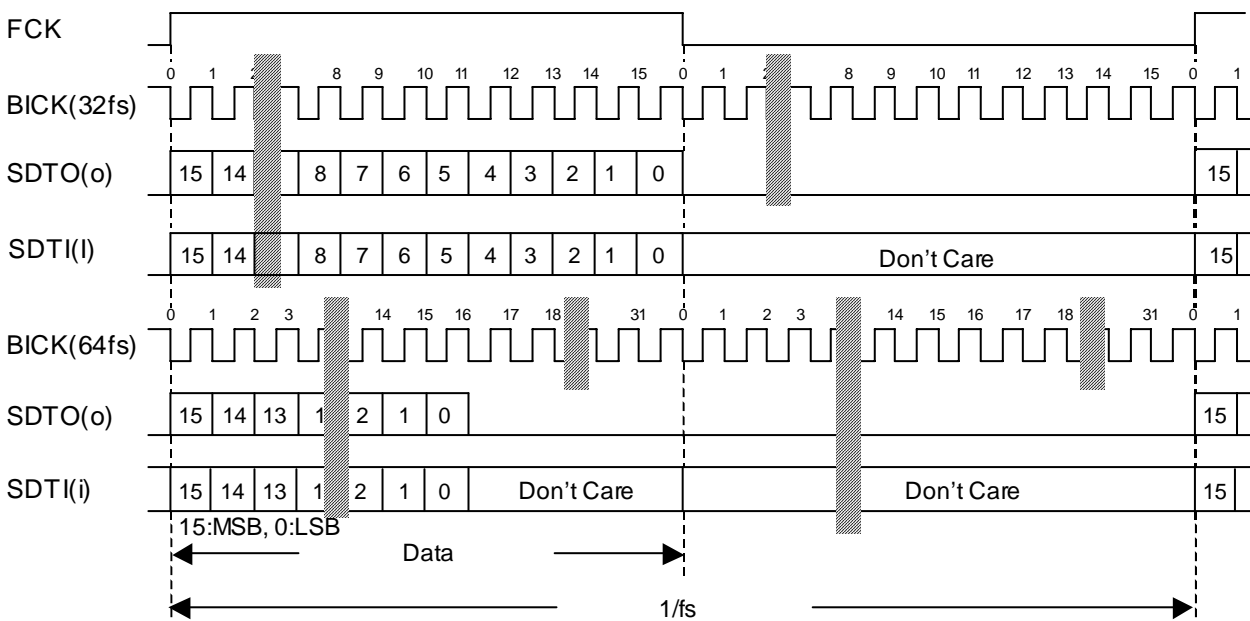

Figure 27. Mode 2 Timing

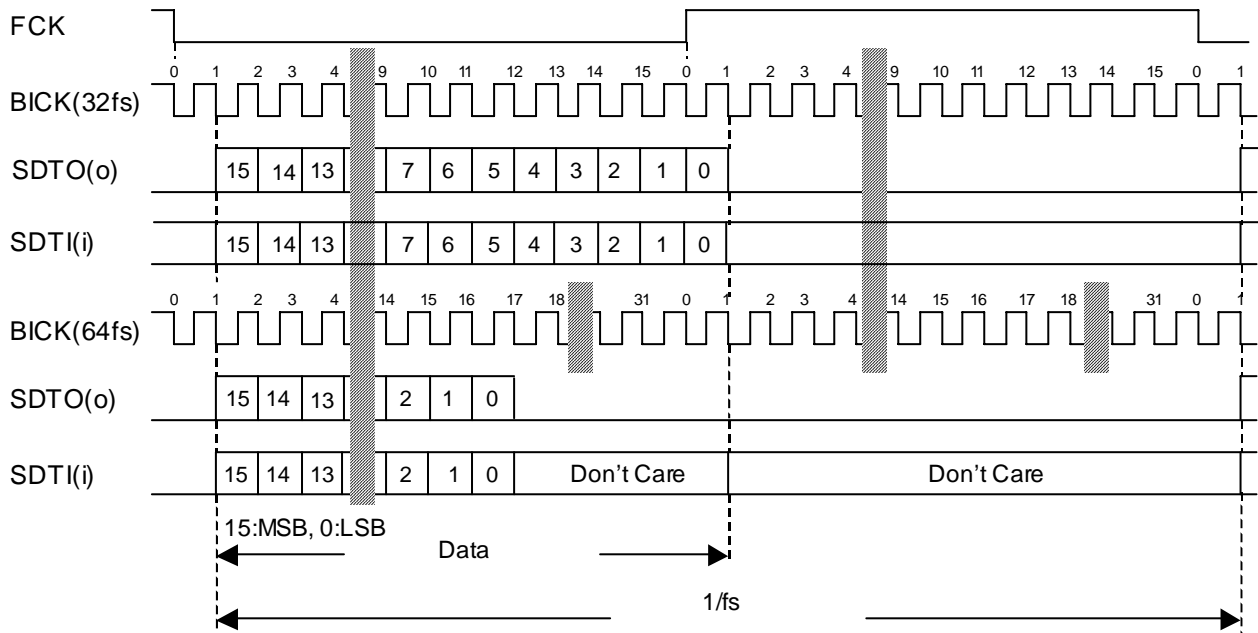

Figure 28. Mode 3 Timing

### ■ Digital High Pass Filter

The ADC has a digital high pass filter for DC offset cancellation. The cut-off frequency of the HPF is 1.25Hz (@fs=8kHz) and scales with sampling rate (fs).

### ■ MIC Gain Amplifier

The AK4631 has a Gain Amplifier for Microphone input. This gain is 0dB, +20dB, +26dB or +32dB, selected by the MGAIN1-0 bit. The typical input impedance is 30kΩ.

MGAIN1 bit	MGAIN0 bit	Input Gain
0	0	0dB
0	1	+20dB
1	0	+26dB
1	1	+32dB

(default)

Table 14. Input Gain

### ■ MIC Power

The MPI pin supplies power for the Microphone. This output voltage is typically 0.75 x AVDD and the load resistance is minimum 2kΩ. No capacitor must not be connected directly to the MPI pin. (Figure 29)

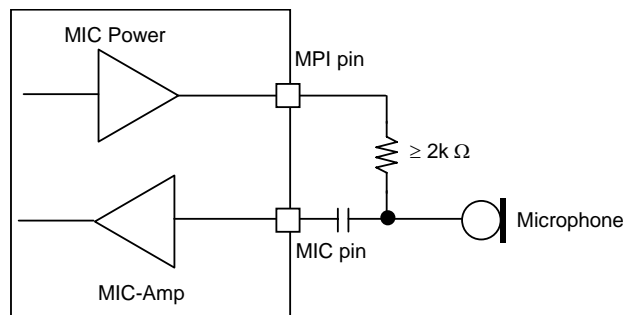

Figure 29. MIC Block Circuit

## ■ Manual Mode

The AK4631 becomes a manual mode at ALC1 bit = "0". This mode is used in the case shown below.

1. After exiting reset state, set up the registers for the ALC1 operation (ZTM1-0, LMTH and etc)
2. When the registers for the ALC1 operation (Limiter period, Recovery period and etc) are changed.  
For example; When the change of the sampling frequency.
3. When IPGA is used as a manual volume.

When IPGA6-0 bits are written at manual mode, the counter for zero cross time out is reset and restart. The IPGA6-0 bits value are reflected to IPGA at zero cross or zero cross time out. The time of zero cross time out is set by ZTM1-0 bits.

When writing to IPGA6-0 bits continually, the control register should be written by an interval of more than zero crossing timeout.

## ■ MIC-ALC Operation

The ALC (Automatic Level Control) of MIC input is done by ALC1 block when ALC1 bit is "1".

### [1] ALC1 Limiter Operation

When the ALC1 limiter is enabled, and IPGA output exceeds the ALC1 limiter detection level (LMTH), the IPGA value is attenuated by the amount defined in the ALC1 limiter ATT step (LMAT1-0 bits) automatically.

When the ZELM bit = "1", the timeout period is set by the LTM1-0 bits. The operation for attenuation is done continuously until the input signal level becomes LMTH or less. If the ALC1 bit does not change into "0" after completing the attenuation, the attenuation operation repeats while the input signal level equals or exceeds LMTH.

When the ZELM bit = "0", the timeout period is set by the ZTM1-0 bits. This enables the zero-crossing attenuation function so that the IPGA value is attenuated at the zero-detect points of the waveform.

### [2] ALC1 Recovery Operation

The ALC1 recovery refers to the amount of time that the AK4631 will allow a signal to exceed a predetermined limiting value prior to enabling the limiting function. The ALC1 recovery operation uses the WTM1-0 bits to define the wait period used after completing an ALC1 limiter operation. If the input signal does not exceed the "ALC1 Recovery Waiting Counter Reset Level", the ALC1 recovery operation starts. The IPGA value increases automatically during this operation up to the reference level (REF6-0 bits). The ALC1 recovery operation is done at a period set by the WTM1-0 bits. Zero crossing is detected during WTM1-0 period, the ALC1 recovery operation waits WTM1-0 period and the next recovery operation starts.

During the ALC1 recovery operation, when input signal level exceeds the ALC1 limiter detection level (LMTH), the ALC1 recovery operation changes immediately into an ALC1 limiter operation.

In the case of "(Recovery waiting counter reset level) ≤ IPGA Output Level < Limiter detection level" during the ALC1 recovery operation, the wait timer for the ALC1 recovery operation is reset. Therefore, in the case of "(Recovery waiting counter reset level) > IPGA Output Level", the wait timer for the ALC1 recovery operation starts.

The ALC1 operation corresponds to the impulse noise. When the impulse noise is input, the ALC1 recovery operation becomes faster than a normal recovery operation.

## [3] Example of ALC1 Operation

Table 15 shows the example of the ALC1 setting. In this case, ALC1 operation starts from 0dB.

Register Name	Comment	fs=8kHz		fs=16kHz	
		Data	Operation	Data	Operation
LMTH	Limiter detection Level	1	-4dBFS	1	-4dBFS
LTM1-0	Limiter operation period at ZELM = 1	00	Don't use	00	Don't use
ZELM	Limiter zero crossing detection	0	Enable	0	Enable
ZTM1-0	Zero crossing timeout period	00	16ms	01	16ms
WTM1-0	Recovery waiting period *WTM1-0 bits should be the same data as ZTM1-0 bits	00	16ms	01	16ms
REF6-0	Maximum gain at recovery operation	47H	+27.5dB	47H	+27.5dB
IPGA6-0	IPGA gain at the start of ALC1 operation	10H	0dB	10H	0dB
LMAT1-0	Limiter ATT Step	00	1 step	00	1 step
RATT	Recovery GAIN Step	0	1 step	0	1 step
ALC1	ALC1 Enable bit	1	Enable	1	Enable

Table 15. Examples of the ALC1 Setting

The following registers should not be changed during the ALC1 operation. These bits should be changed, after the ALC1 operation is finished by ALC1 bit = "0" or PMMIC bit = "0".

• **LTM1-0, LMTH, LMAT1-0, WTM1-0, ZTM1-0, RATT, REF6-0, ZELM bits**

When setting IPGA gain at the start of ALC1 operation, IPGA6-0 bits should be set while PMMIC bit is "1" and ALC1 bit is "0". When PMMIC bit = "1", IPGA6-0 bits value are not reflected to IPGA. When ALC1 bit is changed from "1" to "0", IPGA holds the last gain value set automatically by ALC1 operation.

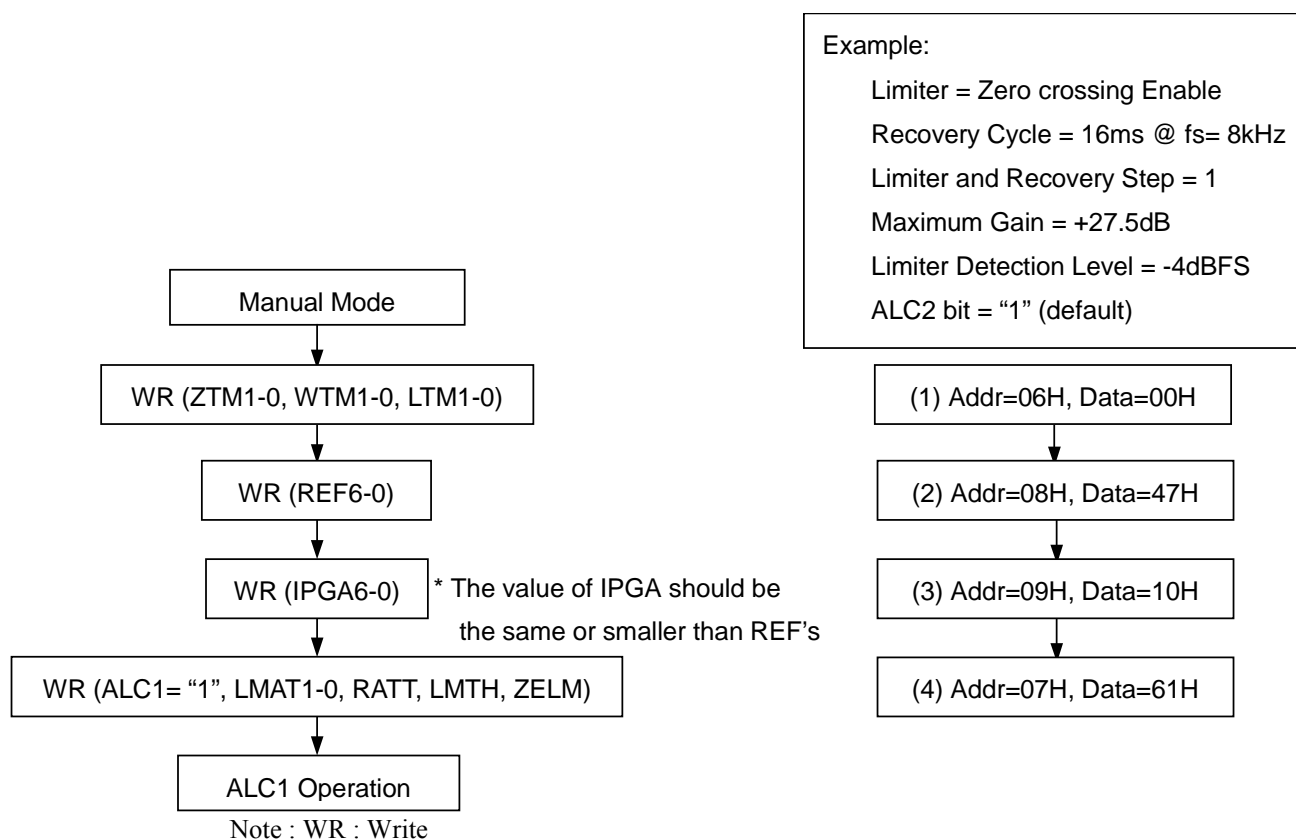

Figure 30. Registers set-up sequence at the ALC1 operation

## ■ Digital Output Volume

The AK4631 has a digital output volume (256 levels, 0.5dB step, Mute). The volume can be set by the DVOL7-0 bits. The volume control is in front of the DAC, and it can change the input data from +12dB to -115dB and mute. This volume has a soft transition function. It takes  $1061/f_s$  or  $256/f_s$  from 00H to FFH.

DVOL7-0	Gain
00H	+12.0dB
01H	+11.5dB
02H	+11.0dB
:	:
18H	0dB
:	:
FDH	-114.5dB
FEH	-115.0dB
FFH	MUTE ( $-\infty$ )

(default)

Table 16. Digital Output Volume Code Table

DVTM bit	The transition time from 00H to FFH of DVOL7-0 bits		
	Transition Time	$f_s=8\text{kHz}$	$f_s=22.05\text{kHz}$
0	$1061/f_s$	133msec	48msec
1	$256/f_s$	32msec	12msec

Table 17. Setting of transition time

## ■ BEEP Input

When the PMBP bit is set to “1”, the beep input is powered-up. When the BEEPS bit is set to “1”, the input signal from the BEEP pin is output to Speaker-Amp. When the BEEPA bit is set to “1”, the input signal from the BEEP pin is output to the mono line output amplifier. The external resistor  $R_i$  adjusts the signal level of BEEP input. The gains are shown in Table 18, when  $R_i = 20\text{k}\Omega$ . These gain are in inverse proportion to  $R_i$ .

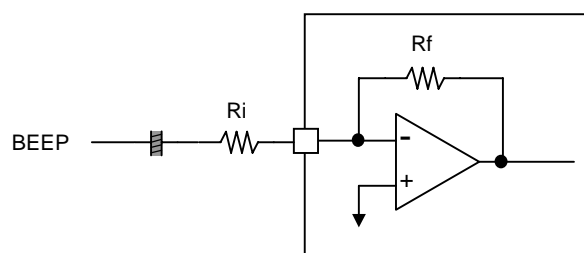

Figure 31. Block Diagram of BEEP pin

SPKG1-0 bits	BEEP → SPP/SPN Gain	BEEP → AOUT Gain
00	+7.89dB	0dB
01	+9.93dB	0dB
10	+14.11dB	0dB
11	+16.15dB	0dB

Table 18. Beep input gain at  $R_i = 20\text{k}\Omega$

## ■ Mono Line Output (AOUT pin)

A signal of DAC is output from the AOUT pin. When the DACA bit is “0”, this output is OFF. The load resistance is 10kΩ(min). When PMAO bit is “0” and AOPSN bit is “0”, the mono line output enters power-down and is pulled down by 100Ω(typ). If PMAO bit is controlled at AOPSN bit = “1”, POP noise will be reduced at power-up and down. Then, this line should be pulled down by 20kΩ of resistor after C-coupling shown in Figure 32. This rising and falling time is max 300 ms at C=1.0μF. When PMAO bit is “1” and AOPSN bit is “0”, the mono line output enters power-up state.

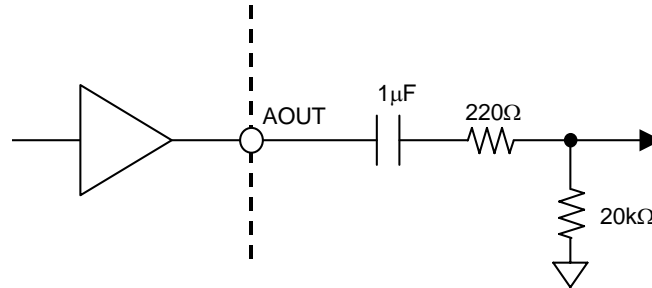

Figure 32. AOUT external circuit in case of using POP Reduction function.

### AOUT Control Sequence in case of using POP Reduction Circuit

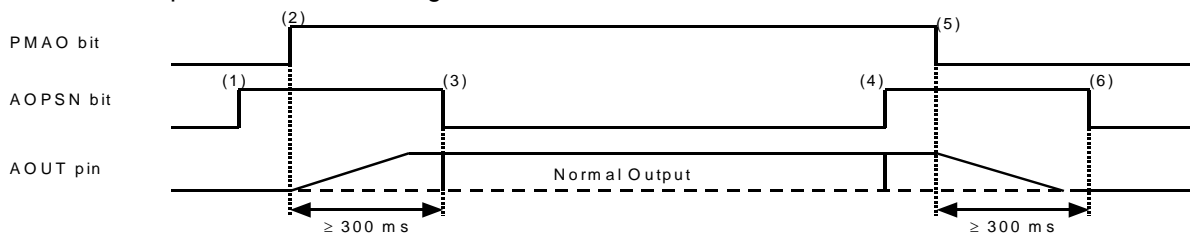

Figure 33. Mono Line Output Control Sequence in case of using POP Reduction function..

- (1) Set AOPSN bit = “1”. Mono line output enters the power-save mode.
- (2) Set PMAO bit = “1”. Mono line output exits the power-down mode.  
The AOUT pin rises up to VCOM voltage. Rise time is 200ms (max 300ms) at C=1μF.
- (3) Set AOPSN bit = “0” after AOUT pin rises up. Mono line output exits the power-save mode.  
Mono line output is enabled.
- (4) Set AOPSN bit = “1”. Mono line output enters power-save mode.
- (5) Set PMAO bit = “1”. Mono line output enters power-down mode.  
The AOUT pin falls down to AVSS. Fall time is 200ms (max 300ms) at C=1μF.
- (6) Set AOPSN bit = “0” after the AOUT pin falls down. Mono line output exits the power-save mode.

## ■ Speaker Output

The power supply voltage for Speaker-Amp, SVDD can be set to from 2.6V to 5.25V. However, SVDD should be set to from 2.6V to 3.6V, when the load resistance is less than 50Ω(ex. a dynamic speaker).

The output signal from DAC is input to the Speaker-amp via the ALC2 circuit. This Speaker-amp is a mono output controlled by BTL and a gain of the Speaker-Amp is set by SPKG1-0 bit. In the case of ALC2 OFF, the output voltage depends on AVDD and SPKG1-0 bits. In the case of ALC2 ON, the output voltage depends on SVDD and SPKG1-0 bits. The output level of ALC2 is proportional to SVDD.

SPKG1-0 bits	Gain
00	0dB
01	+2.04dB
10	+6.22dB
11	+8.26dB

(Note) These Gain from the level at SPKG1-0bits= "00".

Table 19. Gain of Speaker-Amp at ALC2 OFF

SPKG1-0 bits	AVDD	SVDD	Output Voltage from Speaker-Amp at ALC2 OFF and DAC Input=-0.5dBFS	Output Voltage from Speaker-Amp at ALC ON
00	3.3V	3.3V	3.09Vpp, 150mW@8Ω	3.09Vpp, 150mW@8Ω
01	3.3V	3.3V	3.92Vpp, 240mW@8Ω	3.92Vpp, 240mW@8Ω
10	3.3V	3.3V	6.34Vpp (Note)	Not Available
11	3.3V	3.3V	8.02Vpp (Note)	Not Available
00	3.3V	5.0V	3.09Vpp	Not Available
01	3.3V	5.0V	3.92Vpp	Not Available
10	3.3V	5.0V	6.34Vpp	6.34Vpp
11	3.3V	5.0V	8.02Vpp	8.02Vpp

(Note) This output voltage is assumed that the signal is not clipped. In actual, the signal will be clipped when DAC outputs 0dBFS signal. In order to avoid this clipping, Speaker-Amp output voltage should be attenuated to less than 3.92Vpp by the digital volume.

Table 20 Speaker-Amp Output Voltage

### [Caution for using Piezo Speaker]

When a piezo speaker (load capacitance > 30pF) is used, resistances more than 10Ω should be inserted between SPP/SPN pins and speaker in series, respectively, as shown in [Figure 34](#). Zener diodes should be inserted between speaker and GND as shown in [Figure 34](#), in order to protect SPK-Amp of the AK4631 from the power that the piezo speaker outputs when the speaker is pressured. Zener diodes of the following Zener voltage should be used.

$$92\% \text{ of SVDD} \leq \text{Zener voltage of Zener diode(ZD of Figure 34)} \leq \text{SVDD} + 0.3\text{V}$$

Ex) In case of SVDD = 5.0V : 4.6V ≤ ZD ≤ 5.3V

For example, Zener diode which Zener voltage is 5.1V(Min :4.97V, Max 5.24V) can be used.

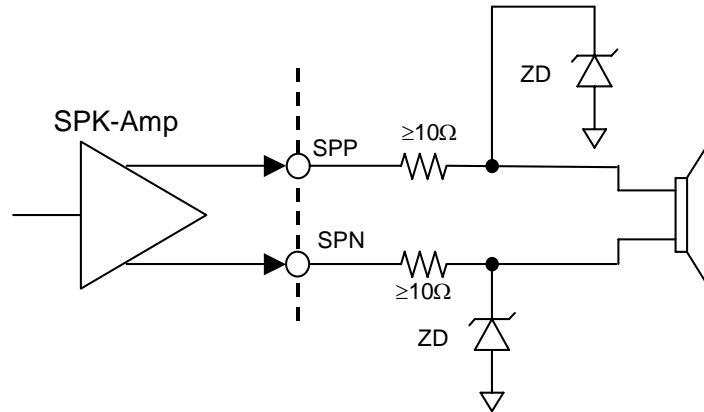

Figure 34. Circuit of Speaker Output(Load Capacitance > 30pF)

<Control Sequence of Speaker Amp>

Speaker blocks (MOUT, ALC2 and Speaker-amp) can be powered-up/down by controlling the PMSPK bit. When the PMSPK bit is “0”, the MOUT, SPP and SPN pins are placed in a Hi-Z state.

When the PMSPK bit is “1” and SPPS bit is “0”, the Speaker-amp enters power-save-mode. In this mode, the SPP pin is placed in a Hi-Z state and the SPN pin goes to SVDD/2 voltage. And then the Speaker output gradually changes to the SVDD/2 voltage and this mode can reduce pop noise at power-up. When the AK4631 is powered-down, pop noise can be also reduced by first entering power-save-mode.

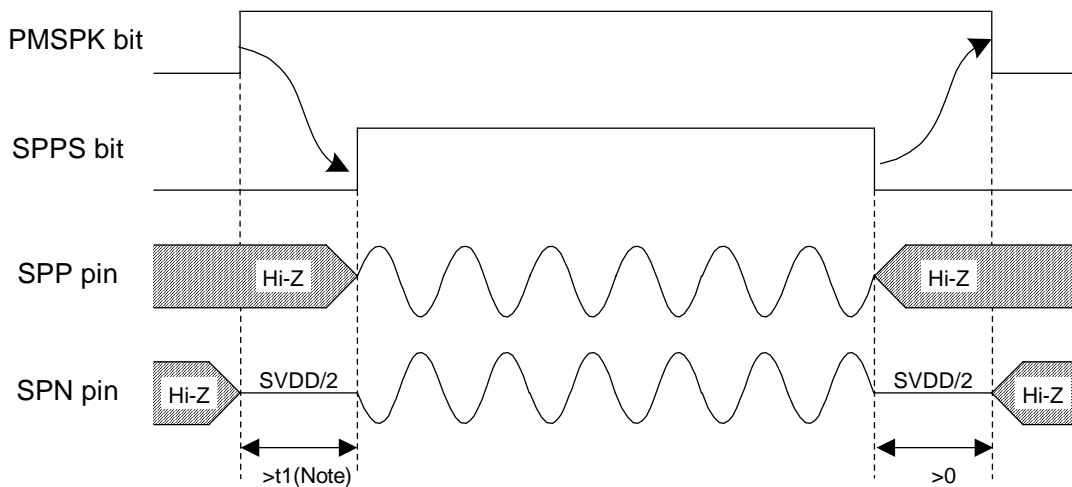

Figure 35. Power-up/Power-down Timing for Speaker-Amp

(Note)

“t1” depends on the time constant of input resistance of MIN and capacitor between the MOUT pin and MIN pin. If Speaker-Amp output is enabled before MIN-Amp (ALC2) becomes stable, pop noise may occur.

Ex) C of MOUT pin – MIN pin = 0.1 μF, Input resistance of MIN pin = 36kΩ(Max) : t1 = 5τ = 18ms  
 C of MOUT pin – MIN pin and the Input resistance(Rin) of MIN pin compose of HPF which cut off frequency(fc) are the followings.

fc = 66Hz@Rin=24kΩ(typ), 133Hz@Rin=12kΩ(min), 44Hz@Rin=36kΩ(max)

## ■ SPK-ALC Operation

The ALC (Automatic Level Control) operation of speaker output is executed by ALC2 block when ALC2 bit is “1”. Input resistance of the ALC2 is 24kΩ (typ) and centered around VCOM voltage. The ALC2 level diagram is shown in [Figure 36 ~Figure 39](#).

The limiter detection level is proportional to SVDD voltage. The output level is limited by the ALC2 circuit when the input signal exceeds -7.1dBV (@SPKG1 bit = “0”, SVDD=3.3V or @SPKG1 bit = “1”, SVDD = 5V). When a continuous signal of -7.1dBV or greater is input to the ALC2 circuit, the change period of the ALC2 limiter operation is 250μs (=2/fs@fs=8kHz) and the attenuation level is 0.5dB/step.

The ALC2 recovery operation uses zero crossings and gains of 1dB/step. The ALC2 recovery operation is executed until the input level of the Speaker-amp goes to -9.1dBV (@SPKG1 bit = “0”, SVDD=3.3V or @SPKG1 bit = “1”, SVDD = 5V). Maximum gain of the ALC2 recovery operation is set by RFS5-0 bits.

When the input signal is between -9.1dBV and -7.1dBV, the ALC2 limiter or recovery operations are not executed.

When the PMSPK bit changes from “0” to “1”, the initialization cycle ( $512/fs = 64ms$  @fs=8kHz at ROTM bit = “0”) starts. The ALC2 is disabled (The ALC2 gain is fixed to “-3.5dB”) during the initialization cycle and the ALC2 starts from “-2dB” after completing the initialization cycle. The ROTM bit and RFS5-0 bits set during the PMSPK bit = “0”.

When the ALC2 is disable, a gain of the ALC2 block is fixed to -3.5dB. Therefore, a gain of internal speaker block is shown in [Table 22](#).

Parameter		ALC2 Limiter operation	ALC2 Recovery operation
Operation Start Level		-5.2dBV	-7.2dBV
Period	fs=8kHz	$2/fs = 250\mu s$	$512/fs=64ms$
	fs=16kHz	$2/fs = 125\mu s$	$512/fs=32ms$
Zero-crossing Detection		No	Yes (Timeout = Period Time)
ATT/GAIN		0.5dB step	1dB step

Table 21. Limiter /Recovery of ALC2 (ROTM bit = “0”)

SPKG1-0 bits	Gain
00	+4.4dB
01	+6.4dB
10	+10.6dB
11	+12.7dB

Table 22. Gain of Speaker-Amp at ALC2 OFF(Full-differential Output)

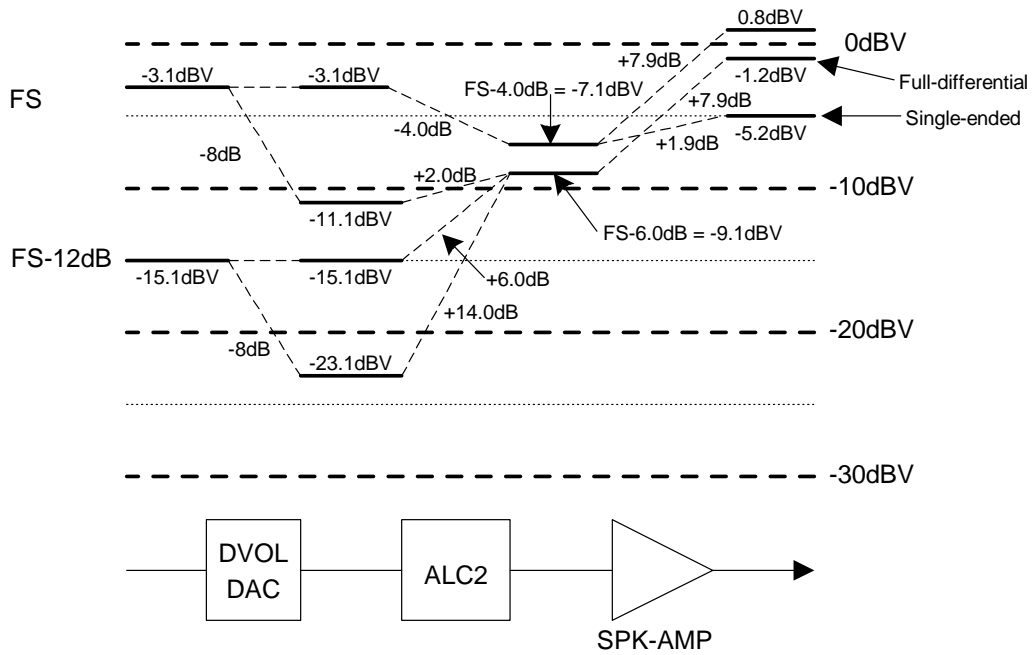

(AVDD=3.3V, SVDD=3.3V, DVOL=-8.0dB/0dB, SPKG1-0 bit = "00") \* FS = Full Scale

Figure 36. Speaker-Amp Output Level Diagram

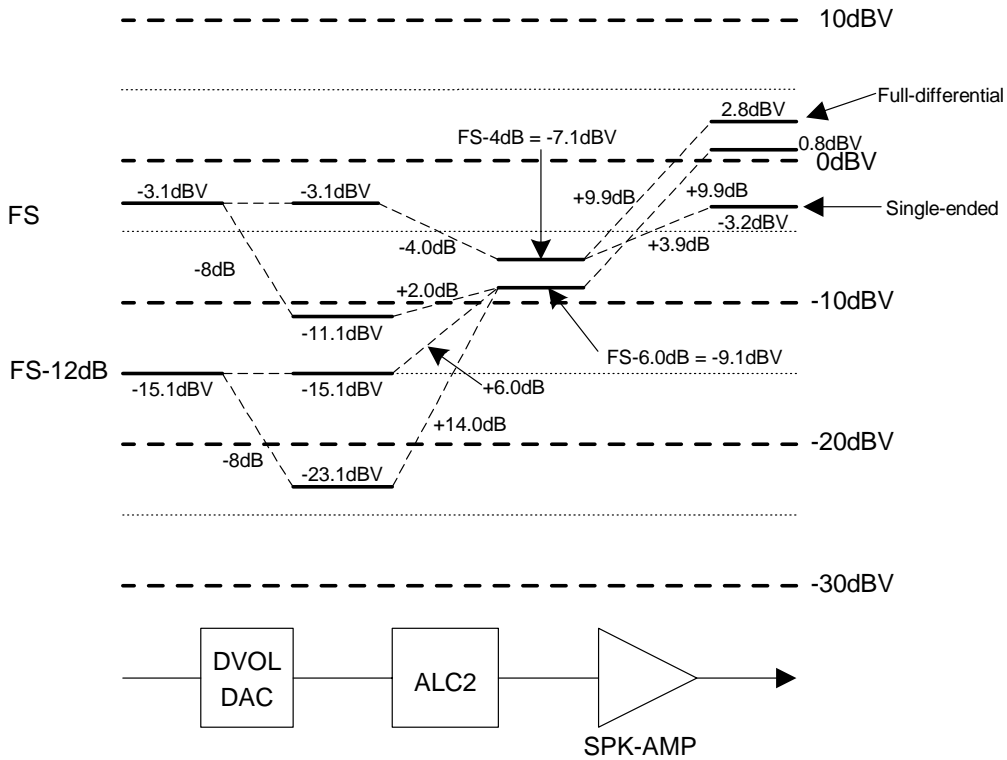

(AVDD=3.3V, SVDD=3.3V, DVOL=-8.0dB/0dB, SPKG1-0 bit = "01") \* FS = Full Scale

Figure 37. Speaker-Amp Output Level Diagram

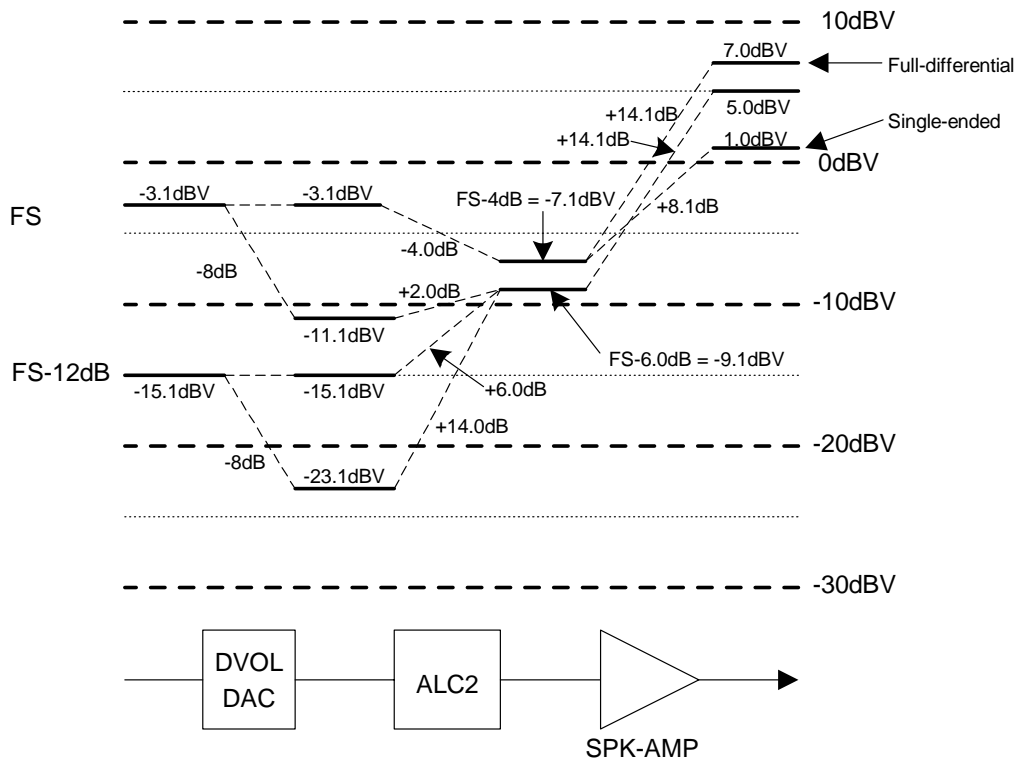

(AVDD=3.3V, SVDD=5.0V, DVOL=-8.0dB/0dB, SPKG1-0 bit = "10",) \* FS = Full Scale  
 Figure 38. Speaker-Amp Output Level Diagram

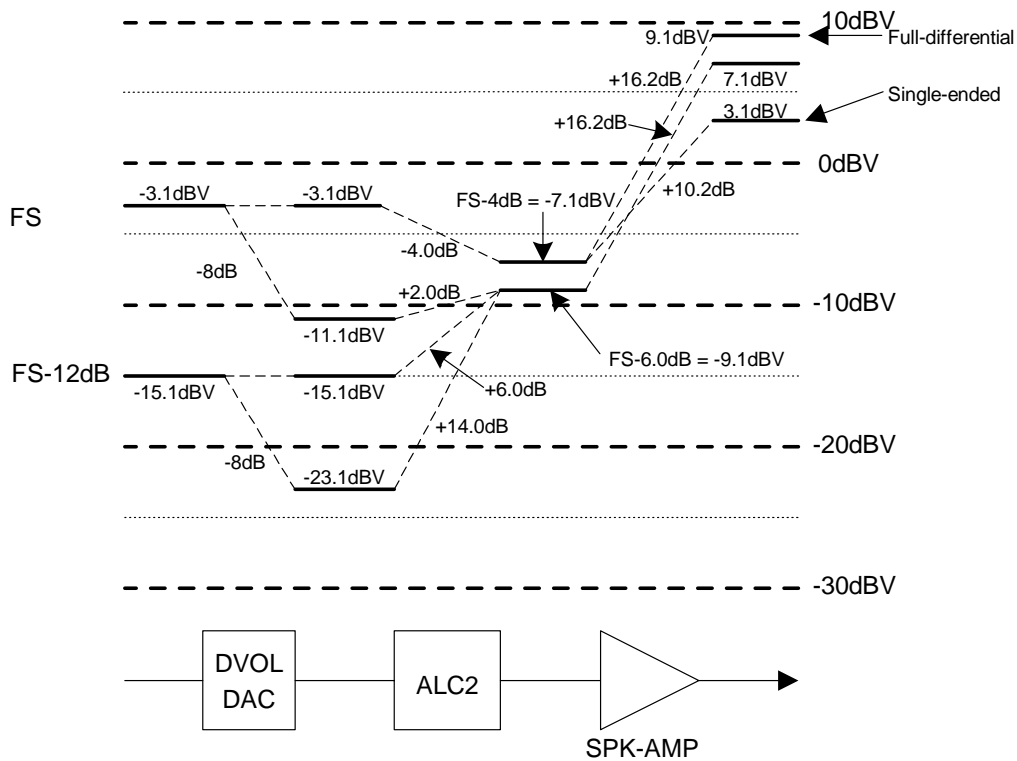

(AVDD=3.3V, SVDD=5.0V, DVOL=-8.0dB/0dB, SPKG1-0 bit = "11",) \* FS = Full Scale  
 Figure 39. Speaker-Amp Output Level Diagram

## ■ Serial Control Interface

Internal registers may be written by using the 3-wire  $\mu$ P interface pins (CSN, CCLK and CDTI). The data on this interface consists of a 2-bit Chip address (Fixed to "10"), Read/Write (Fixed to "1"), Register address (MSB first, 5bits) and Control data (MSB first, 8bits). Address and data is clocked in on the rising edge of CCLK and data is clocked out on the falling edge. The clock speed of CCLK is 5MHz (max). The value of internal registers is initialized at the PDN pin = "L".

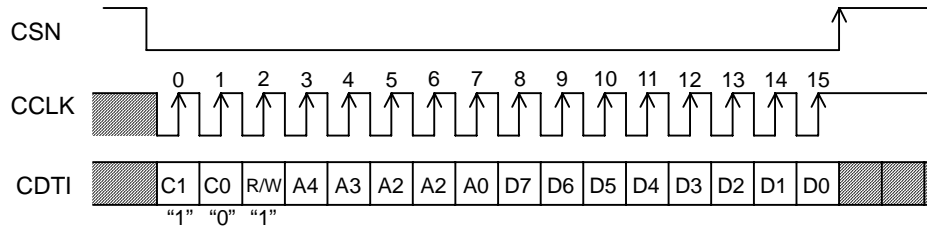

C1-C0: Chip Address (C1 = "1", C0 = "0"); Fixed to "10"  
 R/W: READ/WRITE ("1": WRITE, "0": READ); Fixed to "1"  
 A4-A0: Register Address  
 D7-D0: Control data

Figure 40. Serial Control I/F Timing

## ■ Register Map

Addr	Register Name	D7	D6	D5	D4	D3	D2	D1	D0
00H	Power Management 1	0	PMVCM	PMBP	PMSPK	PMAO	PMDAC	PMMIC	PMADC
01H	Power Management 2	0	0	0	0	M/S	MCKPD	MCKO	PMPLL
02H	Signal Select 1	SPPS	BEEPS	ALC2S	DACA	DACM	MPWR	MICAD	MGAIN0
03H	Signal Select 2	0	AOPSN	MGAIN1	SPKG1	SPKG0	BEEPA	ALC1M	ALC1A
04H	Mode Control 1	PLL3	PLL2	PLL1	PLL0	BCKO1	BCKO0	DIF1	DIF0
05H	Mode Control 2	0	0	FS3	MSBS	BCKP	FS2	FS1	FS0
06H	Timer Select	DVTM	ROTM	ZTM1	ZTM0	WTM1	WTM0	LTM1	LTM0
07H	ALC Mode Control 1	0	ALC2	ALC1	ZELM	LMAT1	LMAT0	RATT	LMTH
08H	ALC Mode Control 2	0	REF6	REF5	REF4	REF3	REF2	REF1	REF0
09H	Input PGA Control	0	IPGA6	IPGA5	IPGA4	IPGA3	IPGA2	IPGA1	IPGA0
0AH	Digital Volume Control	DVOL7	DVOL6	DVOL5	DVOL4	DVOL3	DVOL2	DVOL1	DVOL0
0BH	ALC2 Mode Control	0	0	RFS5	RFS4	RFS3	RFS2	RFS1	RFS0

The PDN pin = “L” resets the registers to their default values.

Note: The bits defined as 0 must contain a “0” value.

Note: Only write to address 00H to 0BH.

## ■ Register Definitions

Addr	Register Name	D7	D6	D5	D4	D3	D2	D1	D0
00H	Power Management 1	0	PMVCM	PMBP	PMSPK	PMAO	PMDAC	PMMIC	PMADC
	Default	0	0	0	0	0	0	0	0

PMADC: ADC Block Power Control

0: Power down (default)

1: Power up

When the PMADC bit changes from “0” to “1”, the initialization cycle ( $1059/f_s=133\text{ms}@8\text{kHz}$ ) starts. After initializing, digital data of the ADC is output.

PMMIC: MIC In Block (MIC-Amp and ALC1) Power Control

0: Power down (default)

1: Power up

PMDAC: DAC Block Power Control

0: Power down (default)

1: Power up

PMAO: Mono Line Out Power Control

0: Power down (default)

1: Power up

PMSPK: Speaker Block Power Control

0: Power down (default)

1: Power up

PMBP: BEEP In Power Control

0: Power down (default)

1: Power up

Even if PMBP bit is “0”, the path is still connected between BEEP and AOUT/SPK-Amp. BEEPS and BEEPA bits should be set to “0” to disconnect these paths.

PMVCM: VCOM Block Power Control

0: Power down (default)

1: Power up

Each block can be powered-down respectively by writing “0” to each bit. When the PDN pin is “L”, all blocks are powered-down.

When PMPLL and MCKO bits and all bits in 00H address are “0”, all blocks are powered-down. Though the IPGA resistors are initialized, the other registers remain unchanged. (refer to the IPGA6-0 bits description)

When any of the blocks are powered-up, the PMVCM bit must be set to “1”. When PMPLL and MCKO bits and all bits in 00H address are “0”, PMVCM bit can write to “0”.

When BEEP signal is output from Speaker-Amp (Signal path: BEEP pin → SPP/SPN pins) or Mono Lineout-Amp (Signal path: BEEP pin → AOUT pin) only, the clocks may not be present. When ADC, DAC, ALC1 or ALC2 is in operation, the clocks must always be present.

Addr	Register Name	D7	D6	D5	D4	D3	D2	D1	D0
01H	Power Management 2	0	0	0	0	M/S	MCKPD	MCKO	PMPLL
	Default	0	0	0	0	0	1	0	0

PMPLL: PLL Block Power Control Select

0: PLL is Power down and External is selected. (default)

1: PLL is Power up and PLL Mode is selected.

MCKO: Master Clock Output Enable

0: "L" Output (default)

1: 256fs Output

MCKPD: MCKI pin pull down control

0: Master Clock input enable

1: Pull down by 25k $\Omega$  (typ.) (default)

M/S: Select Master / Slave Mode

0: Slave Mode (default)

1: Master Mode

Addr	Register Name	D7	D6	D5	D4	D3	D2	D1	D0
02H	Signal Select 1	SPPS	BEEPS	ALC2S	DACA	DACM	MPWR	MICAD	MGAIN0
	Default	0	0	0	0	0	0	0	1

MGAIN1-0 : 1<sup>st</sup> MIC-amp Gain control([Table 23](#))

MGAIN 1 bit is located at D6 bit of 03H

MGAIN1 bit	MGAIN0 bit	Input Gain
0	0	0dB
0	1	+20dB
1	0	+26dB
1	1	+32dB

(default)

Table 23. Input Gain

MICAD: Switch Control from MIC In to ADC.

0: OFF (default)

1: ON

When MICAD bit is “1”, the ALC1 output signal is input to ADC.

MPWR: Power Supply Control for Microphone

0: OFF (default)

1: ON

When PMMIC bit is “1”, MPWR bit is enabled.

DACM: Switch Control from DAC to mono amp.

0: OFF (default)

1: ON

When PMSPK bit is “1”, DACM bit is enabled. When PMSPK bit is “0”, the MOUT pin is Hi-Z state.

DACA: Switch Control from DAC to mono line amp

0: OFF (default)

1: ON

When PMAO bit is “1”, DACA bit is enabled. When PMAO bit is “0”, the AOUT pin is AVSS.

ALC2S: ALC2 output to Speaker-Amp Enable

0: OFF (default)

1: ON

When ALC2S bit is “1”, the ALC2 output signal is input to Speaker-Amp.

BEEPS: BEEP pin to Speaker-Amp Enable

0: OFF (default)

1: ON

When BEEPS bit is “1”, the beep signal is input to Speaker-Amp.

SPPS: Speaker-amp Power-Save-Mode

0: Power Save Mode (default)

1: Normal Operation

When SPPS bit is “0”, the Speaker-amp is in power-save-mode and the SPP pin becomes Hi-z and SPN pin is set to SVDD/2 voltage. When the PMSPK bit = “1”, this bit is valid. After the PDN pin changes from “L” to “H”, the PMSPK bit is “0”, which powers down Speaker-amp.

Addr	Register Name	D7	D6	D5	D4	D3	D2	D1	D0
03H	Signal Select 2	0	AOPSN	MGAIN1	SPKG1	SPKG0	BEEPA	ALC1M	ALC1A
	Default	0	0	0	0	0	0	0	0

ALC1A: Switch Control from ALC1 output signal to mono line output amp.

0: OFF (default)

1: ON

When PMAO bit is “1”, ALC1A bit is enabled. When PMAO bit is “0”, the AOUT pin is AVSS.

ALC1M: Switch Control from ALC1 output signal to mono amp.

0: OFF (default)

1: ON

When PMSPK bit is “1”, ALC1M is enabled. When PMSPK bit is “0”, the MOUT pin goes Hi-Z state.

BEEPA: Switch Control from beep signal to mono line output amp.

0: OFF (default)

1: ON

When PMAO bit is “1”, BEEPA is enabled. When PMAO bit is “0”, the AOUT pin is AVSS.

SPKG1-0: Select Speaker-Amp Output Gain ([Table 24](#))

SPKG1-0 bits	Gain
00	0dB
01	+2.2dB
10	+4.4dB
11	+8.7dB

Table 24. Gain of Speaker-Amp

MGAIN1: Mic-Amplifier Gain Control ([Table 23](#))

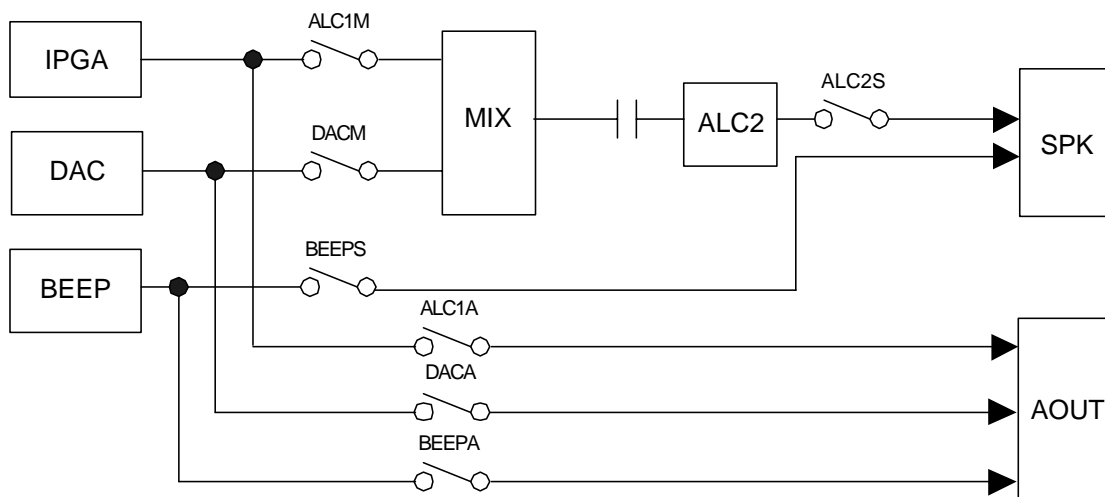

Figure 41. Speaker and Mono Lineout-Amps switch control

**AOPSN: Mono Line Output Power-Save Mode**

0: Normal Operation (default)

1: Power-Save Mode

Power-save mode is enable at AOPSN bit = “1”. POP noise at power-up/down can be reduced by changing at AOPSN bit = “1”. (Figure 33)

Addr	Register Name	D7	D6	D5	D4	D3	D2	D1	D0
04H	Mode Control 1	PLL3	PLL2	PLL1	PLL0	BCKO1	BCKO0	DIF1	DIF0
	Default	0	0	0	0	0	0	1	0

DIF1-0: Audio Interface Format (Table 25)

Mode	DIF1 bit	DIF0 bit	SDTO (ADC)	SDTI (DAC)	BICK	Figure
0	0	0	DSP Mode	DSP Mode	$\geq 16fs$	See Table 31
1	0	1	MSB justified	LSB justified	$\geq 32fs$	Figure 26
2	1	0	MSB justified	MSB justified	$\geq 32fs$	Figure 27 (default)
3	1	1	I <sup>2</sup> S compatible	I <sup>2</sup> S compatible	$\geq 32fs$	Figure 28

Table 25. Audio Interface Format

BCKO1-0: Select BICK output frequency at Master Mode (Table 26)

Mode	BCKO1 bit	BCKO0 bit	BICK Output Frequency
0	0	0	16fs
1	0	1	32fs
2	1	0	64fs
3	1	1	N/A

(default)

Table 26. BICK Output Frequency at Master Mode

PLL3-0: Select input frequency at PLL mode (Table 27)

Mode	PLL3 bit	PLL2 bit	PLL1 bit	PLL0 bit	PLL Reference Clock Input Pin	Input Frequency
0	0	0	0	0	FCK pin	1fs
1	0	0	0	1	BICK pin	16fs
2	0	0	1	0	BICK pin	32fs
3	0	0	1	1	BICK pin	64fs
4	0	1	0	0	MCKI pin	11.2896MHz
5	0	1	0	1	MCKI pin	12.288MHz
6	0	1	1	0	MCKI pin	12MHz
7	0	1	1	1	MCKI pin	24MHz
12	1	1	0	0	MCKI pin	13.5MHz
13	1	1	0	1	MCKI pin	27MHz
Others	Others				N/A	

(default)

Table 27. Setting of PLL Mode (\*fs: Sampling Frequency)

Addr	Register Name	D7	D6	D5	D4	D3	D2	D1	D0
05H	Mode Control 2	0	0	FS3	MSBS	BCKP	FS2	FS1	FS0
	Default	0	0	0	0	0	0	0	0

FS3-0: Setting of Sampling Frequency (Table 28 and Table 29) and MCKI Frequency (Table 30)

These bits are selected to sampling frequency at PLL mode and MCKI frequency at EXT mode.

Mode	FS3 bit	FS2 bit	FS1 bit	FS0 bit	Sampling Frequency
0	0	0	0	0	8kHz
1	0	0	0	1	12kHz
2	0	0	1	0	16kHz
3	0	0	1	1	24kHz
4	0	1	0	0	7.35kHz
5	0	1	0	1	11.025kHz
6	0	1	1	0	14.7kHz
7	0	1	1	1	22.05kHz
10	1	0	1	0	32kHz
11	1	0	1	1	48kHz
14	1	1	1	0	29.4kHz
15	1	1	1	1	44.1kHz
Others	Others				N/A

Table 28. Setting of Sampling Frequency at PLL2 bit = "1" and PMPLL bit = "1"

Mode	FS3 bit	FS2 bit	FS1 bit	FS0 bit	Sampling Frequency Range
0	0	Don't care	0	0	$7.35\text{kHz} \leq fs \leq 8\text{kHz}$
1	0	Don't care	0	1	$8\text{kHz} < fs \leq 12\text{kHz}$
2	0	Don't care	1	0	$12\text{kHz} < fs \leq 16\text{kHz}$
3	0	Don't care	1	1	$16\text{kHz} < fs \leq 24\text{kHz}$
6	1	Don't care	1	0	$24\text{kHz} < fs \leq 32\text{kHz}$
7	1	Don't care	1	1	$32\text{kHz} < fs \leq 48\text{kHz}$
Others	Others				N/A

Table 29. Setting of Sampling Frequency at PLL2 bit = "0" and PMPLL bit = "1"

Mode	FS3-2 bits	FS1 bit	FS0 bit	MCKI Input Frequency	Sampling Frequency Range
0	Don't care	0	0	256fs	$7.35\text{kHz} \leq fs \leq 48\text{kHz}$
1	Don't care	0	1	1024fs	$7.35\text{kHz} < fs \leq 13\text{kHz}$
2	Don't care	1	0	256fs	$7.35\text{kHz} < fs \leq 48\text{kHz}$
3	Don't care	1	1	512fs	$7.35\text{kHz} < fs \leq 26\text{kHz}$

Table 30. MCKI Frequency at EXT Slave Mode (PMPLL bit = "0", M/S bit = "0")

BCKP, MSBS: "00" (default) (See Table 31)

MSBS bit	BCKP bit	Audio Interface Format
0	0	Figure 22
0	1	Figure 23
1	0	Figure 24
1	1	Figure 25

Table 31. Audio Interface Format in Mode 0

Addr	Register Name	D7	D6	D5	D4	D3	D2	D1	D0
06H	Timer Select	DVTM	ROTM	ZTM1	ZTM0	WTM1	WTM0	LTM1	LTM0
	Default	0	0	0	0	0	0	0	0

LTM1-0: ALC1 limiter operation period at zero crossing disable (ZELM bit = “1”) (Table 32)

The IPGA value is changed immediately. When the IPGA value is changed continuously, this change is executed in the period set by the LTM1-0 bits. Default is “00” (0.5/fs).

LTM1 bit	LTM0 bit	ALC1 Limiter Operation Period			
			8kHz	16kHz	
0	0	0.5/fs	63μs	31μs	(default)
0	1	1/fs	125μs	63μs	
1	0	2/fs	250μs	125μs	
1	1	4/fs	500μs	250μs	

Table 32. ALC1 Limiter Operation Period at zero crossing disable (ZELM bit=“1”)

WTM1-0: ALC1 Recovery Waiting Period (Table 33)

A period of recovery operation when any limiter operation does not occur during the ALC1 operation. Default is “00” (128/fs).

WTM1 bit	WTM0 bit	ALC1 Recovery Operation Waiting Period			
			8kHz	16kHz	
0	0	128/fs	16ms	8ms	(default)
0	1	256/fs	32ms	16ms	
1	0	512/fs	64ms	32ms	
1	1	1024/fs	128ms	64ms	

Table 33. ALC1 Recovery Operation Waiting Period

ZTM1-0: ALC1 Zero crossing timeout Period (Table 34)

When the IPGA perform zero crossing or timeout, the IPGA value is changed by the μP WRITE operation, ALC1 recovery operation or ALC1 limiter operation (ZELM bit = “0”). Default is “00” (128/fs).

ZTM1 bit	ZTM0 bit	Zero Crossing Timeout Period			
			8kHz	16kHz	
0	0	128/fs	16ms	8ms	(default)
0	1	256/fs	32ms	16ms	
1	0	512/fs	64ms	32ms	
1	1	1024/fs	128ms	64ms	

Table 34. Zero Crossing Timeout Period

ROTM: Period time for ALC2 Recovery operation, ALC2 Zero Crossing Timeout and ALC2 initializing cycle.

0: 512/fs (default)

1: 1024/fs

The ROTM bit is set during the PMSPK bit = “0”.

DVTM :Digital Volume Soft Transition Time Control

0: 1061/fs (default)

1: 256/fs

This is the time to FFH from 00H of DVOL7-0 bits.

Addr	Register Name	D7	D6	D5	D4	D3	D2	D1	D0
07H	ALC Mode Control 1	0	ALC2	ALC1	ZELM	LMAT1	LMAT0	RATT	LMTH
	Default	0	1	0	0	0	0	0	0

LMTH: ALC1 Limiter Detection Level / Recovery Waiting Counter Reset Level (Table 35)

The ALC1 limiter detection level and the ALC1 recovery counter reset level may be offset by about  $\pm 2$ dB. Default is “0”.

LMTH bit	ALC1 Limiter Detection Level	ALC1 Recovery Waiting Counter Reset Level	(default)
0	ADC Input $\geq -6.0$ dBFS	$-6.0$ dBFS > ADC Input $\geq -8.0$ dBFS	
1	ADC Input $\geq -4.0$ dBFS	$-4.0$ dBFS > ADC Input $\geq -6.0$ dBFS	

Table 35. ALC1 Limiter Detection Level / Recovery Waiting Counter Reset Level

RATT: ALC1 Recovery GAIN Step (Table 36)

During the ALC1 recovery operation, the number of steps changed from the current IPGA value is set. For example, when the current IPGA value is 30H and RATT bit = “1” is set, the IPGA changes to 32H by the ALC1 recovery operation and the output signal level is gained up by 1dB (=0.5dB x 2). When the IPGA value exceeds the reference level (REF6-0 bits), the IPGA value does not increase.

RATT bit	GAIN STEP	(default)
0	1	
1	2	

Table 36. ALC1 Recovery Gain Step Setting

LMAT1-0: ALC1 Limiter ATT Step (Table 37)

During the ALC1 limiter operation, when IPGA output signal exceeds the ALC1 limiter detection level set by LMTH, the number of steps attenuated from the current IPGA value is set. For example, when the current IPGA value is 47H and the LMAT1-0 bits = “11”, the IPGA transition to 43H when the ALC1 limiter operation starts, resulting in the input signal level being attenuated by 2dB (=0.5dB x 4). When the attenuation value exceeds IPGA = “00” (-8dB), it clips to “00”.

LMAT1 bit	LMAT0 bit	ATT STEP	(default)
0	0	1	
0	1	2	
1	0	3	
1	1	4	

Table 37. ALC1 Limiter ATT Step Setting

ZELM: Enable zero crossing detection at ALC1 Limiter operation

0: Enable (default)

1: Disable

When the ZELM bit = “0”, the IPGA of each L/R channel perform a zero crossing or timeout independently and the IPGA value is changed by the ALC1 operation. The zero crossing timeout is the same as the ALC1 recovery operation. When the ZELM bit = “1”, the IPGA value is changed immediately.

**ALC1: ALC1 Enable**

- 0: ALC1 Disable (default)
- 1: ALC1 Enable

When ALC1 bit is “1”, the ALC1 operation is enabled.

**ALC2: ALC2 Enable**

- 0: ALC2 Disable
- 1: ALC2 Enable (default)

After completing the initializing cycle ( $512/f_s = 64\text{ms}$  @ $f_s=8\text{kHz}$  at ROTM bit = “0”), the ALC2 operation is enabled. When the PMSPK bit changes from “0” to “1” or the PDN pin changes from “L” to “H”, the initialization cycle starts.

Addr	Register Name	D7	D6	D5	D4	D3	D2	D1	D0
08H	ALC Mode Control 2	0	REF6	REF5	REF4	REF3	REF2	REF1	REF0
	Default	0	0	1	1	0	1	1	0

**REF6-0: Reference value at ALC1 Recovery Operation (Table 38)**

During the ALC1 recovery operation, if the IPGA value exceeds the setting reference value by gain operation, the IPGA does not become larger than the reference value. For example, when REF7-0 = “30H”, RATT = 2step, IPGA = 2FH, even if the input signal does not exceed the “ALC1 Recovery Waiting Counter Reset Level”, the IPGA does not change to 2FH + 2step = 31H, and keeps 30H. Default is “36H”.

DATA (HEX)	GAIN (dB)	STEP
47	+27.5	(default)  0.5dB
46	+27.0	
45	+26.5	
:	:	
36	+19.0	
:	:	
10	+0.0	
:	:	
06	-5.0	
05	-5.5	
04	-6.0	
03	-6.5	
02	-7.0	
01	-7.5	
00	-8.0	

Table 38. Setting Reference Value at ALC1 Recovery Operation

Addr	Register Name	D7	D6	D5	D4	D3	D2	D1	D0
09H	Input PGA Control	0	IPGA6	IPGA5	IPGA4	IPGA3	IPGA2	IPGA1	IPGA0
	Default	0	0	0	1	0	0	0	0

#### IPGA6-0: Input Analog PGA (Table 39)

Default: "10H" (0dB)

When IPGA gain is changed, IPGA6-0 bits should be written while PMMIC bit is "1" and ALC1 bit is "0". IPGA6-0 bits should be set at  $2/f_s(250\mu s @ f_s=8kHz)$  after PMMIC bit is set to "1". IPGA gain is reset when PMMIC bit is "0", and then IPGA operation starts from the default value when PMMIC bit is changed to "1". When ALC1 bit is changed from "1" to "0", IPGA holds the last gain value set automatically by ALC1 operation.

In a manual mode, IPGA can be set to any values in Table 39. The ZTM1-0 bits set zero crossing timeout period when IPGA value is changed. When the control register is written from the  $\mu P$ , the zero crossing counter is reset and its counter starts. When the signal zero crossing or zero crossing timeout, the written value from the  $\mu P$  becomes valid.

DATA (HEX)	GAIN (dB)	STEP
47	+27.5	0.5dB (default)
46	+27.0	
45	+26.5	
:	:	
36	+19.0	
:	:	
10	+0.0	
:	:	
06	-5.0	
05	-5.5	
04	-6.0	
03	-6.5	
02	-7.0	
01	-7.5	
00	-8.0	

Table 39. Input Gain Setting

Addr	Register Name	D7	D6	D5	D4	D3	D2	D1	D0
0AH	Digital Volume Control	DVOL7	DVOL6	DVOL5	DVOL4	DVOL3	DVOL2	DVOL1	DVOL0
	Default	0	0	0	1	1	0	0	0

#### DVOL7-0: Output Digital Volume (Table 40)

The AK4631 has a digital output volume (256 levels, 0.5dB step, Mute). The gain can be set by the DVOL7-0 bits. The volume control is in front of the DAC, and it can change the input data from +12dB to -115dB and mute. This volume has a soft transition function. It takes  $1061/f_s (=133ms @ f_s = 8kHz)$  or  $256/f_s (=32ms @ f_s = 8kHz)$  from 00H to FFH. Soft Transition Time is set by DVTM bit.

DVOL7-0	Gain
00H	+12.0dB
01H	+11.5dB
02H	+11.0dB
:	:
18H	0dB (default)
:	:
FDH	-114.5dB
FEH	-115.0dB
FFH	MUTE ( $-\infty$ )

Table 40. Digital Volume Code Table

Addr	Register Name	D7	D6	D5	D4	D3	D2	D1	D0
0BH	ALC2 Mode Control	0	0	RFS5	RFS4	RFS3	RFS2	RFS1	RFS0
	Default	0	0	1	1	1	1	0	0

RFS6-0: Reference value at ALC2 Recovery Operation (Table 41)

REFS5-0 bits	Volume[dB]	Step
3F	+19.5	0.5dB (default)
3E	+19.0	
3D	+18.5	
3C	+18.0	
:	:	
19	+0.5	
18	+0.0	
17	-0.5	
:	:	
03	-10.5	
02	-11.0	
01	-11.5	
00	-12.0	

Table 41. Setting Reference Value at ALC2 Recovery Operation

## SYSTEM DESIGN

Figure 42 shows the system connection diagram. An evaluation board [AKD4631] is available which demonstrates the optimum layout, power supply arrangements and measurement results.

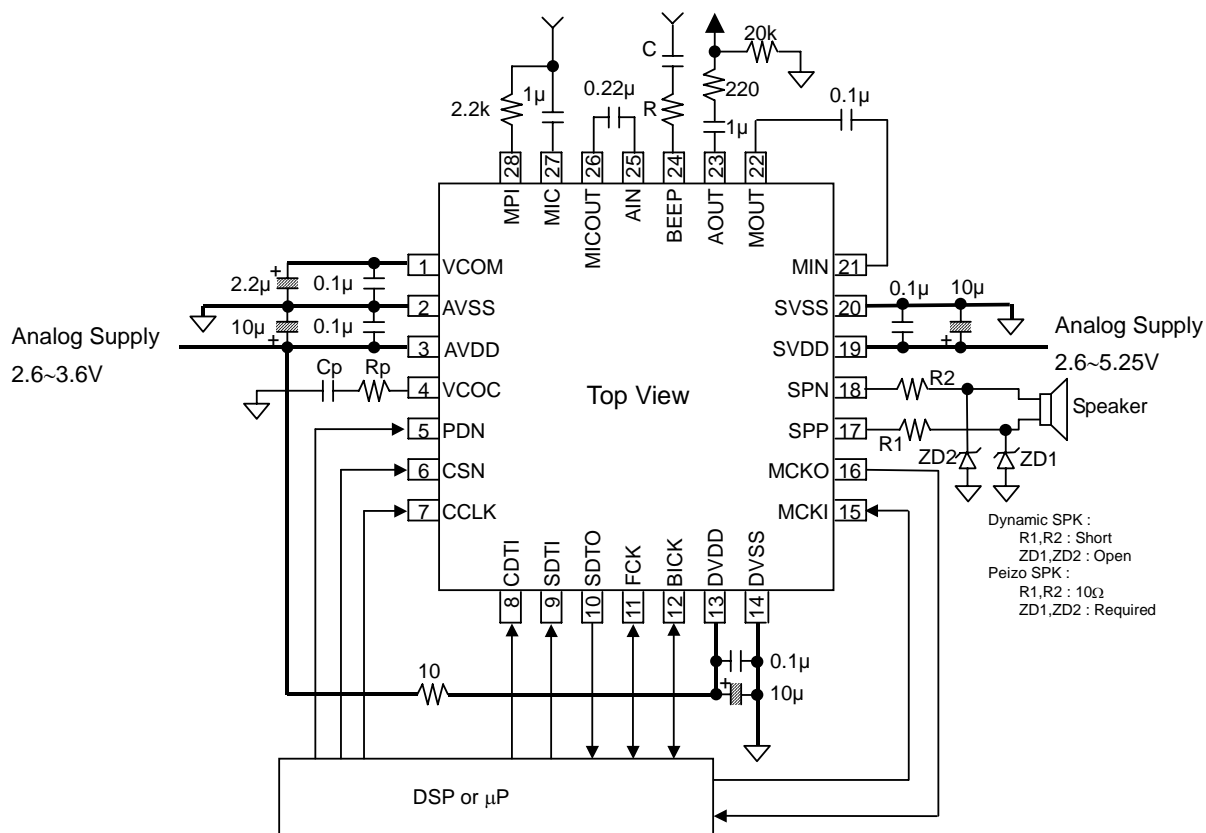

**Notes:**

- AVSS, DVSS and SVSS of the AK4631 should be distributed separately from the ground of external controllers.
- All digital input pins except pull-down pin should not be left floating.
- Value of R and C of BEEP pin should depend on system.
- When the AK4631 is EXT mode (PMPLL bit = "0"), a resistor and capacitor of VCOC pin is not needed.
- When the AK4631 is PLL mode (PMPLL bit = "1"), a resistor and capacitor of VCOC pin is shown in Table 42.
- Input resistance of AIN pin and Capacitance between MICOUT pin and AIN pin compose of HPF. When the capacitance is 0.22μF, the cut off frequency is typ.72Hz(typ)(min. 48Hz, max. 145Hz).

Mode	PLL3 bit	PLL2 bit	PLL1 bit	PLL0 bit	PLL Reference Clock Input Pin	Input Frequency	Rp and Cp of VCOC pin		PLL Lock Time (max)
							Rp[Ω]	Cp[F]	
0	0	0	0	0	FCK pin	1fs	6.8k	220n	160ms
1	0	0	0	1	BICK pin	16fs	10k	4.7n	2ms
2	0	0	1	0	BICK pin	32fs	10k	4.7n	2ms
3	0	0	1	1	BICK pin	64fs	10k	4.7n	2ms
4	0	1	0	0	MCKI pin	11.2896MHz	10k	4.7n	40ms
5	0	1	0	1	MCKI pin	12.288MHz	10k	4.7n	40ms
6	0	1	1	0	MCKI pin	12MHz	10k	4.7n	40ms
7	0	1	1	1	MCKI pin	24MHz	10k	4.7n	40ms
12	1	1	0	0	MCKI pin	13.5MHz	10k	10n	40ms
13	1	1	0	1	MCKI pin	27MHz	10k	10n	40ms
Others	Others				N/A				

(default)

Table 42. Setting of PLL Mode (\*fs: Sampling Frequency)

## 1. Grounding and Power Supply Decoupling

The AK4631 requires careful attention to power supply and grounding arrangements. AVDD, DVDD and SVDD are usually supplied from the system's analog supply. If AVDD, DVDD and SVDD are supplied separately, the correct power up sequence should be observed. AVSS, DVSS and SVSS of the AK4631 should be connected to the analog ground plane. System analog ground and digital ground should be connected together near to where the supplies are brought onto the printed circuit board. Decoupling capacitors should be as near to the AK4631 as possible, with the small value ceramic capacitor being the nearest.

## 2. Voltage Reference

VCOM is a signal ground of this chip. A 2.2 $\mu$ F electrolytic capacitor in parallel with a 0.1 $\mu$ F ceramic capacitor attached to the VCOM pin eliminates the effects of high frequency noise. No load current may be drawn from the VCOM pin. All signals, especially clocks, should be kept away from the VCOM pin in order to avoid unwanted coupling into the AK4631.

## 3. Analog Inputs

The Mic and Beep inputs are single-ended. The input signal range scales with nominally at 0.06 x AVDD Vpp for the Mic input and 0.6 x AVDD Vpp for the Beep input, centered around the internal common voltage (approx. 0.45 x AVDD). Usually the input signal is AC coupled using a capacitor. The cut-off frequency is  $f_c = 1/(2\pi RC)$ . The AK4631 can accept input voltages from AVSS to AVDD.

## 4. Analog Outputs

The input data format for the DAC is 2's complement. The output voltage is a positive full scale for 7FFFH(@16bit) and a negative full scale for 8000H(@16bit). Mono output from the MOUT pin and Mono Line Output from the AOOUT pin are centered at 0.45 x AVDD (typ). The Speaker-Amp output is centered at SVDD/2.

## CONTROL SEQUENCE

### ■ Clock Set Up

When ADC, DAC, ALC1, ALC2 and IPGA are used, the clocks must be supplied.

#### 1. In case of PLL Master Mode.

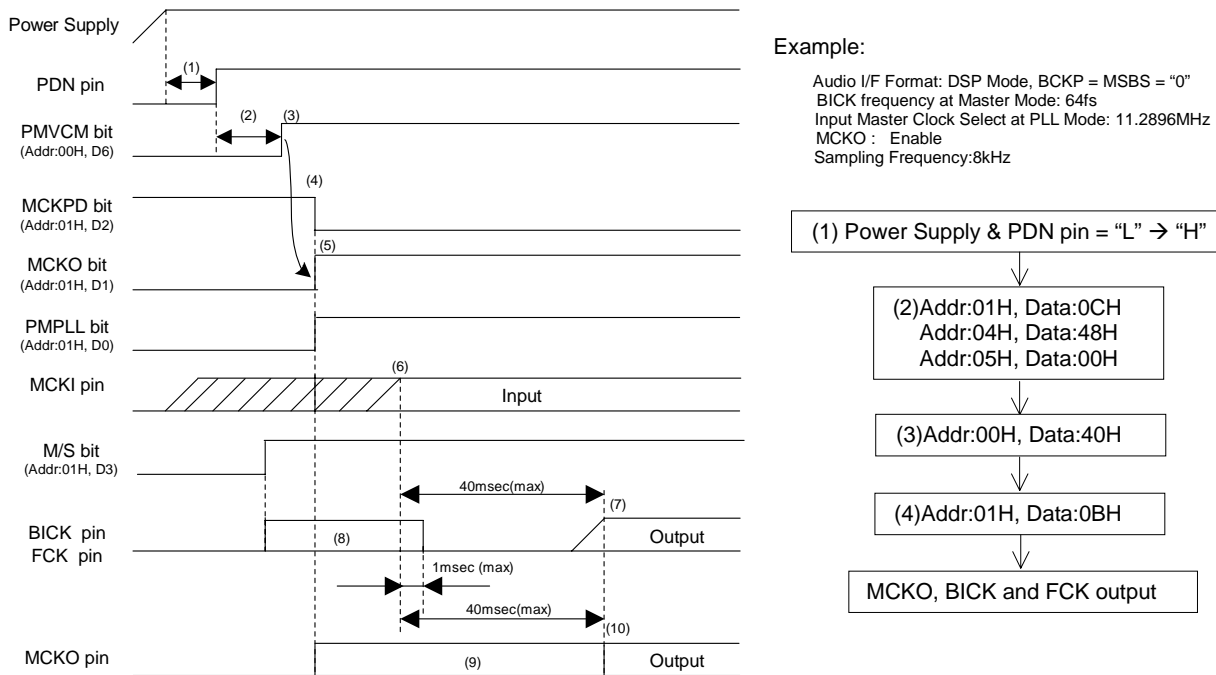

Figure 43. Clock Set Up Sequence (1)

#### <Example>

(1) After Power Up, PDN pin = "L" → "H"

"L" time (1) of 150ns or more is needed to reset the AK4631.

(2) DIF1-0, PLL3-0, FS3-0, BCKO1-0, MSBS, BCKP and M/S bits should be set during this period.

(3) Power Up VCOM: PMVCM bit = "0" → "1"

VCOM should first be powered-up before the other block operates.

(4) Release the pull-down resistor of the MCKI pin: MCKPD bit = "1" → "0"

(5) In case of using MCKO output: MCKO bit = "1"

In case of not using MCKO output: MCKO bit = "0"

(6) PLL lock time is 40ms(max) after PMPLL bit changes from "0" to "1" and MCKI is supplied from an external source.

(7) The AK4631 starts to output the FCK and BICK clocks after the PLL becomes stable. The normal operation of the block which a clock is necessary for becomes possible.

(8) The invalid frequencies are output from the FCK and BICK pins during this period.

(9) The invalid frequency is output from the MCKO pin during this period.

(10) The normal clock is output from the MCKO pin after the PLL is locked.

## 2. When the external clocks (FCK or BICK pin) are used in PLL Slave Mode.

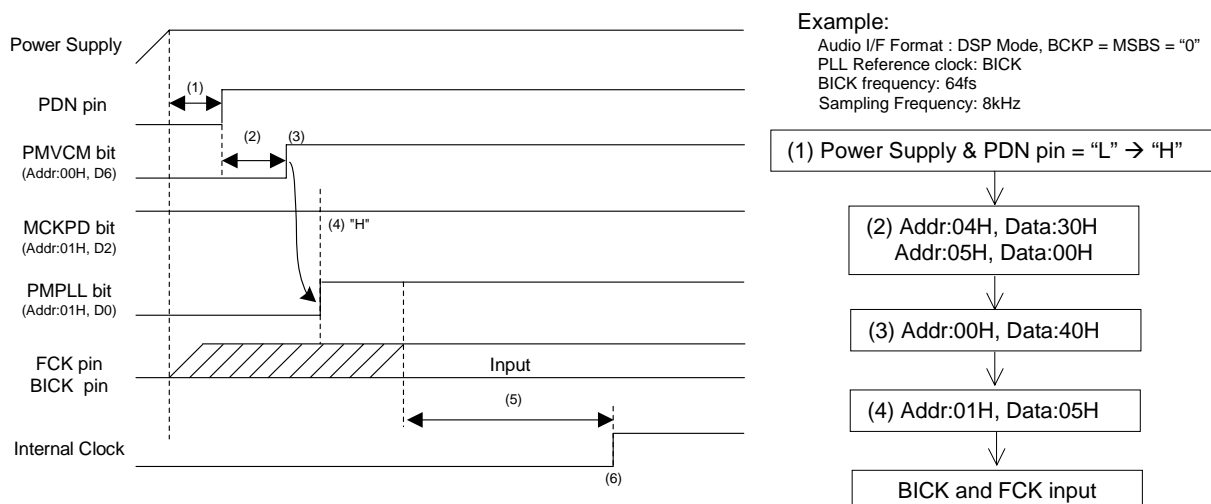

Figure 44. Clock Set Up Sequence (2)

## &lt;Example&gt;

(1) After Power Up: PDN pin "L" → "H"

"L" time (1) of 150ns or more is needed to reset the AK4631.

(2) DIF1-0, FS3-0, PLL3-0, MSBS and BCKP bits should be set during this period.

(3) Power Up VCOM: PMVCM bit = "0" → "1"

VCOM should first be powered up before the other block operates.

(4) Pull down of the MCKI pin: MCKPD bit = "1"

(5) PLL starts after the PMPLL bit changes from "0" to "1" and PLL reference clock (FCK or BICK pin) is supplied.

PLL lock time is 160ms(max) when FCK is a PLL reference clock. And PLL lock time is 2ms(max) when BICK is a PLL reference clock.

(6) Normal operation starts after the PLL is locked.

## 3. When the external clock (MCKI pin) is used in PLL Slave Mode.

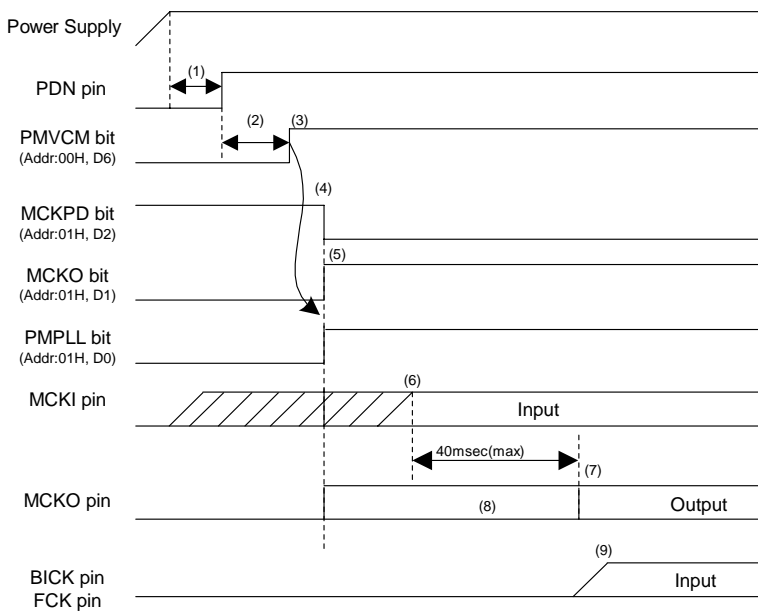

## Example:

Audio I/F Format: DSP Mode, BCKP = MSBS = "0"  
 BICK frequency at Master Mode: 64fs  
 Input Master Clock Select at PLL Mode: 11.2896MHz  
 MCKO : Enable  
 Sampling Frequency:8kHz

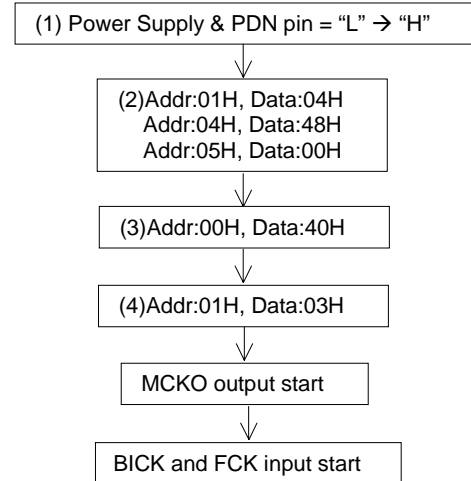

Figure 45. Clock Set Up Sequence (3)

## &lt;Example&gt;

- (1) After Power Up: PDN pin "L" → "H"  
"L" time (1) of 150ns or more is needed to reset the AK4631.
- (2) DIF1-0, PLL3-0, FS3-0, BCKO1-0, MSBS, BCKP and M/S bits should be set during this period.
- (3) Power Up VCOM: PMVCM bit = "0" → "1"  
VCOM should first be powered up before the other block operates.
- (4) Release the pull-down resistor of the MCKI pin: MCKPD bit = "1" → "0"
- (5) Enable MCKO output: MCKO bit = "1"
- (6) PLL starts after the PMPLL bit changes from "0" to "1" and PLL reference clock (MCKI pin) is supplied. PLL lock time is 40ms(max).
- (7) The normal clock is output from MCKO after PLL is locked.
- (8) The invalid frequency is output from MCKO during this period.
- (9) BICK and FCK clocks should be synchronized with MCKO clock.

## 4. EXT Slave Mode

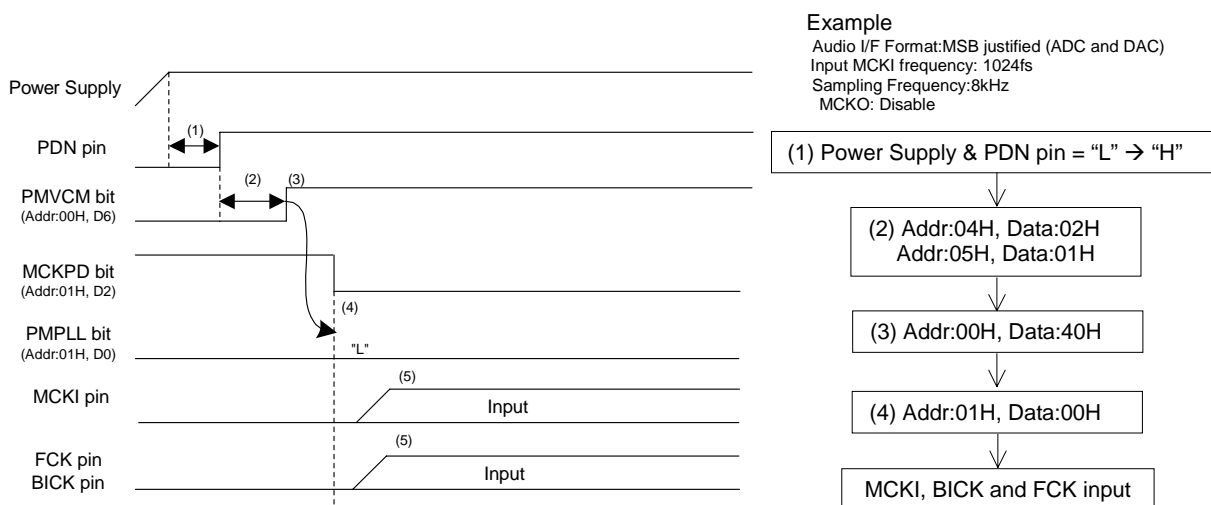

Figure 46. Clock Set Up Sequence (4)

## &lt;Example&gt;

- (1) After Power Up: PDN pin "L" → "H"  
 "L" time (1) of 150ns or more is needed to reset the AK4631.
- (2) DIF1-0 and FS1-0 bits should be set during this period.
- (3) Power Up VCOM: PMVCM bit = "0" → "1"  
 VCOM should first be powered up before the other block operates.
- (4) Release the pull-down resistor of the MCKI pin: MCKPD bit = "1" → "0"  
 Power down PLL: PMPLL bit = "0"
- (5) Normal operation starts after the MCKI, FCK and BICK are supplied.

## ■ MIC Input Recording

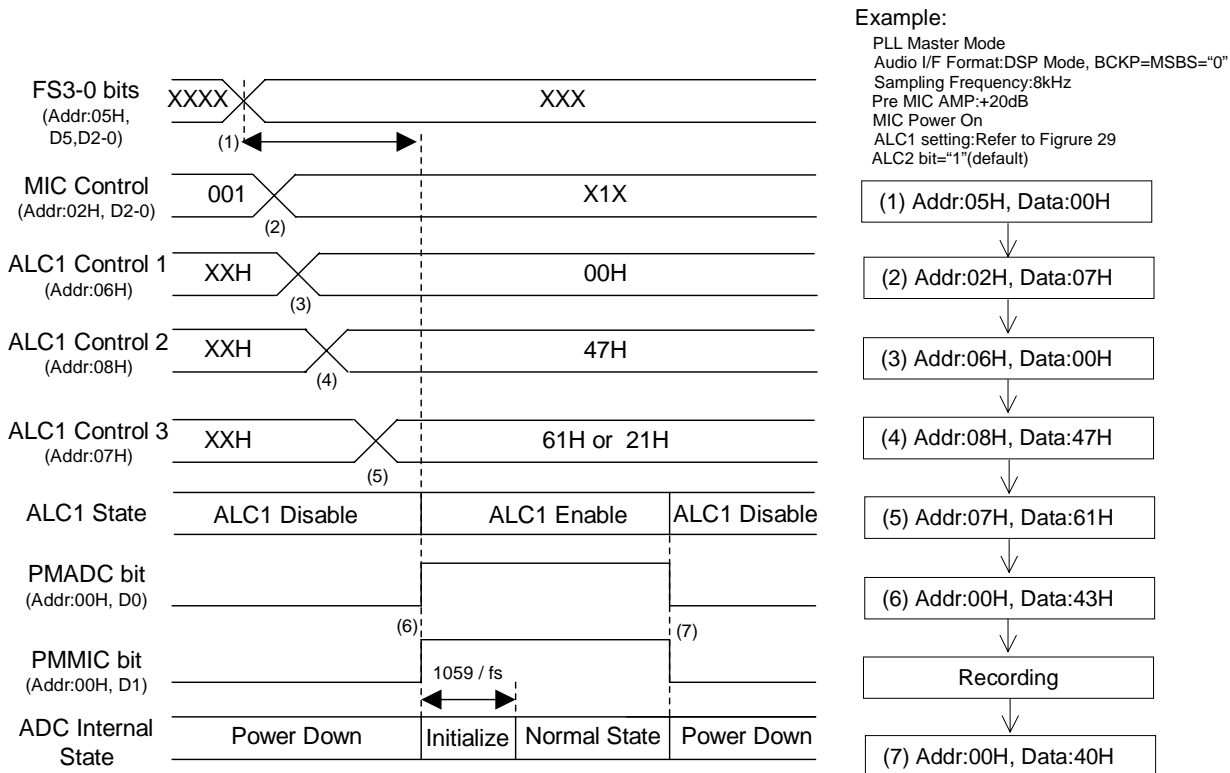

Figure 47. MIC Input Recording Sequence

### <Example>

This sequence is an example of ALC1 setting at  $s=8\text{kHz}$ . If the parameter of the ALC1 is changed, please refer to "Figure 30. Registers set-up sequence at the ALC1 operation"

At first, clocks should be supplied according to "Clock Set Up" sequence.

- (1) Set up a sampling frequency (FS3-0 bit). When the AK4631 is PLL mode, MIC and ADC should be powered-up in consideration of PLL lock time after a sampling frequency is changed.
- (2) Set up MIC input (Addr: 02H)
- (3) Set up Timer Select for ALC1 (Addr: 06H)
- (4) Set up REF value for ALC1 (Addr: 08H)
- (5) Set up LMTH, RATT, LMAT1-0 and ALC1 bits (Addr: 07H)
- (6) Power Up MIC and ADC: PMMIC bit = PMADC bit = "0" → "1"  
 The initialization cycle time of ADC is  $1059/\text{fs}=133\text{ms}@\text{fs}=8\text{kHz}$ .  
 After the ALC1 bit is set to "1" and MIC block is powered-up, the ALC1 operation starts from IPGA default value (0dB).
- (7) Power Down MIC and ADC: PMMIC bit = PMADC bit = "1" → "0"

When the registers for the ALC1 operation are not changed, ALC1 bit may be kept "1". The ALC1 operation is disabled because the MIC block is powered-down. If the registers for the ALC1 operation are also changed when the sampling frequency is changed, it should be done after the AK4631 goes to the manual mode (ALC1 bit = "0") or MIC block is powered-down (PMMIC bit = "0"). IPGA gain is reset when PMMIC bit is "0", and then IPGA operation starts from the default value when PMMIC bit is changed to "1".

## ■ Speaker-amp Output

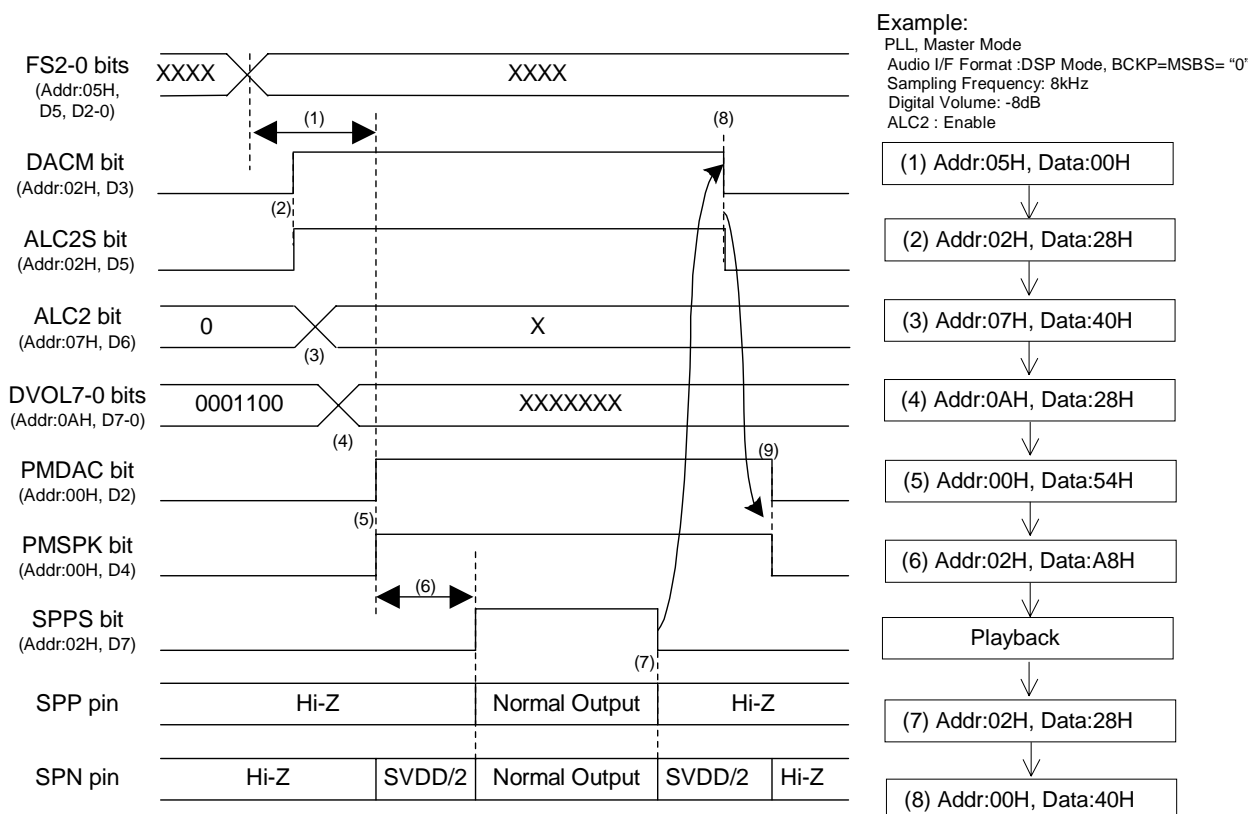

Figure 48. Speaker-Amp Output Sequence

### <Example>

At first, clocks should be supplied according to "Clock Set Up" sequence.

- (1) Set up a sampling frequency (FS3-0 bits). When the AK4631 is PLL mode, DAC and Speaker-Amp should be powered-up in consideration of PLL lock time after a sampling frequency is changed.
- (2) Set up the path of "DAC → SPK-Amp"  
 DACM = ALC2S bit: "0" → "1"
- (3) Set up the ALC2 Enable/Disable
- (4) Set up the digital volume (Addr: 0AH)  
 After DAC is powered-up, the digital volume changes from default value (0dB) to the register setting value by the soft transition.
- (5) Power Up of DAC and Speaker-Amp: PMDAC bit = PMSPK bit = "0" → "1"  
 When ALC2 bit = "1", the ALC2 is disabled (ALC2 gain is fixed to "-2dB") during the initialization cycle ( $512/f_s = 64\text{ms}$  @  $f_s=8\text{kHz}$ , ROTM bit = "0") and the ALC2 starts from "-2dB" after completing the initialization cycle.
- (6) Exit the power-save-mode of Speaker-Amp: SPPS bit = "0" → "1"  
 "(6)" time depends on the time constant of input impedance of the MIN pin and capacitor between the MIN pin and MOUT pin. If Speaker-Amp output is enabled before MIN-Amp (ALC2) becomes stable, pop noise may occur.  
 e.g. Input Impedance of the MIN pin =  $36\text{k}\Omega$  (max),  $C=0.1\mu\text{F}$ : Recommended wait time is more than  $5\tau = 18\text{ms}$ .
- (7) Enter the power-save-mode of Speaker-Amp: SPPS bit = "1" → "0"
- (8) Disable the path of "DAC → SPK-Amp"  
 DACM = ALC2S bit: "1" → "0"
- (9) Power Down DAC and Speaker-Amp: PMDAC bit = PMSPK bit = "1" → "0"

## ■ BEEP Signal Output from Speaker-Amp

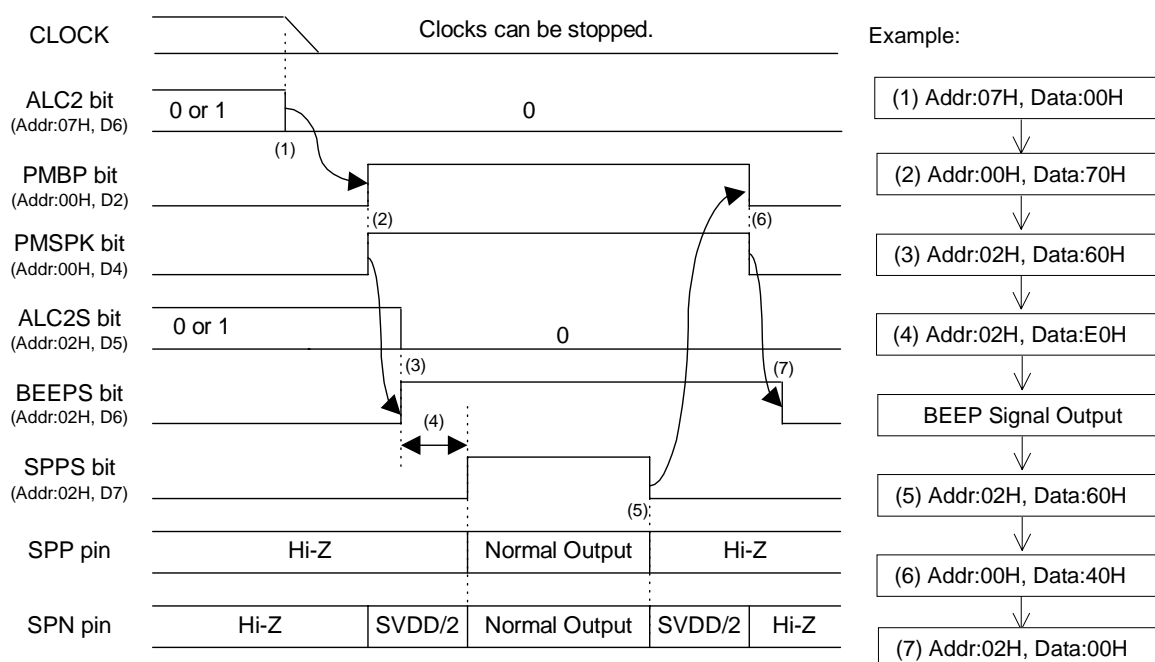

Figure 49. “BEEP-Amp → Speaker-Amp” Output Sequence

### <Example>

The clocks can be stopped when only BEEP-Amp and Speaker-Amp are operating. However ALC2 must be disabled.

- (1) ALC2 Disable: ALC2 bit = “0”
- (2) Power Up BEEP-Amp and Speaker-Amp: PMBP bit = PMSPK bit = “0” → “1”
- (3) Disable the path of “ALC2 → SPK-Amp”: ALC2S bit = “0”  
Enable the path of “BEEP → SPK-Amp”: BEEPS bit = “0” → “1”
- (4) Exit the power-save-mode of Speaker-Amp: SPPS bit = “0” → “1”  
“(4)” time depends on the time constant of external resistor and capacitor connected to the BEEP pin. If Speaker-Amp output is enabled before input of BEEP-Amp becomes stable, pop noise may occur.  
e.g. R=20k, C=0.1μF: Recommended wait time is more than  $5\tau = 10\text{ms}$ .
- (5) Enter the power-save-mode of Speaker-Amp: SPPS bit = “1” → “0”
- (6) Power Down BEEP-Amp and Speaker-Amp: PMBP bit = PMSPK bit = “1” → “0”
- (7) Disable the path of “BEEP → SPK-Amp”: BEEPS bit = “1” → “0”

## ■ Mono Lineout

1. In case of using an external mute circuit.(Compatible with AK4536/AK4630)

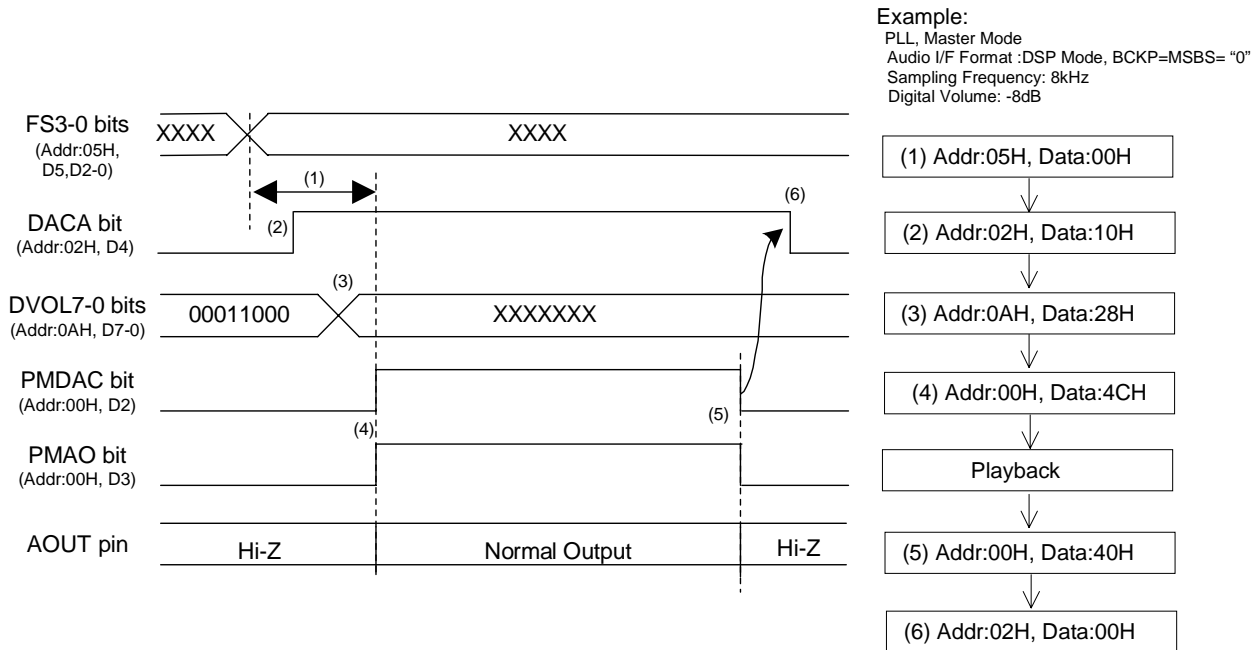

Figure 50. Mono Lineout Sequence

### <Example>

At first, clocks should be supplied according to "Clock Set Up" sequence.

- (1) Set up a sampling frequency (FS3-0 bits). When the AK4631 is PLL mode, DAC and Mono Line Amp should be powered-up in consideration of PLL lock time after a sampling frequency is changed.
- (2) Set up the path of "DAC → Mono Line Amp"  
 DACA bit: "0" → "1"
- (3) Set up the digital volume (Addr: 0AH)  
 After DAC is powered-up, the digital volume changes from default value (0dB) to the register setting value by the soft transition.
- (4) Power Up of DAC and Mono Line Amp: PMDAC bit = PMAO bit = "0" → "1"  
 When DAC and Mono Line Amp are powered-up, pop noise occurs from the AOUT pin. Therefore the AOUT pin should be muted by external circuit.
- (5) Power Down of DAC and Mono Line Amp: PMDAC bit = PMAO bit = "1" → "0"  
 When DAC and Mono Line Amp are powered-down, pop noise occurs from the AOUT pin. Therefore the AOUT pin should be muted by external circuit.
- (6) Disable the path of "DAC → Mono Line Amp"  
 DACA bit: "1" → "0"

## 2. In case of using POP reduction circuit of AK4631.

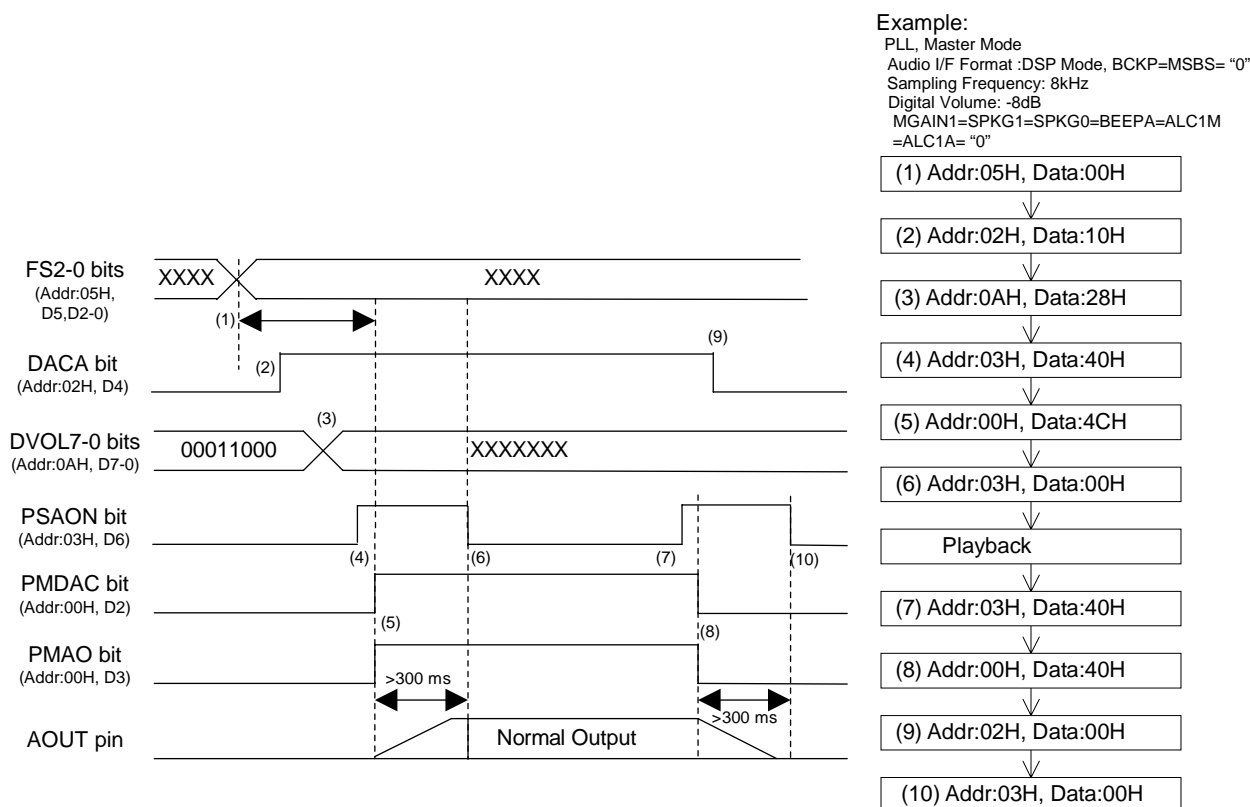

Figure 51. Mono Lineout Sequence

## &lt;Example&gt;

At first, clocks should be supplied according to "Clock Set Up" sequence.

- (1) Set up a sampling frequency (FS3-0 bits). When the AK4631 is PLL mode, DAC and Mono Line Amp should be powered-up in consideration of PLL lock time after a sampling frequency is changed.
- (2) Set up the path of "DAC → Mono Line Amp" : DACA bit: "0" → "1"
- (3) Set up the digital volume (Addr: 0AH)  
 After DAC is powered-up, the digital volume changes from default value (0dB) to the register setting value by the soft transition.
- (4) Enter power-save mode of Mono Line Amp: AOPSN bit = "0" → "1"
- (5) Power Up of DAC and Mono Line Amp: PMDAC bit = PMAO bit = "0" → "1"  
 AOUT pin rises up to VCOM voltage. Rise time is 200ms (max 300ms) at C=1μF.
- (6) Exit power-save mode of Mono Line Amp after AOUT pin rises up. : AOPSN bit = "1" → "0"  
 Mono Line Amp goes to normal operation.
- (7) Enter power-save mode of Mono Line Amp: AOPSN bit = "0" → "1"
- (8) Power Down of DAC and Mono Line Amp: PMDAC bit = PMAO bit = "1" → "0"  
 AOUT pin falls down to AVSS. Fall time is 200ms (max 300ms) at C=1μF.
- (9) Disable the path of "DAC → Mono Line Amp" : DACA bit: "1" → "0"
- (10) Exit power-save mode of Mono Line Amp after AOUT pin falls down. : AOPSN bit = "1" → "0"

## ■ Stop of Clock

Master clock can be stopped when ADC, DAC, ALC1, ALC2 and IPGA are not in operation.

### 1. In case of PLL Master Mode

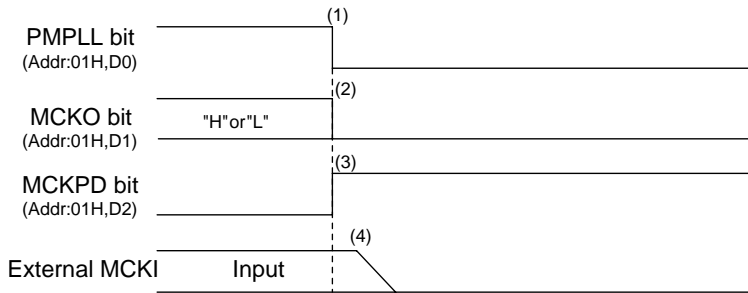
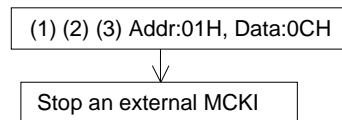

Figure 52. Clock Stopping Sequence (1)

#### Example:

Audio I/F Format: DSP Mode, BCKP = MSBS = "0"  
 BICK frequency at Master Mode : 64fs  
 Input Master Clock Select at PLL Mode : 11.2896MHz  
 Sampling Frequency:8kHz



#### <Example>

- (1) Power down PLL: PMPLL bit = "1" → "0"
- (2) Stop MCKO clock: MCKO bit = "1" → "0"
- (3) Pull down the MCKI pin: MCKPD bit = "0" → "1"

When the external master clock becomes Hi-Z, the MCKI pin should be pulled down.

- (4) Stop an external master clock.

### 2. When an external clocks (FCK or BICK pins) are used in PLL Slave Mode.

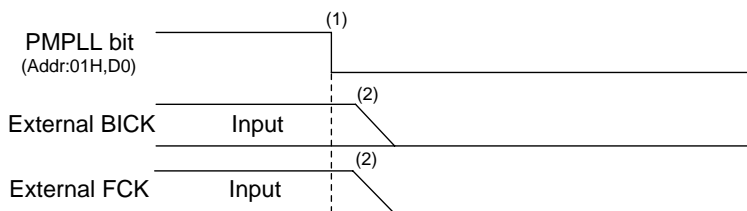
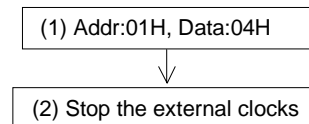

Figure 53. Clock Stopping Sequence (2)

#### Example

Audio I/F Format : DSP Mode, BCKP = MSBS = "0"  
 PLL Reference clock: BICK  
 BICK frequency: 64fs  
 Sampling Frequency: 8kHz



#### <Example>

- (1) Power down PLL: PMPLL bit = "1" → "0"
- (2) Stop the external BICK and FCK clocks

### 3. When an external clock (MCKI pin) is used in PLL Slave Mode.

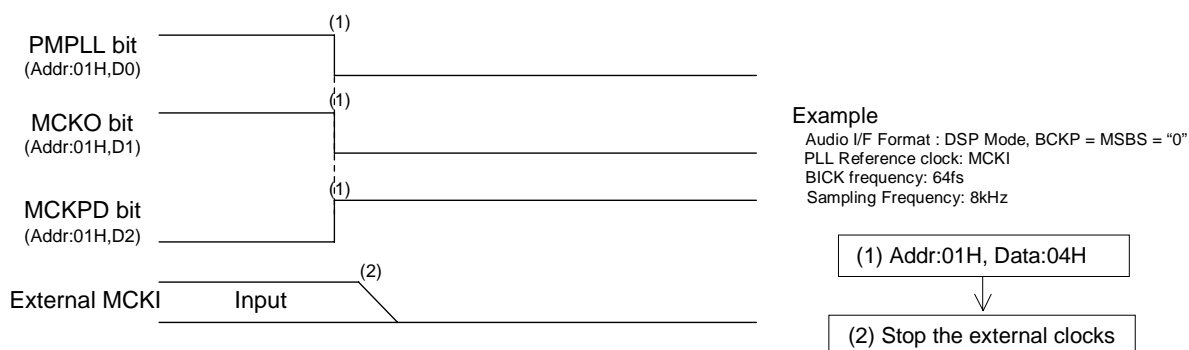

Figure 54. Clock Stopping Sequence (3)

#### <Example>

- (1) Power down PLL: PMPLL bit = "1" → "0"  
 Stop MCKO output: MCKO bit = "1" → "0"  
 Pull down the MCKI pin: MCKPD bit = "0" → "1"  
 When the external master clock becomes Hi-Z, the MCKI pin should be pulled down.
- (2) Stop the external master clock.

### 4. EXT Slave Mode

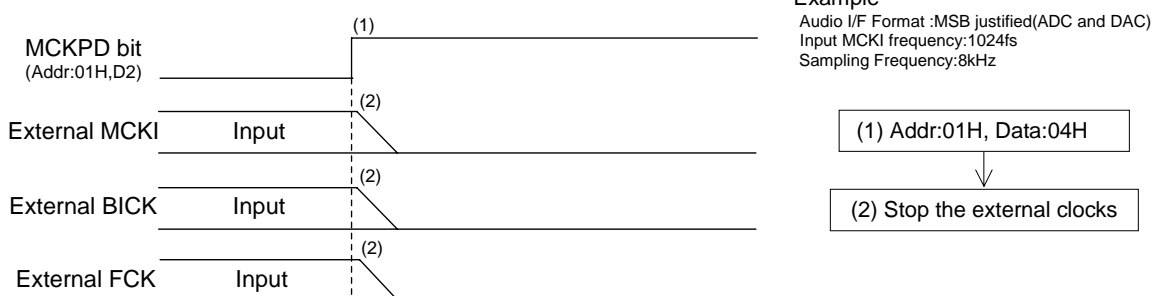

Figure 55. Clock Stopping Sequence (4)

#### <Example>

- (1) Pull down the MCKI pin: MCKPD bit = "0" → "1"  
 When the external master clock becomes Hi-Z, the MCKI pin should be pulled down.
- (2) Stop the external MCKI, BICK and FCK clocks.

## ■ Power Down

If the clocks are supplied, power down VCOM (PMVCM bit: "1" → "0") after all blocks except for VCOM are powered-down and the master clock stops. The AK4631 is also powered-down by the PDN pin = "L". When the PDN pin = "L", the registers are initialized.

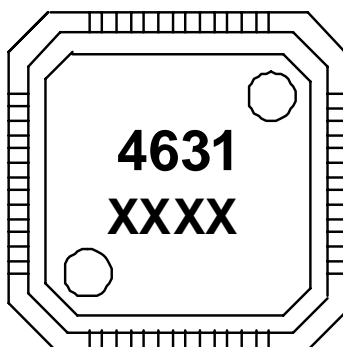

**MARKING**

1

XXXX: Date code identifier (4 digits)

**REVISION HISTORY**

Date (YY/MM/DD)	Revision	Reason	Page	Contents
04/06/15	00	First Edition		
04/11/19	01	Addition of explanation	4-6	Some explanation of "Compare with AK4536 and AK4630 are added"
			8	Recommended Operating Conditions : Note 6 is added for Speaker-Amp. "Note 6. SVDD = 2.6 ~ 3.6V when 8Ω dynamic speaker is connected to the AK4631."
08/12/12	02	Specification Change	68	PACKAGE Package drawing was changed.
			69	MARKING Marking drawing was changed.

IMPORTANT NOTICE

- These products and their specifications are subject to change without notice.  
When you consider any use or application of these products, please make inquiries the sales office of Asahi Kasei EMD Corporation (AKEMD) or authorized distributors as to current status of the products.
- AKEMD assumes no liability for infringement of any patent, intellectual property, or other rights in the application or use of any information contained herein.
- Any export of these products, or devices or systems containing them, may require an export license or other official approval under the law and regulations of the country of export pertaining to customs and tariffs, currency exchange, or strategic materials.
- AKEMD products are neither intended nor authorized for use as critical components<sub>Note1</sub> in any safety, life support, or other hazard related device or system<sub>Note2</sub>, and AKEMD assumes no responsibility for such use, except for the use approved with the express written consent by Representative Director of AKEMD. As used here:
  - Note1) A critical component is one whose failure to function or perform may reasonably be expected to result, whether directly or indirectly, in the loss of the safety or effectiveness of the device or system containing it, and which must therefore meet very high standards of performance and reliability.
  - Note2) A hazard related device or system is one designed or intended for life support or maintenance of safety or for applications in medicine, aerospace, nuclear energy, or other fields, in which its failure to function or perform may reasonably be expected to result in loss of life or in significant injury or damage to person or property.
- It is the responsibility of the buyer or distributor of AKEMD products, who distributes, disposes of, or otherwise places the product with a third party, to notify such third party in advance of the above content and conditions, and the buyer or distributor agrees to assume any and all responsibility and liability for and hold AKEMD harmless from any and all claims arising from the use of said product in the absence of such notification.