



AKD4645A-A

Evaluation board Rev.1 for AK4645A

GENERAL DESCRIPTION

AKD4645A is an evaluation board for the AK4645A, stereo CODEC with built-in MIC/HP amplifier. The AKD4645A can evaluate A/D converter and D/A converter separately in addition to loopback mode (A/D → D/A). The AKD4645A also has the digital audio interface and can achieve the interface with digital audio systems via opt-conector.

■ **Ordering guide**

AKD4645A --- Evaluation board for AK4645A
 (Cable for connecting with printer port of IBM-AT, compatible PC and control software are packed with this. This control software does not support Windows NT.)

FUNCTION

- DIT/DIR with optical input/output
- BNC connector for an external clock input
- 10pin Header for serial control mode

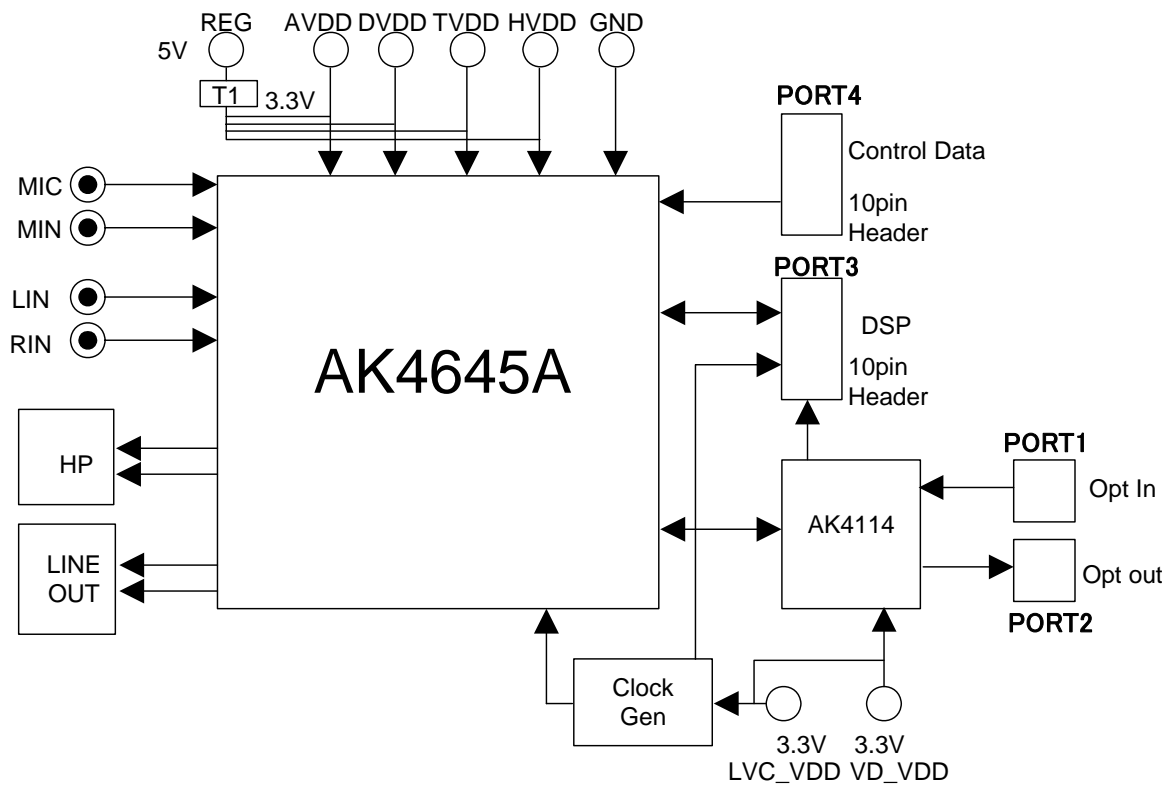

Figure 1. AKD4645A Block Diagram

* Circuit diagram and PCB layout are attached at the end of this manual

Board Outline Chart

■ Outline Chart

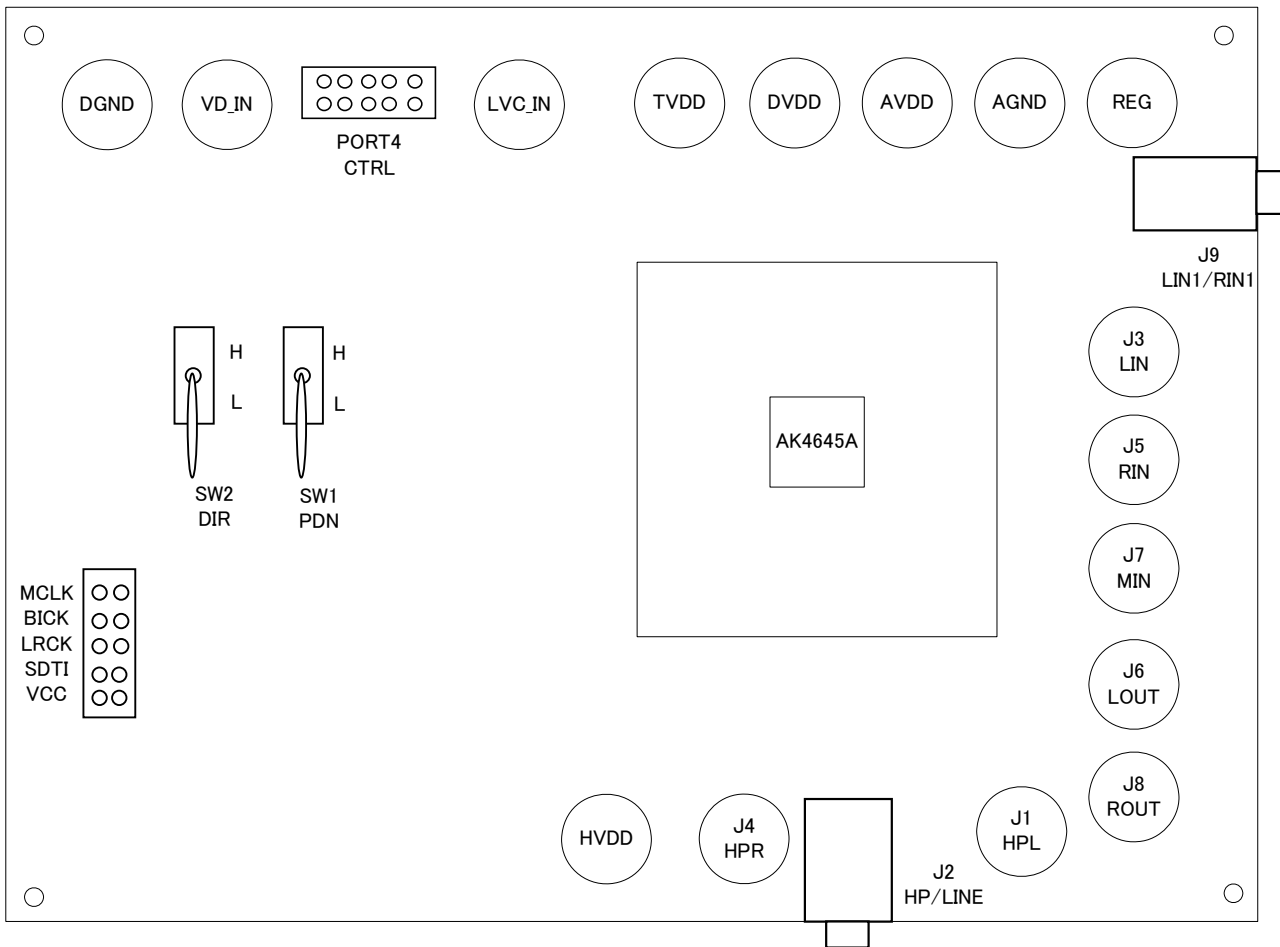

Figure 2. AKD4645A Outline Chart

■ Operation sequence

1) Set up the power supply lines.

[AVDD] (orange)	= 2.6 ~ 3.6V	: for AVDD of AK4645A (typ. 3.3V)
[HVDD] (orange)	= 2.6 ~ 5.25V	: for HVDD of AK4645A (typ. 3.3/5.0V)
[DVDD] (orange)	= 2.6 ~ 3.6V	: for DVDD of AK4645A (typ. 3.3V:=AVDD±0.3V)
[TVDD] (orange)	= 1.6 ~ 3.6V	: for TVDD of AK4645A (typ. 3.3V:≤DVDD)
[LVC_IN] (orange)	= 1.6 ~ 3.6V	: for logic (typ. 3.3V:=TVDD)
[VD_IN] (orange)	= 2.7 ~ 3.6V	: for AK4114 and logic (typ. 3.3V)
[REG] (red)	= 5.0V	: for regulator (typ. 5.0V)
[AGND] (black)	= 0V	: for analog ground
[DGND] (black)	= 0V	: for logic ground

Each supply line should be distributed from the power supply unit.

2) Set up the evaluation mode, jumper pins and DIP switches. (See the followings.)

3) Power on.

The AK4645A and AK4114 should be reset once bringing SW1 and SW2 “L” upon power-up.

■ Evaluation mode

(1) External Slave Mode

In case of AK4645A evaluation using AK4114, it is necessary to correspond to audio interface format for AK4645A and AK4114. About AK4645A’s audio interface format, refer to datasheet of AK4645A. About AK4114’s audio interface format, refer to **Table 1** in this manual.

- (1-1) Evaluation of Recording block (MIC, ADC) using DIT of AK4114 <default>
- (1-2) Evaluation of Playback block (HP, LINEOUT) using DIR of AK4114
- (1-3) Evaluation of Loop-back using AK4114
- (1-4) All interface signals including master clock are fed externally.

(1-1) Evaluation of Recording block (MIC, ADC) using DIT of AK4114 <default>

PORT2 (DIT) and X1 (X’tal) are used. DIT generates audio bi-phase signal from received data and which is output through optical connector (TOTX141). Nothing should be connected to PORT1 (DIR) and PORT3 (DSP) and J11 (EXT). The jumper pins should be set to the following.

JP name	State	JP name	State
JP25(EXT)	Short	JP32(BICK_SEL)	Short
JP26(4114_MCKI_IN)	Open	JP33(LRCK_SEL)	Short
JP27(4114BICK_SEL)	Open	JP35(LRCK_MODE)	Open
JP28(4114LRCK_SEL)	Open	JP36(BICK_MODE)	Open



When AK4114 is used, JP22 (MKFS) and JP23 (BCFS) are not used. Therefore, JP22 (MKFS) should be set to “x1” and JP23 (BCFS) should be set to “64fs”.

* The AK4114 operates at fs of 32kHz or more. If the fs is slower than 32kHz, this evaluation mode can’t be used.

(1-2) Evaluation of Playback block (HP, LINEOUT) using DIR of AK4114

PORT1 (DIR) is used. Nothing should be connected to PORT2 (DIT), PORT3 (DSP) and J11 (EXT). The jumper pins should be set to the following.

JP name	State	JP name	State
JP25(EXT)	Short	JP32(BICK_SEL)	Short
JP26(4114_MCKI_IN)	Open	JP33(LRCK_SEL)	Short
JP27(4114BICK_SEL)	Open	JP35(LRCK_MODE)	Open
JP28(4114LRCK_SEL)	Open	JP36(BICK_MODE)	Open



When AK4114 is used, JP22 (MKFS) and JP23 (BCFS) are not used. Therefore, JP22 (MKFS) should be set to “x1” and JP23 (BCFS) should be set to “64fs”.

* The AK4114 operates at fs of 32kHz or more. If the fs is slower than 32kHz, this evaluation mode can't be used.

(1-3) Evaluation of Loop-back using AK4114

X'tal oscillator (X1) is used. Nothing should be connected to PORT1 (DIR), PORT3 (DSP) and J11 (EXT). The jumper pins should be set to the following.

JP name	State	JP name	State
JP25(EXT)	Short	JP32(BICK_SEL)	Short
JP26(4114_MCKI_IN)	Open	JP33(LRCK_SEL)	Short
JP27(4114BICK_SEL)	Open	JP35(LRCK_MODE)	Open
JP28(4114LRCK_SEL)	Open	JP36(BICK_MODE)	Open



When AK4114 is used, JP22 (MKFS) and JP23 (BCFS) are not used. Therefore, JP22 (MKFS) should be set to “x1” and JP23 (BCFS) should be set to “64fs”.

* The AK4114 operates at fs of 32kHz or more. If the fs is slower than 32kHz, this evaluation mode can't be used.

(1-4) All interface signals including master clock are fed externally.

PORT3 (ROM) is used. Nothing should be connected to PORT1 (DIR), PORT2 (DIT), and J11 (EXT). The jumper pins should be set to the following. Please set SW2= “L”

JP name	State	JP name	State
JP25(EXT)	Short	JP32(BICK_SEL)	Short
JP26(4114_MCKI_IN)	Open	JP33(LRCK_SEL)	Short
JP27(4114BICK_SEL)	Open	JP35(LRCK_MODE)	Open
JP28(4114LRCK_SEL)	Open	JP36(BICK_MODE)	Open

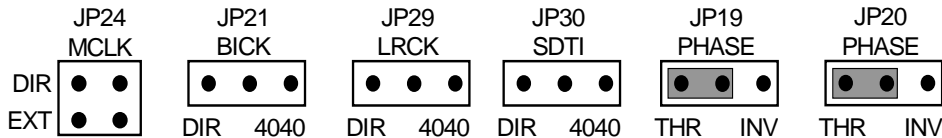

When AK4114 is used, JP22 (MKFS) and JP23 (BCFS) are not used. Therefore, JP22 (MKFS) should be set to “x1” and JP23 (BCFS) should be set to “64fs”.

JP20 (PHASE) is jumper which decides polarity of BICK, “THR” or “INV” should be selected according to the audio interface format.

■ DIP Switch set up

[S1] : Mode Setting of AK4114 and AK4645A
ON is “H”, OFF is “L”.

No.	Name	ON (“H”)	OFF (“L”)	default
1	DIF0	AK4114 Audio Format Setting See Table 2		OFF
2	DIF1			OFF
3	DIF2			ON
4	OCKS1	AK4114 Master Clock Setting See Table 3		OFF
5	CAD0			OFF
6	I2C	See Table 4		OFF

Table 1. Mode Setting for AK4645A and AK4114

DIF2	DIF1	DIF0	AK4114DAUX	AK4114SDTO	LRCK		BICK	
						I/O		I/O
0	0	0	24bit, Left justified	16bit, Right justified	H/L	O	64fs	O
0	0	1	24bit, Left justified	18bit, Right justified	H/L	O	64fs	O
0	1	0	24bit, Left justified	20bit, Right justified	H/L	O	64fs	O
0	1	1	24bit, Left justified	24bit, Right justified	H/L	O	64fs	O
1	0	0	24bit, Left justified	24bit, Left justified	H/L	O	64fs	O
1	0	1	24bit, I ² S	24bit, I ² S	L/H	O	64fs	O
1	1	0	24bit, Left justified	24bit, Left justified	H/L	I	64-128fs	I
1	1	1	24bit, I ² S	24bit, I ² S	L/H	I	64-128fs	I

<default>

Table 2. Setting for AK4114 Audio Interface Format

OCKS1	X'tal	
0	256fs	<default>
1	512fs	

Table 3. AK4114 Master Clock Setting

■ Other jumper pins set up

- [JP1] (GND) : Analog ground and Digital ground
 OPEN : Separated.
 SHORT : Common. (The connector “DGND” can be open.) <default>
- [JP2] : Selection of MIN path or LIN3 path
 MIN : MIN path (**AIN3 bit=“0”** : Register Address 21H)
 LIN3 : LIN3 path (**AIN3 bit=“1”** : Register Address 21H)
- [JP5, 4] : Selection of using MIC-power supply for L/RIN1 path
 SHORT : MIC-power is supplied.
 OPEN : MIC-power is not supplied. <default>
- [JP3,6,7,8] : power AVDD,DVDD,HVDD,TVDD
 short : for regulator (typ. 5.0V)<default>
 open : Separated.
- [JP11] (HPL) : Analog Output
 BNC: Output from J1. <default>
 HP: Output from J2.
- [JP12] (LIN-SEL): Analog Input
 LIN2: LIN2 Input.<default>
 LIN3: LIN3 Input.
 LIN4: LIN4 Input.
- [JP13] (HPR) : Analog Output
 BNC: Output from J4. <default>
 HP: Output from J2.
- [JP14] (RIN-SEL): Analog Input
 LIN2 : RIN2 Input.<default>
 LIN3: RIN3 Input.
 LIN4: RIN4 Input
- [JP15] (LOUT-SEL) : Analog Output
 BNC: Output from J6. <default>
 Mini-Jack: Output from J2.
- [JP16] (ROUT-SEL) : Analog Output
 BNC: Output from J8<default>
 Mini-Jack: Output from J2.
- [JP22] (MKFS) : MCLK Frequency
 x1 : 256fs <default>
 x2 : 512fs
 x4 : 1024fs
- [JP23] (BCFS) : BICK Frequency
 32fs : 32fs frequency
 64fs : 64fs frequency <default>

[JP31] (MODE_SEL) : Serial Control Interface
3-WIRE : 3-WIRE Serial Control Mode <default>
I2C : I²C-bus Control Mode

[JP34] (DAUX_SEL): Presence of external device connection via PORT3(DSP)
SHORT : connection
OPEN : non-connection <default>

■ The function of the toggle SW

[SW1] (PDN): Power down of AK4645A. Keep “H” during normal operation.

[SW2] (DIR): Power down of AK4114. Keep “H” during normal operation.
Keep “L” when AK4114 is not used.

■ Indication for LED

[LED1] (ERF): Monitor INT0 pin of the AK4114. LED turns on when some error has occurred to AK4114.

■ **Serial Control**

The AK4645A can be controlled via the printer port (parallel port) of IBM-AT compatible PC. Connect PORT4 (CTRL) with PC by 10 wire flat cable packed with the AKD4645A. Table 4 shows switch and jumper settings for serial control.

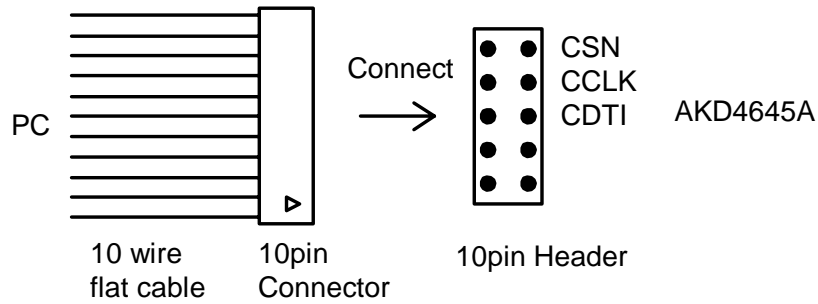

Figure 3. Connect of 10 wire flat cable

Mode	S1	
	I2C	CAD0
3-WIRE	OFF	OFF
I2C	CAD0=0	ON
	CAD0=1	ON

Table 4. Serial Control Setting

■ Analog Input/Output Circuits

(1) Input Circuits

(1-1) LIN1/RIN1, LIN2/RIN2, LIN3/RIN3, LIN4/RIN4 Input Circuit

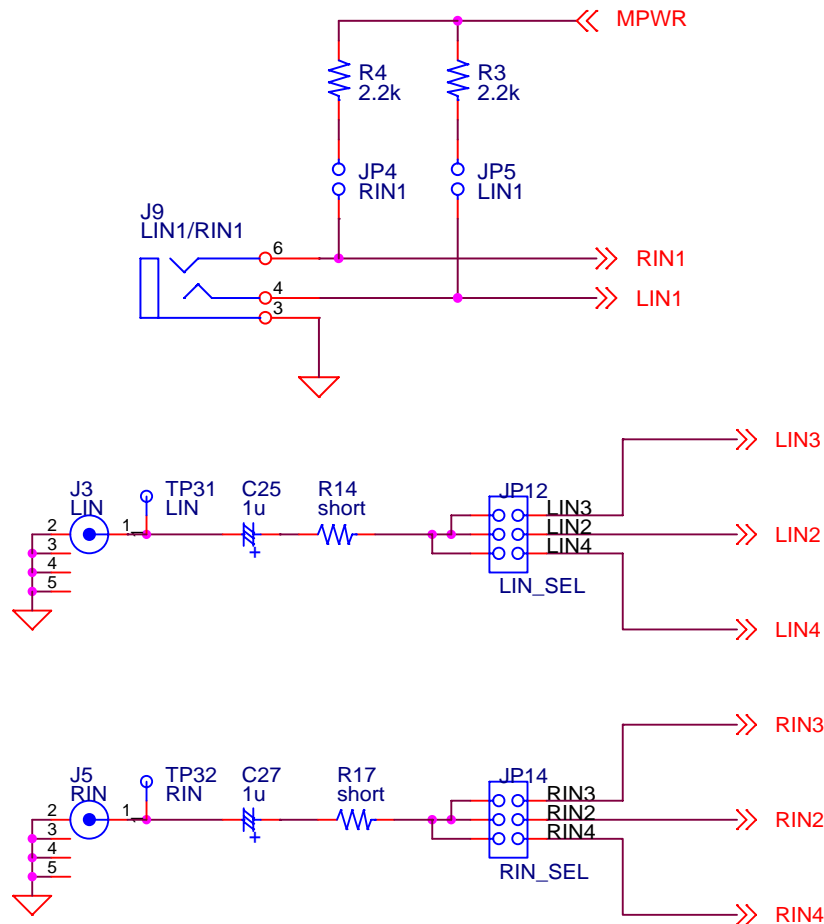
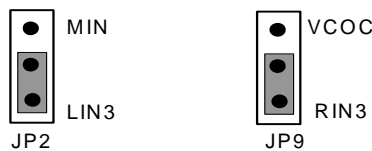

Figure 4. LIN1/RIN1, LIN2/RIN2, LIN3/RIN3, LIN4/RIN4 Input Circuit

LIN2/RIN2, LIN3/RIN3, LIN4/RIN4 shares J3/J5.
 JP12(LIN_SEL) and JP14(RIN_SEL) select each path.

When LIN3/RIN3 paths of AK4645A are used, JP2 and JP9 should be set as below.
AIN3bit = "1" (Register Address 21H)



When microphone is connected to J9, JP4 and JP5 should be short.

(1-2) MIN Input Curcuits

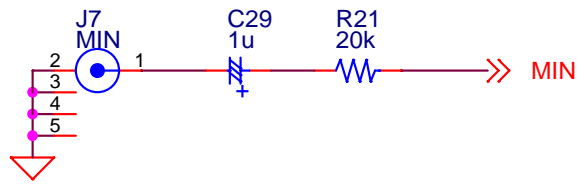
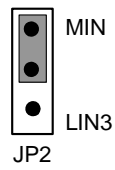

Figure 5 . MIN Input Circuit

When MIN Input path of AK4645A is used, JP2 should be set as below.
AIN3bit =“0” (Register Address 21H)



(2) Output Circuits

(2-1) HP Output Circuit

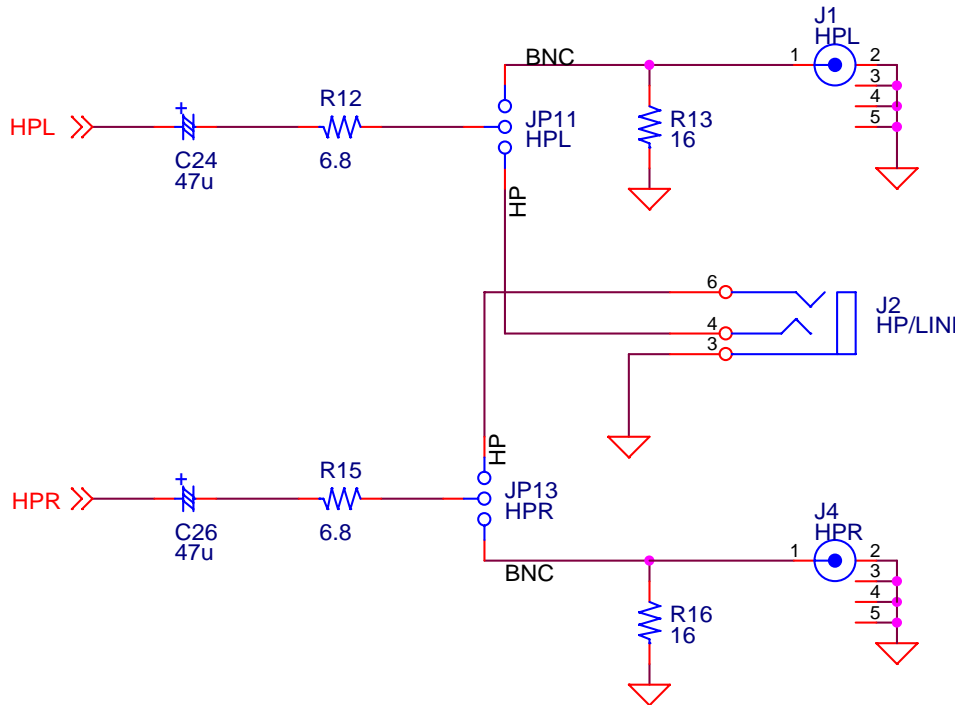
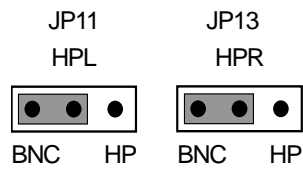
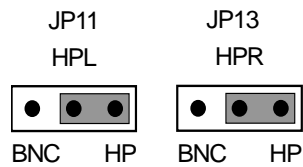

Figure 6 . HP Output Circuit

(2-1-1) In case that signal is output from J1 and J4.



(2-1-2) In case that signal is output from J2.



(2-2) LOUT/ROUT(LOP/LON) Output Circuit

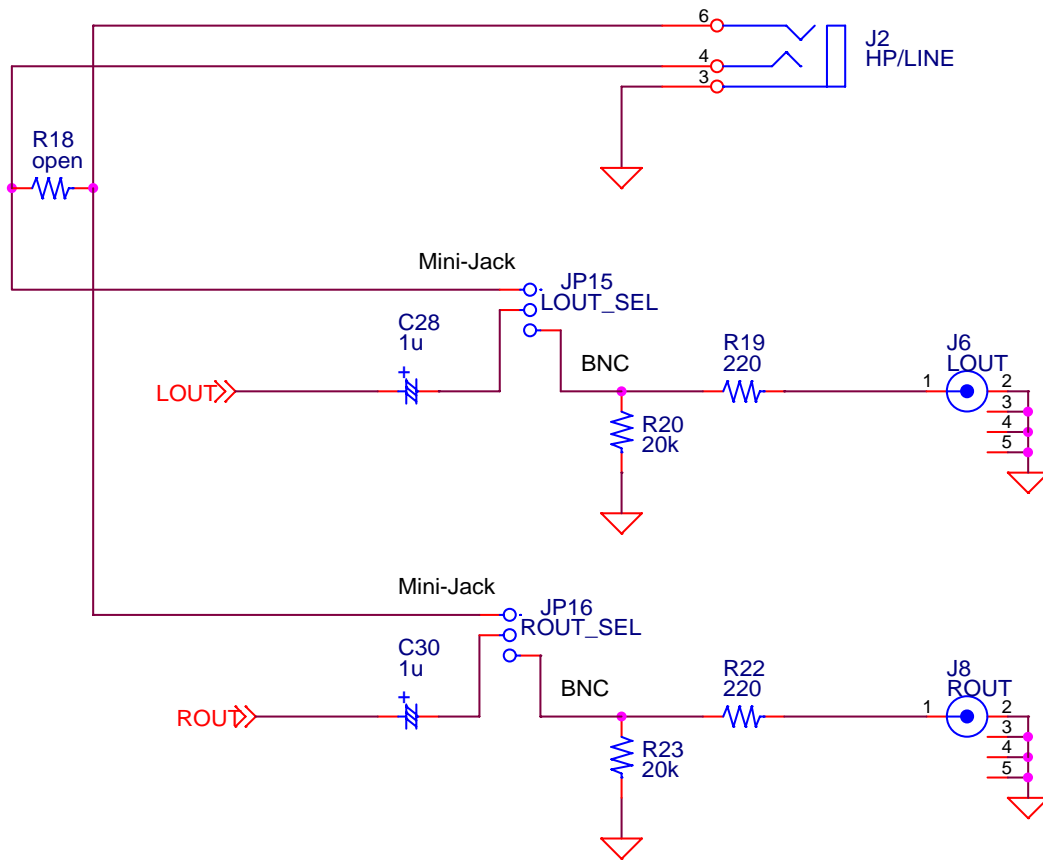
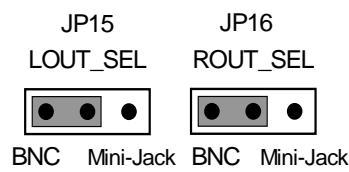
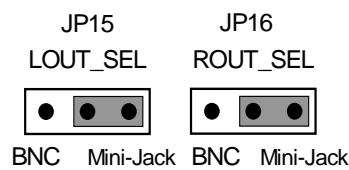

Figure 7 . LOUT/ROUT(LOP/LON) Output Circuit

(2-1-1) In case that signal is output from J6 and J8.



(2-1-1) In case that signal is output from J2.



* AKM assumes no responsibility for the trouble when using the above circuit examples.

Control Software Manual

■ Set-up of evaluation board and control software

1. Set up the AKD4645A-A according to previous term.
2. Connect IBM-AT compatible PC with AKD4645A-A by 10-line type flat cable (packed with AKD4645A-A). Take care of the direction of 10pin header. (Please install the driver in the CD-ROM when this control software is used on Windows 2000/XP. Please refer “Installation Manual of Control Software Driver by AKM device control software”. In case of Windows95/98/ME, this installation is not needed. This control software does not operate on Windows NT.)
3. Insert the CD-ROM labeled “AK4645A-A Evaluation Kit” into the CD-ROM drive.
4. Access the CD-ROM drive and double-click the icon of “AKD4645A.exe” to set up the control program.
5. Then please evaluate according to the follows.

■ Operation flow

Keep the following flow.

1. Set up the control program according to explanation above.
2. Click “Port Reset” button.

■ Explanation of each buttons

[Port Reset]	Set up the USB interface board (AKDUSBIF-A) .
[Write default] :	Initialize the register of AK4645A.
[All Write] :	Write all registers that is currently displayed.
[Function1] :	Dialog to write data by keyboard operation.
[Function2] :	Dialog to write data by keyboard operation.
[Function3] :	The sequence of register setting can be set and executed.
[Function4] :	The sequence that is created on [Function3] can be assigned to buttons and executed.
[Function5]:	The register setting that is created by [SAVE] function on main window can be assigned to buttons and executed.
[SAVE] :	Save the current register setting.
[OPEN] :	Write the saved values to all register.
[Write] :	Dialog to write data by mouse operation.
[Filter] :	Set Programmable Filter (FIL1, FIL3, EQ) of AK4645A easily.

■ Indication of data

Input data is indicated on the register map. Red letter indicates “H” or “1” and blue one indicates “L” or “0”. Blank is the part that is not defined in the datasheet.

■ Explanation of each dialog

1. [Write Dialog]: Dialog to write data by mouse operation

There are dialogs corresponding to each register.

Click the [Write] button corresponding to each register to set up the dialog. If you check the check box, data becomes "H" or "1". If not, "L" or "0".

If you want to write the input data to AK4645A, click [OK] button. If not, click [Cancel] button.

2. [Function1 Dialog] : Dialog to write data by keyboard operation

Address Box: Input registers address in 2 figures of hexadecimal.

Data Box: Input registers data in 2 figures of hexadecimal.

If you want to write the input data to AK4645A, click [OK] button. If not, click [Cancel] button.

3. [Function2 Dialog] : Dialog to evaluate IVOL and DVOL

Address Box: Input registers address in 2 figures of hexadecimal.

Start Data Box: Input starts data in 2 figures of hexadecimal.

End Data Box: Input end data in 2 figures of hexadecimal.

Interval Box: Data is written to AK4645A by this interval.

Step Box: Data changes by this step.

Mode Select Box:

If you check this check box, data reaches end data, and returns to start data.

[Example] Start Data = 00, End Data = 09

Data flow: 00 01 02 03 04 05 06 07 08 09 09 08 07 06 05 04 03 02 01 00

If you do not check this check box, data reaches end data, but does not return to start data.

[Example] Start Data = 00, End Data = 09

Data flow: 00 01 02 03 04 05 06 07 08 09

If you want to write the input data to AK4645A, click [OK] button. If not, click [Cancel] button.

4. [Save] and [Open]

4-1. [Save]

Save the current register setting data. The extension of file name is “akr”.

(Operation flow)

- (1) Click [Save] Button.
- (2) Set the file name and push [Save] Button. The extension of file name is “akr”.

4-2. [Open]

The register setting data saved by [Save] is written to AK4645A. The file type is the same as [Save].

(Operation flow)

- (1) Click [Open] Button.
- (2) Select the file (*.akr) and Click [Open] Button.

5. [Function3 Dialog]

The sequence of register setting can be set and executed.

(1) Click [F3] Button.

(2) Set the control sequence.

Set the address, Data and Interval time. Set “-1” to the address of the step where the sequence should be paused.

(3) Click [Start] button. Then this sequence is executed.

The sequence is paused at the step of Interval="-1". Click [START] button, the sequence restarts from the paused step.

This sequence can be saved and opened by [Save] and [Open] button on the Function3 window. The extension of file name is “aks”.

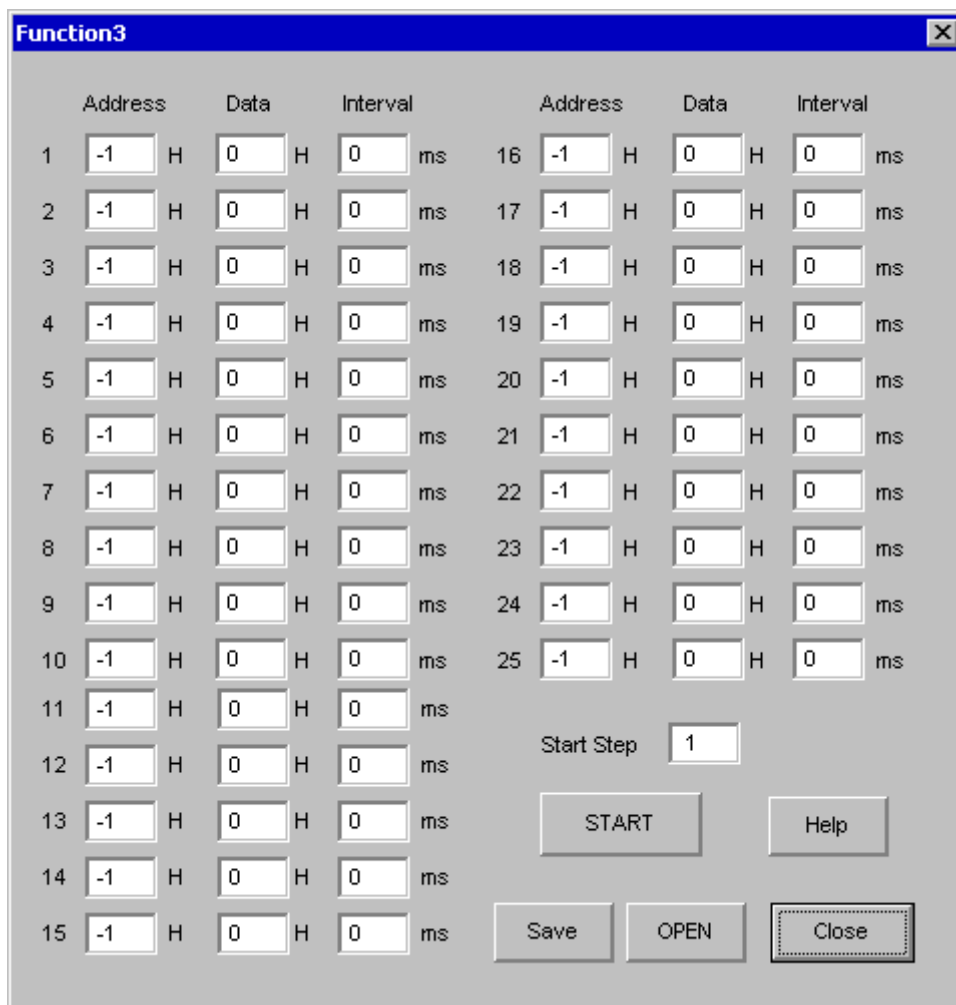

Figure 8. Window of [F3]

6. [Function4 Dialog]

The sequence that is created on [Function3] can be assigned to buttons and executed. When [F4] button is clicked, the window as shown in Figure 9 opens.

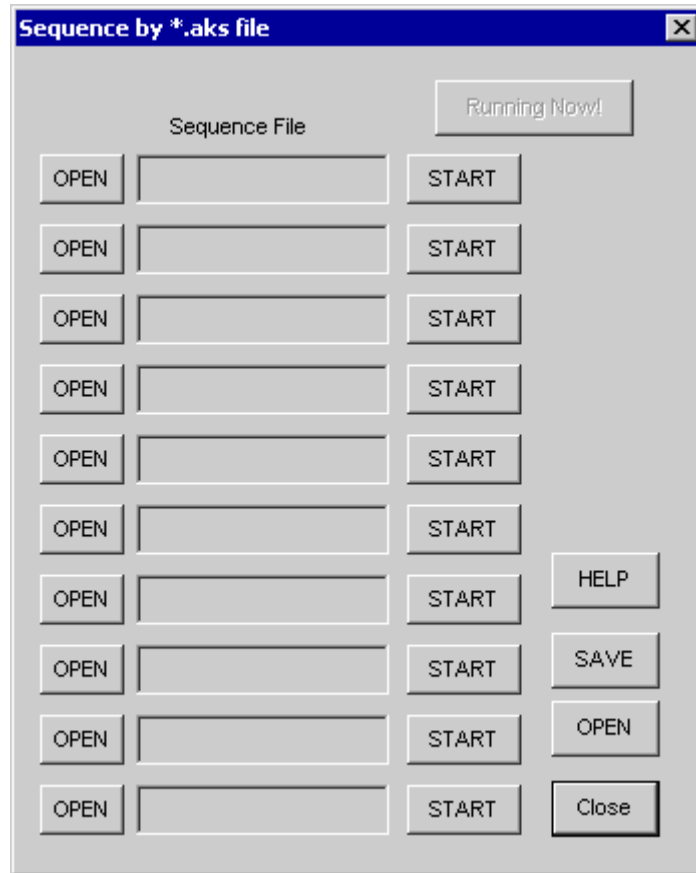

Figure 9. [F4] window

6-1. [OPEN] buttons on left side and [START] buttons

(1) Click [OPEN] button and select the sequence file (*.aks).

The sequence file name is displayed as shown in Figure 10.

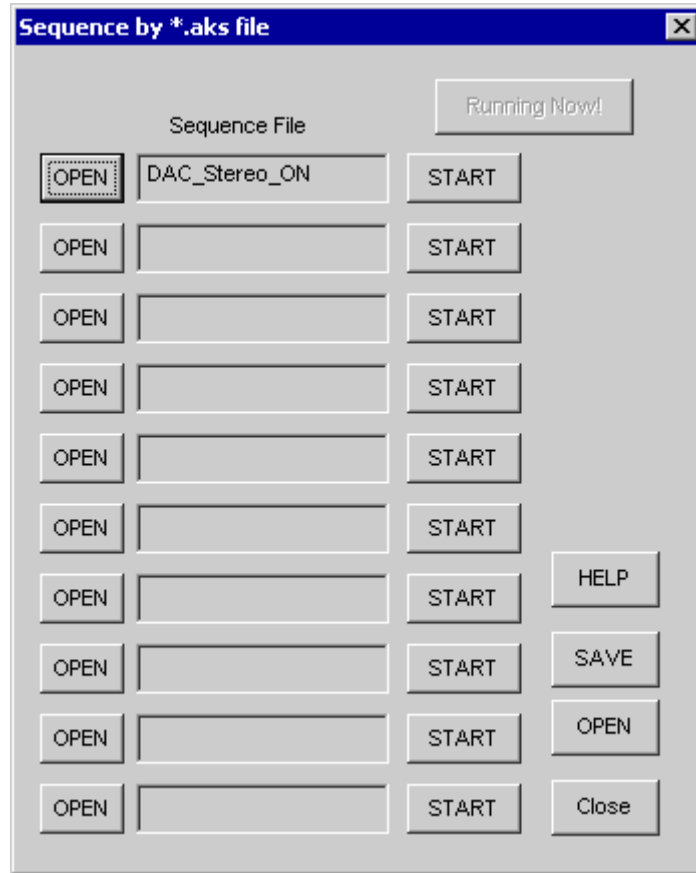

Figure 10. [F4] window(2)

(2) Click [START] button, then the sequence is executed.

3-2. [SAVE] and [OPEN] buttons on right side

[SAVE] : The sequence file names can assign be saved. The file name is *.ak4.

[OPEN] : The sequence file names assign that are saved in *.ak4 are loaded.

3-3. Note

(1) This function doesn't support the pause function of sequence function.

(2) All files need to be in same folder used by [SAVE] and [OPEN] function on right side.

(3) When the sequence is changed in [Function3], the file should be loaded again in order to reflect the change.

7. [Function5 Dialog]

The register setting that is created by [SAVE] function on main window can be assigned to buttons and executed. When [F5] button is clicked, the following window as shown in Figure 11 opens.

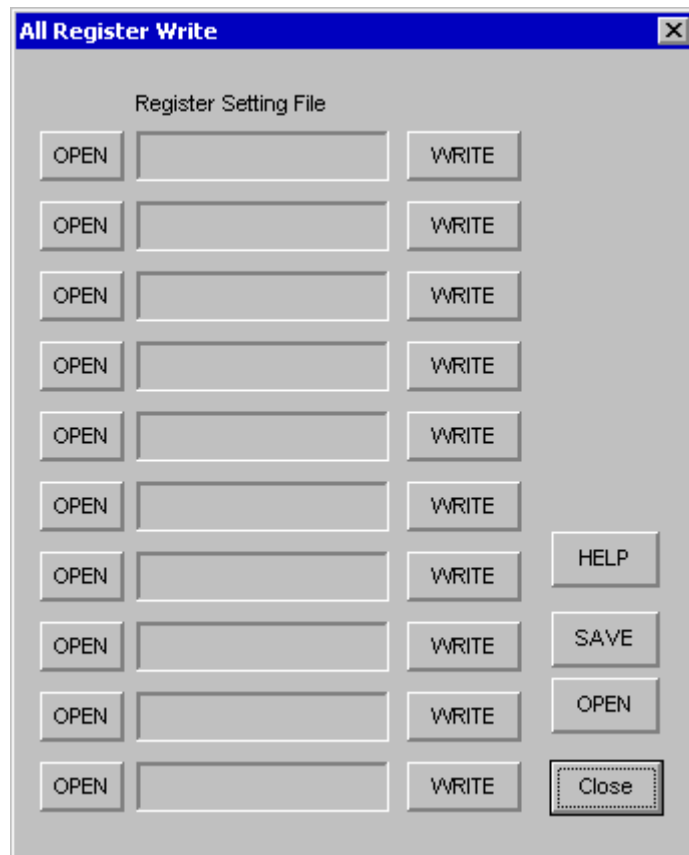

Figure 11. [F5] window

7-1. [OPEN] buttons on left side and [WRITE] button

(1) Click [OPEN] button and select the register setting file (*.akr).

The register setting file name is displayed as shown in Figure 12.

(2) Click [WRITE] button, then the register setting is executed.

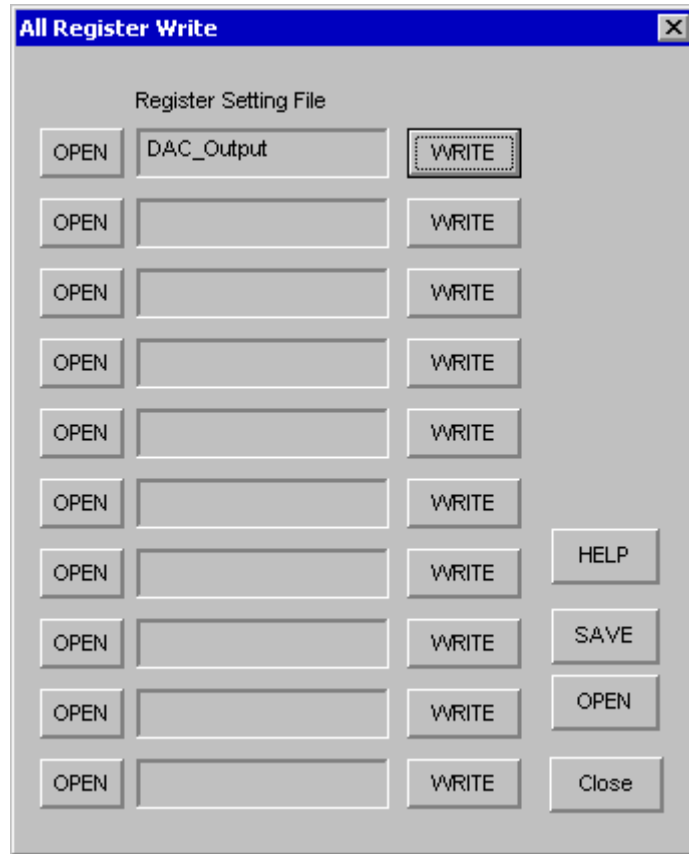

Figure 12. [F5] windows(2)

7-2. [SAVE] and [OPEN] buttons on right side

[SAVE] : The register setting file names assign can be saved. The file name is *.ak5.

[OPEN] : The register setting file names assign that are saved in *.ak5 are loaded.

7-3. Note

(1) All files need to be in same folder used by [SAVE] and [OPEN] function on right side.

(2) When the register setting is changed by [Save] Button in main window, the file should be loaded again in order to reflect the change.

8. [Filter Dialog]

This dialog can easily set the AK4645A's programmable filter.

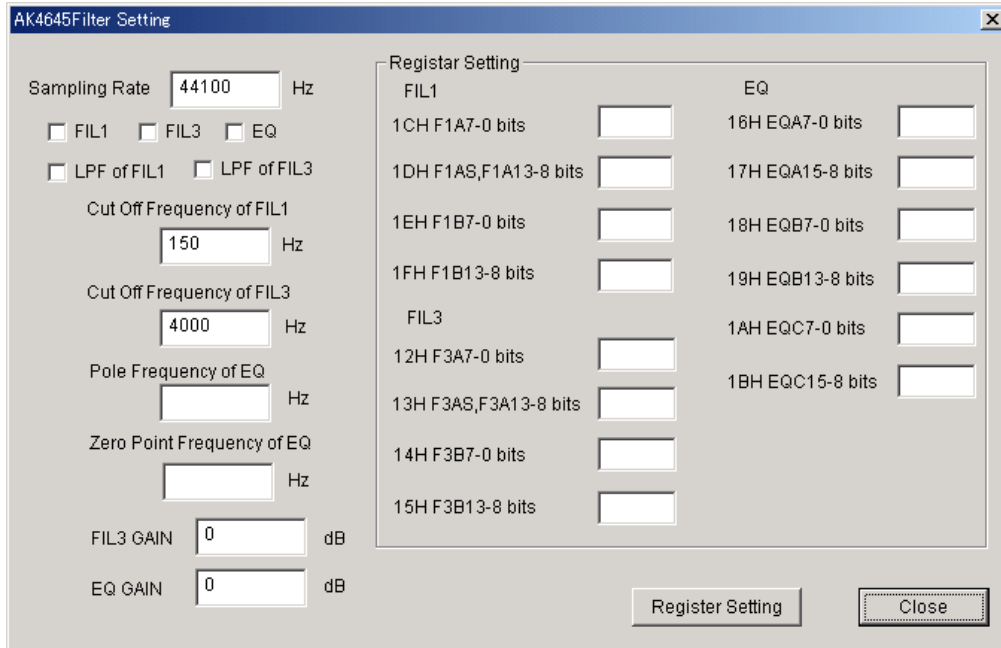

Figure 13 . [Filter] window

8-1. Value input columns on left side

- [Sampling Rate] → Input value of sampling frequency [unit : Hz] <default : 44100>
- [Cut Off Frequency of FIL1] → Input value of cut off frequency of FIL1 [unit : Hz] <default : 150>
- [Cut Off Frequency of FIL3] → Input value of cut off frequency of FIL3 [unit : Hz] <default : 4000>
- [Pole Frequency of EQ] → Input value of pole frequency of EQ [unit : Hz]
- [Zero Frequency of EQ] → Input value of zero frequency of EQ [unit : Hz]
- [FIL3 GAIN] → Input value of gain of FIL3 (0~-10dB) [unit : dB]
- [EQ GAIN] → Input value of gain of EQ (+12~0dB) [unit : dB]

8-2. Check box on left side

Check Box	Check	Check off
FIL1	FIL1 bit =“1”	FIL1 bit =“0”
FIL3	FIL3 bit =“1”	FIL3 bit =“0”
EQ	EQ bit =“1”	EQ bit =“0”
LPF of FIL1	F1AS bit =“1”(LPF)	F1AS bit =“0”(HPF)
LPF of FIL3	F3AS bit =“1”(LPF)	F3AS bit =“0”(HPF)

8-2. [Register Setting] panel and [Register Setting] button on right side

Click [Register setting] button, then filter coefficient set by 8-1 and 8-2 is written on [Register setting] panel. (It is also written to the actual control register of the AK4645A.)

MEASUREMENT RESULTS

1. EXT mode (slave mode)**[Measurement condition]**

- Measurement unit: Audio Precision, System two Cascade
- EXT Slave Mode
- MCLK: 256fs
- BICK: 64fs
- Bit: 16bit
- Measurement Frequency: 20Hz ~ 20kHz
- Power Supply: AVDD=DVDD=HVDD=TVDD=3.3V
- Temperature: Room
- Input Frequency: 1kHz
- Sampling Frequency: 44.1kHz

[Measurement Results]

ADC (LIN2/RIN2) characteristics (IVOL=0dB, ALC1 = OFF, LIN2/RIN2 → ADC → IVOL)

		L[dB]		R[dB]	
MIC-Amp Gain		0dB	+20dB	0dB	+20dB
S/(N+D)	20kHzLPF (-1dB)	90.1	84.1	89.7	83.7
DR	20kHzLPF + A-weighted	95.6	87.4	95.7	87.4
S/N	20kHzLPF + A-weighted	95.9	87.4	95.9	87.4

DAC (LOUT/ROUT) characteristics ($R_L=20k\Omega$, DAC → LOUT/ROUT)

		L[dB]	R[dB]
S/(N+D)	20kHzLPF (-3dB)	88.7	88.9
S/N	20kHzLPF + A-weighted	94.3	94.1

DAC (HPL/ HPR) characteristics ($R_L=22.8\Omega$, DAC → HPL/ HPR)

		L[dB]	R[dB]
S/(N+D)	20kHzLPF (-3dB)	66.8	67.3
S/N	20kHzLPF + A-weighted	91.3	91.4

2. PLOT DATA

2-1 ADC (LIN2/RIN2 → ADC) (0dB)

AK4645A LIN2->ADC FFT
fs=44.1kHz,fin=1kHz,-1dB input

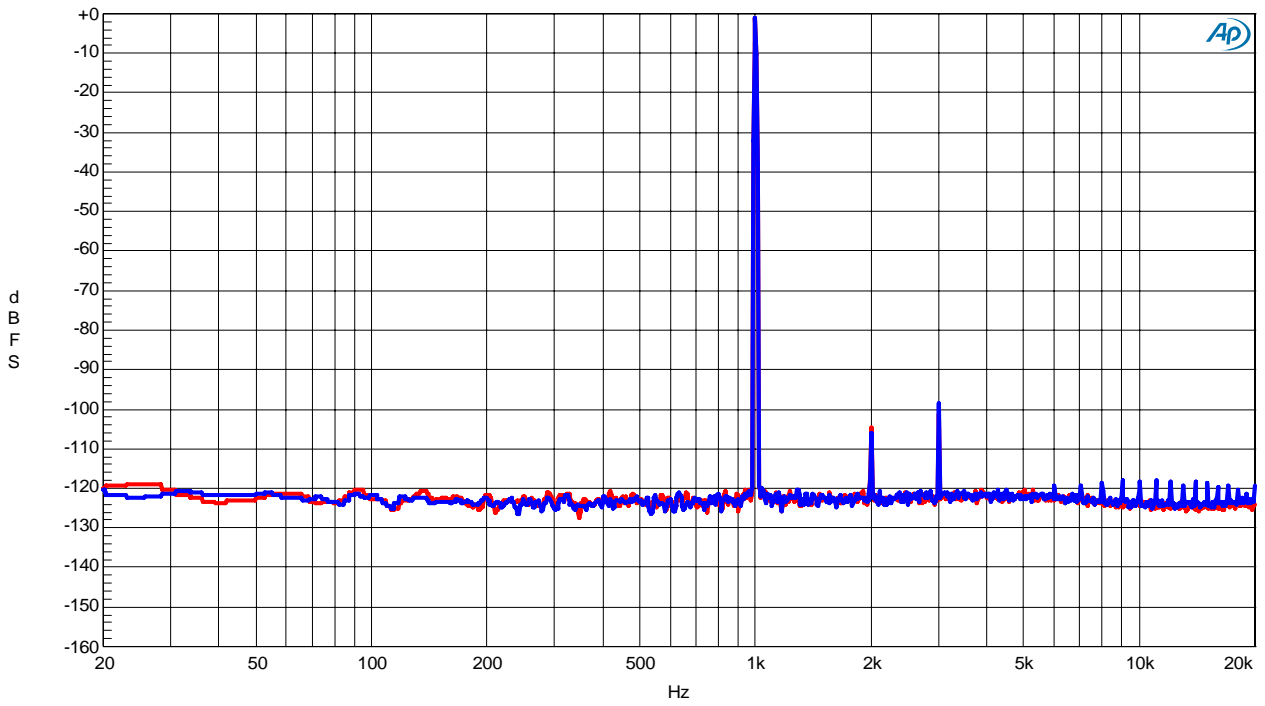

Figure 14. FFT Plot (Input level= 0dBFS)

AK4645A LIN2->ADC FFT
fs=44.1kHz,fin=1kHz,-60dB input

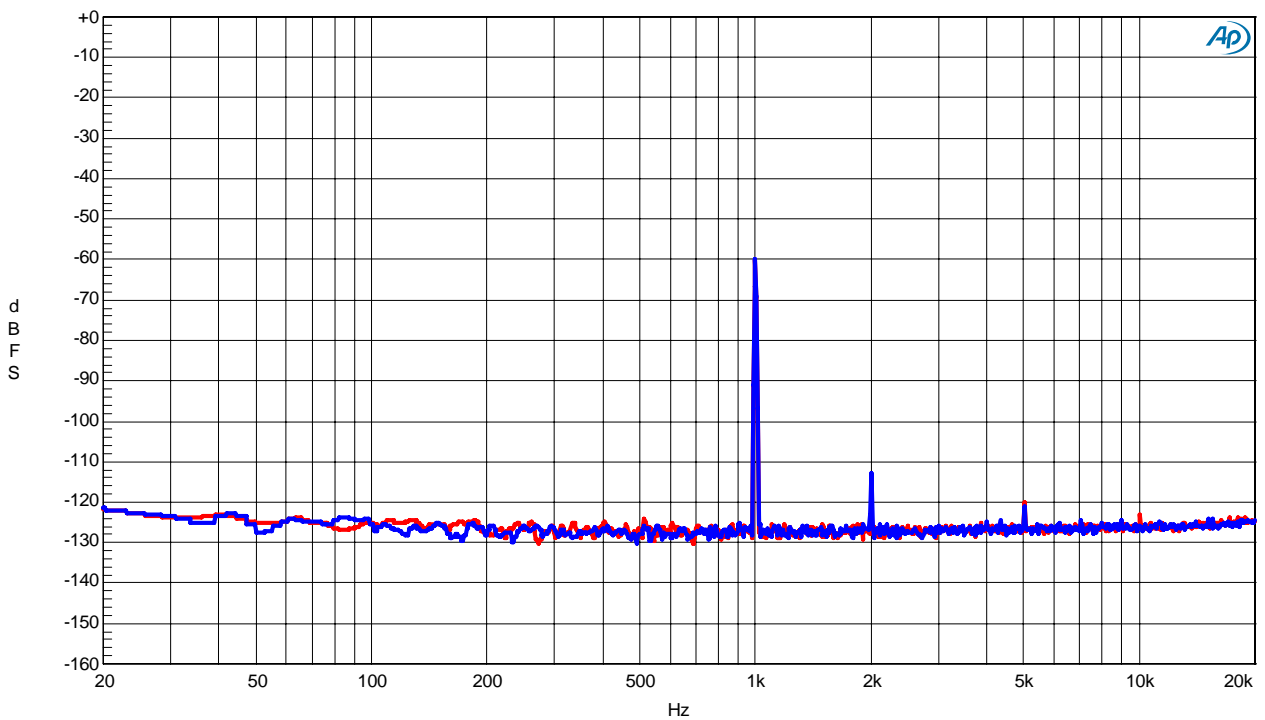

Figure 15. FFT Plot (Input level= -60dBFS)

AK4645A LIN2->ADC FFT
fs=44.1kHz,fin=1kHz,No Signal

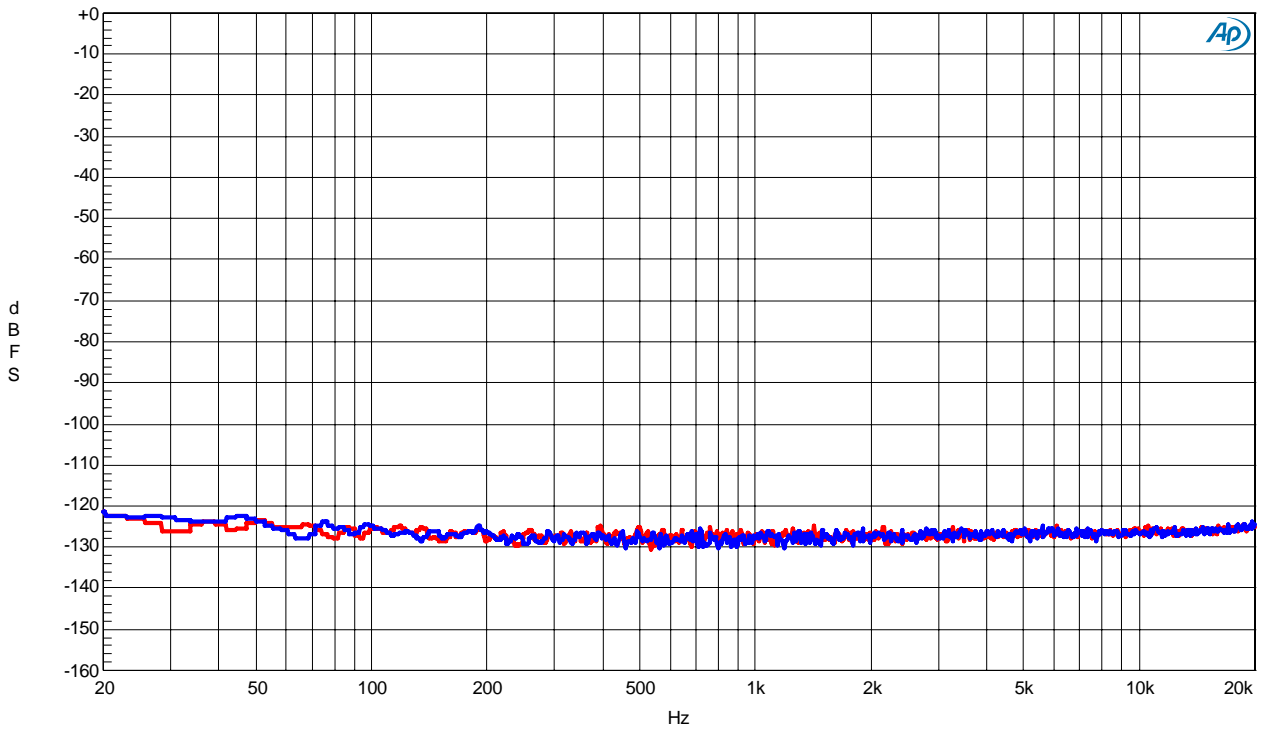

Figure 16. FFT Plot (No signal)

AK4645A LIN2->ADC THD+N vs. Input Level
fs=44.1kHz,fin=1kHz

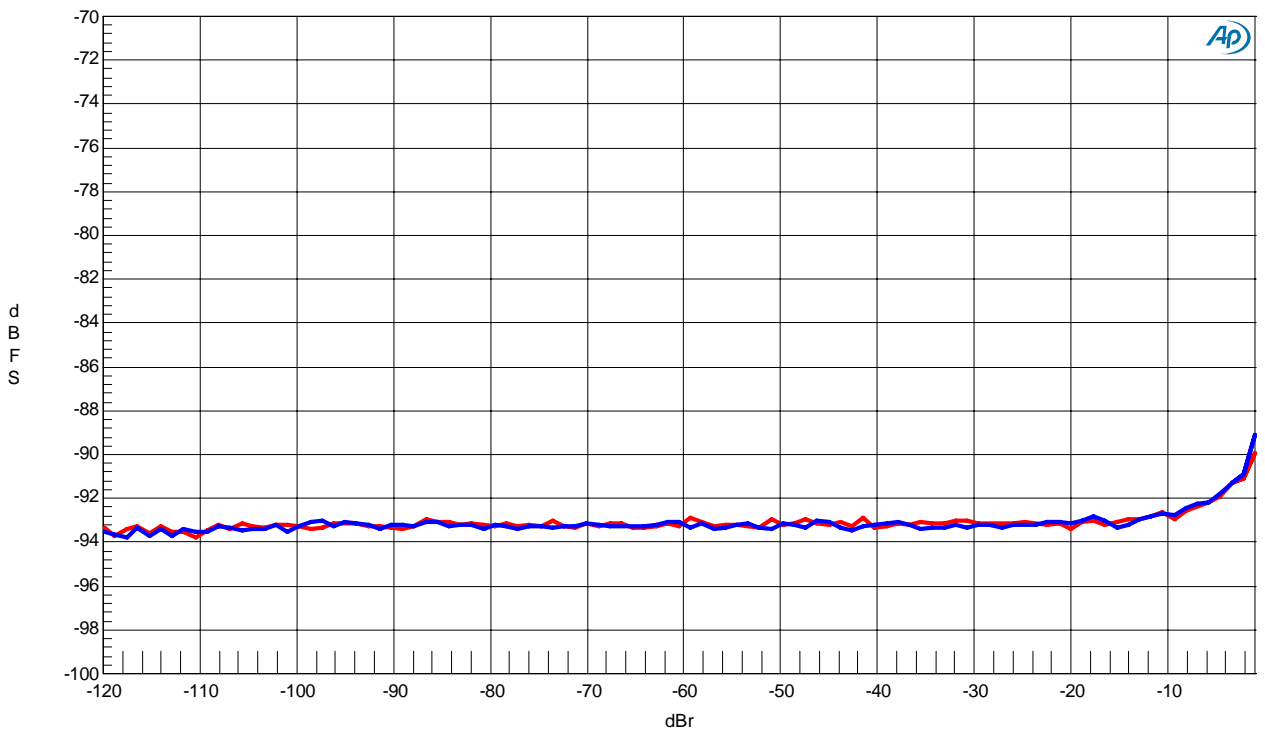

Figure 17. THD+N vs. Input Level

AK4645A LIN2->ADC THD+N vs. Input Frequency
fs=44.1kHz

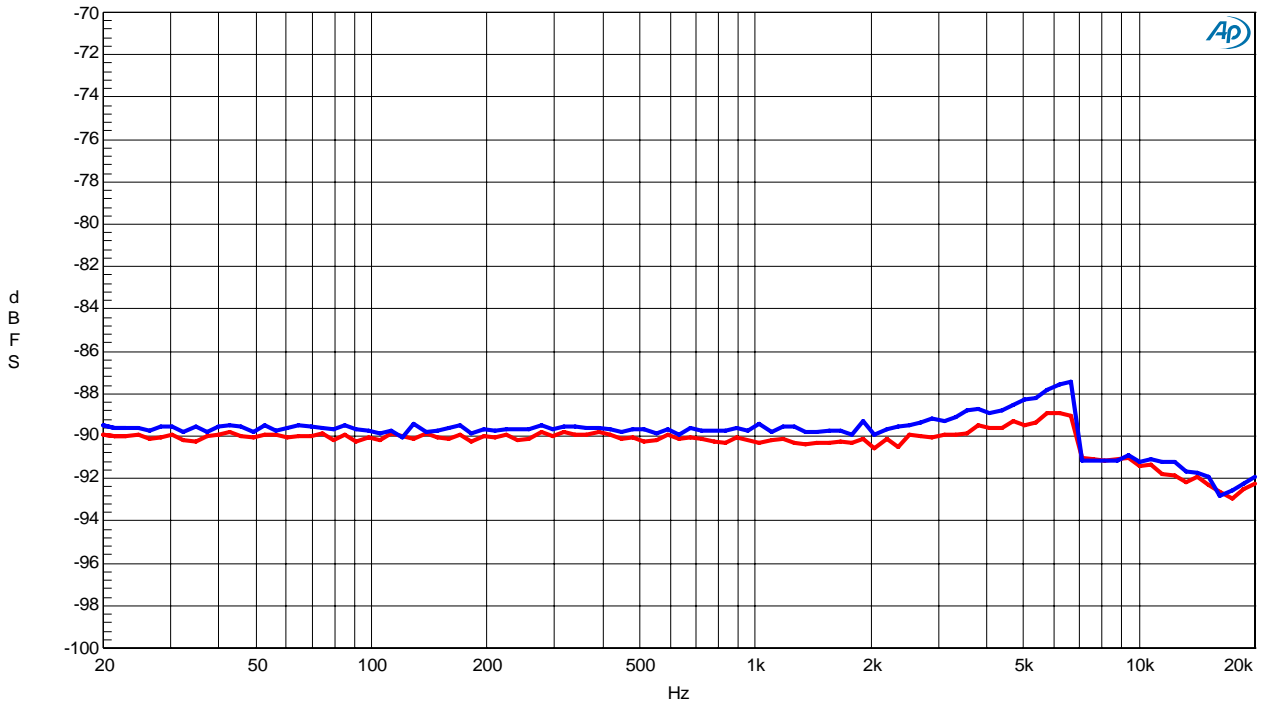

Figure 18. THD+N vs. Input Frequency

AK4645A LIN2->ADC Linearity
fs=44.1kHz,fin=1kHz

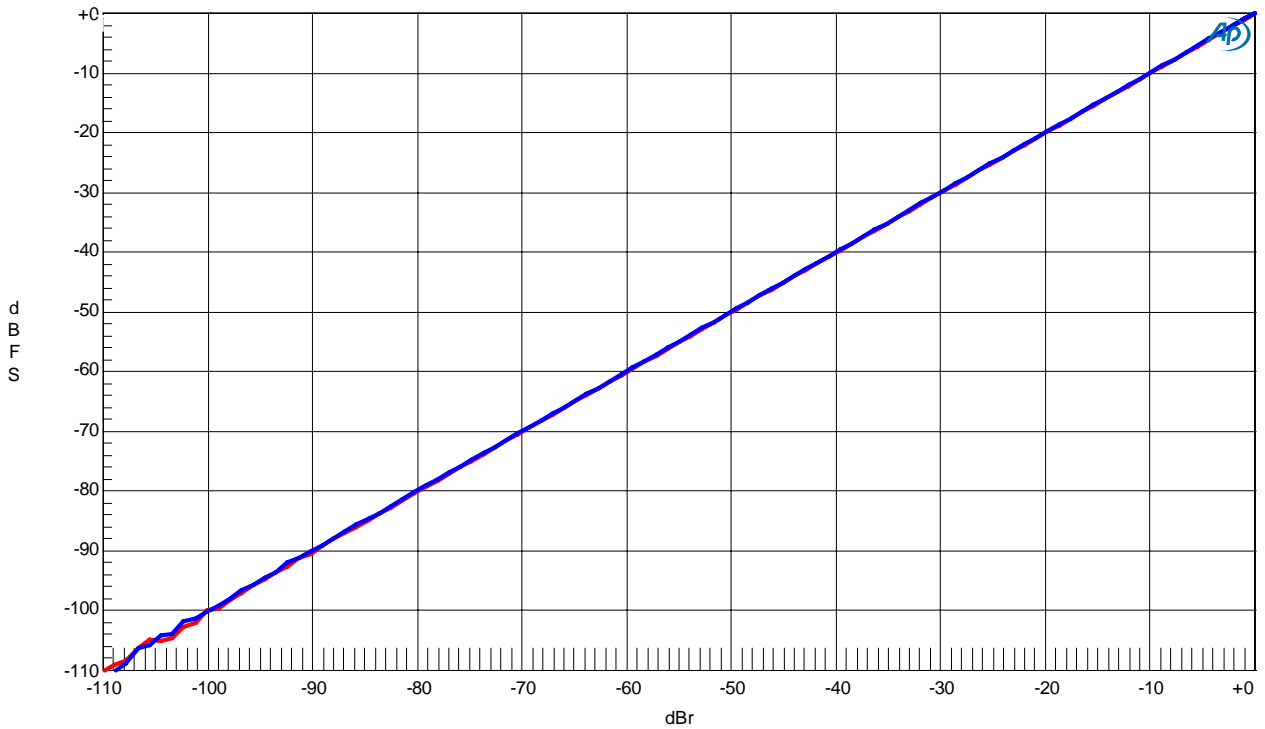

Figure 19. Linearity

AK4645A LIN2->ADC Frequency Response
fs=44.1kHz,-1dB Input

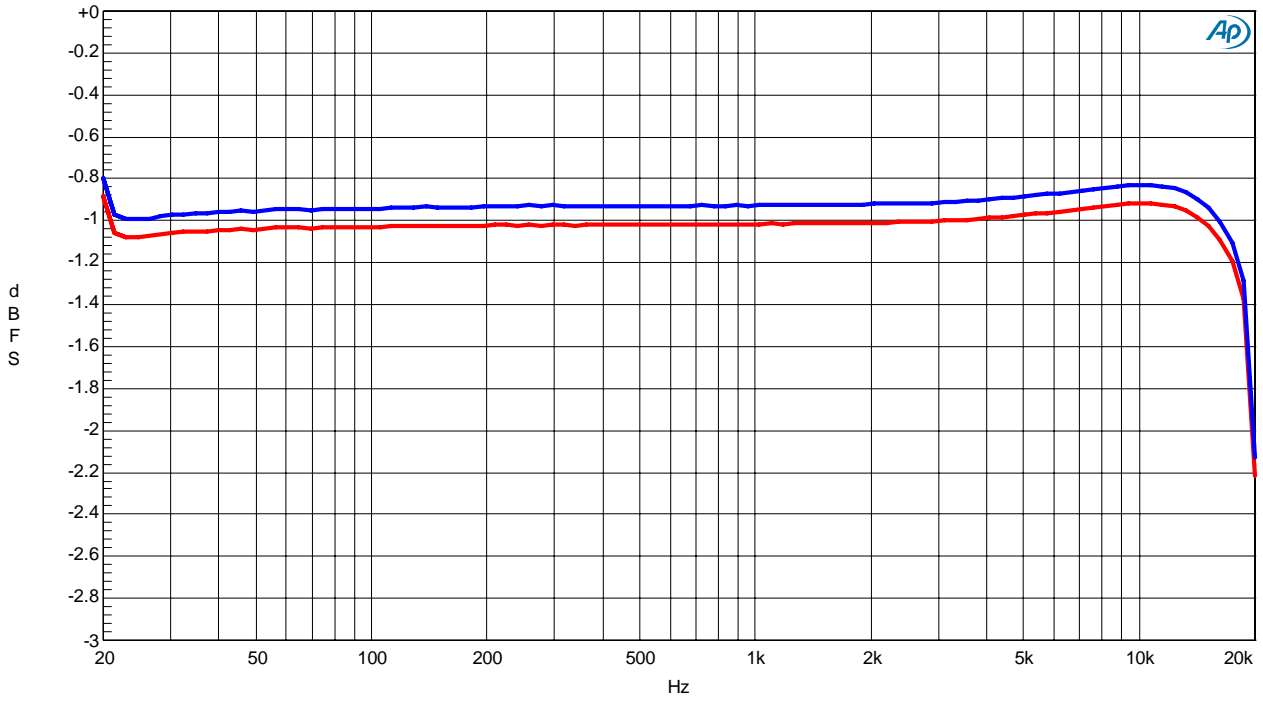

Figure 20. Frequency Response

AK4645A LIN2->ADC Crosstalk
fs=44.1kHz,-1dB Input

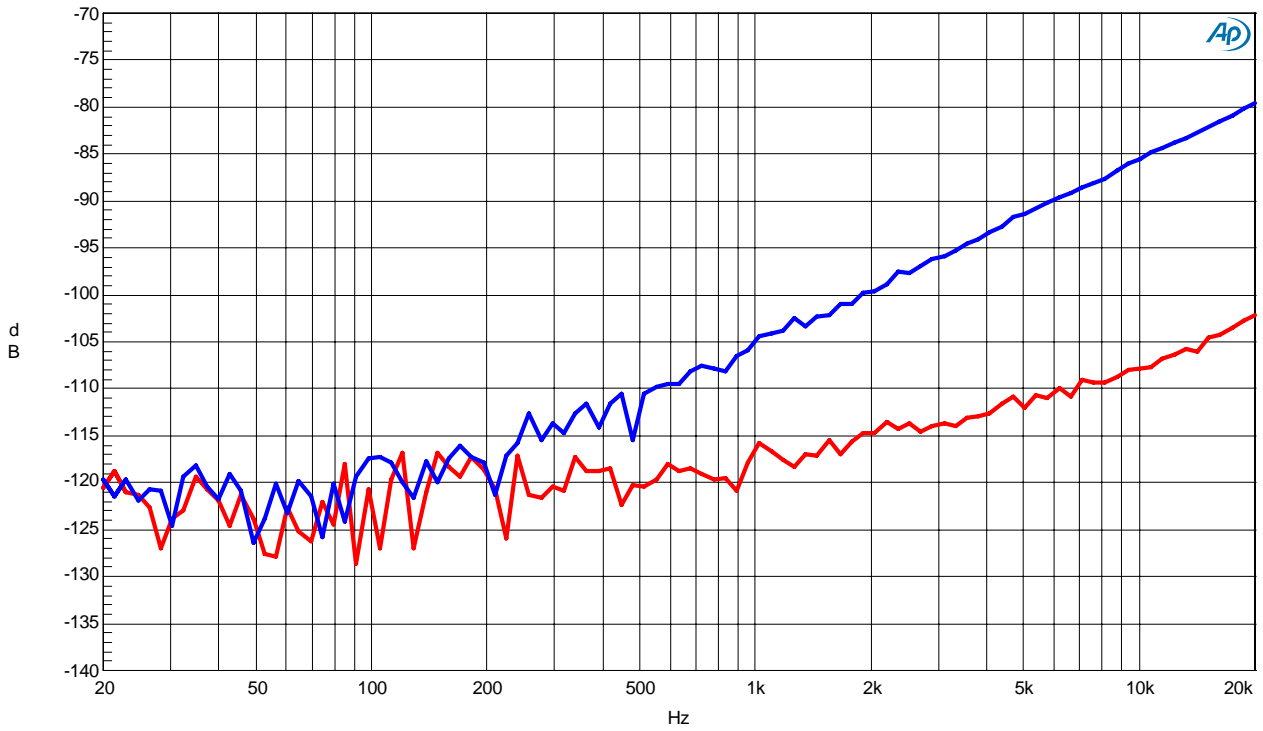

Figure 21. Crosstalk Plot

2-2 ADC (LIN2/RIN2 → ADC) (+20dB)

AK4645A LIN2->ADC(MIC=+20dB) FFT
fs=44.1kHz,fin=1kHz,-1dB Input

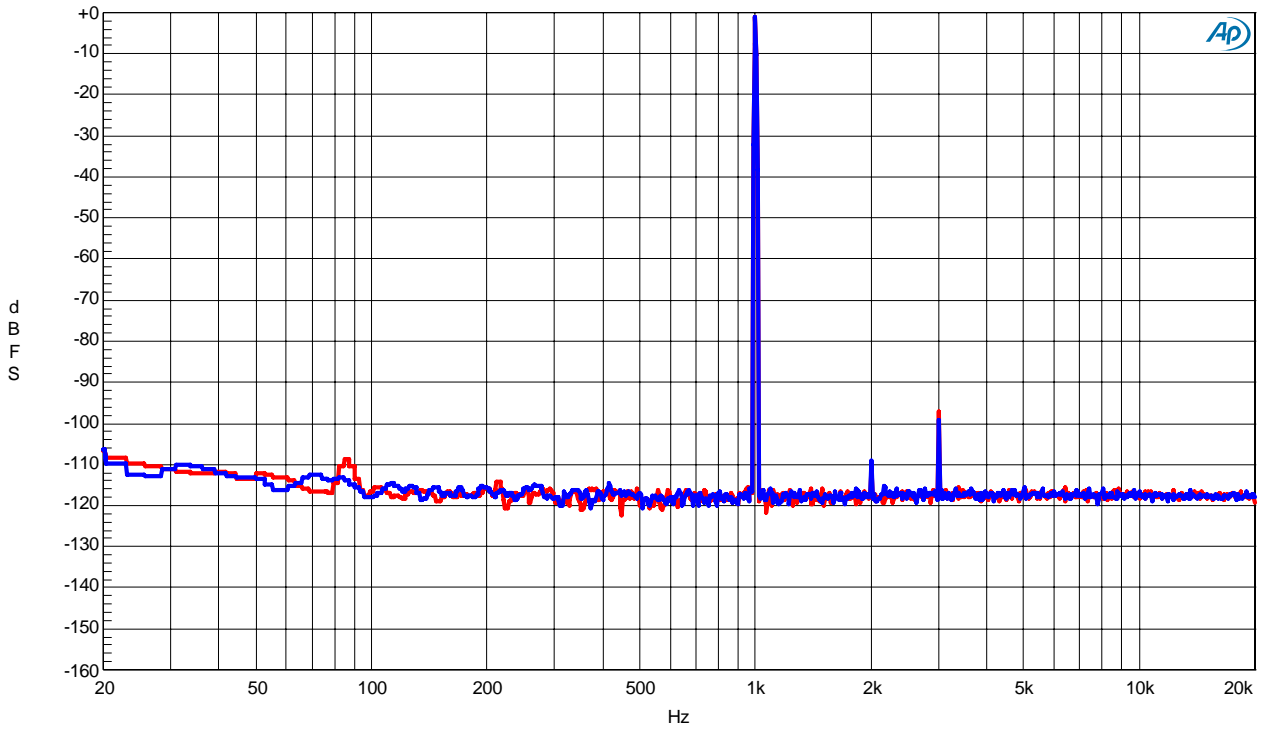

Figure 22. FFT Plot (Input level= 0dBFS)

AK4645A LIN2->ADC(MIC=+20dB) FFT
fs=44.1kHz,fin=1kHz,-60dB Input

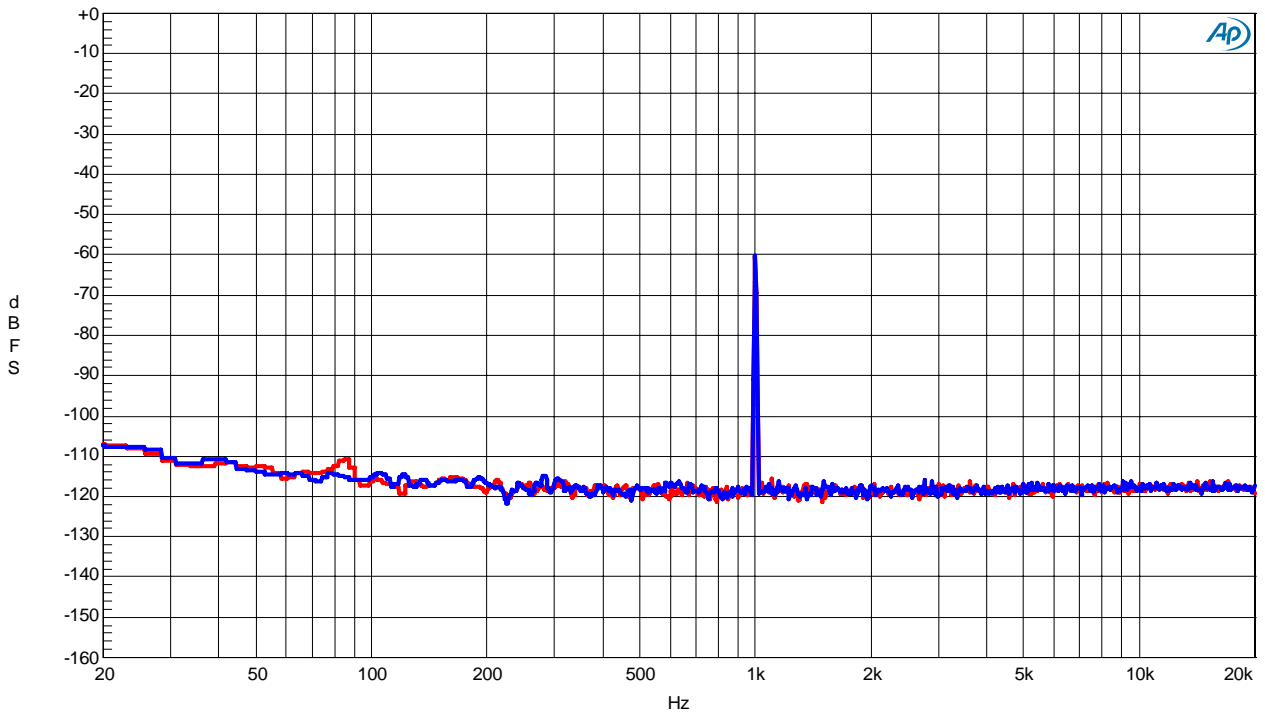

Figure 23. FFT Plot (Input level= -60dBFS)

AK4645A LIN2->ADC(MIC=+20dB) FFT
fs=44.1kHz,fin=1kHz,No Signal

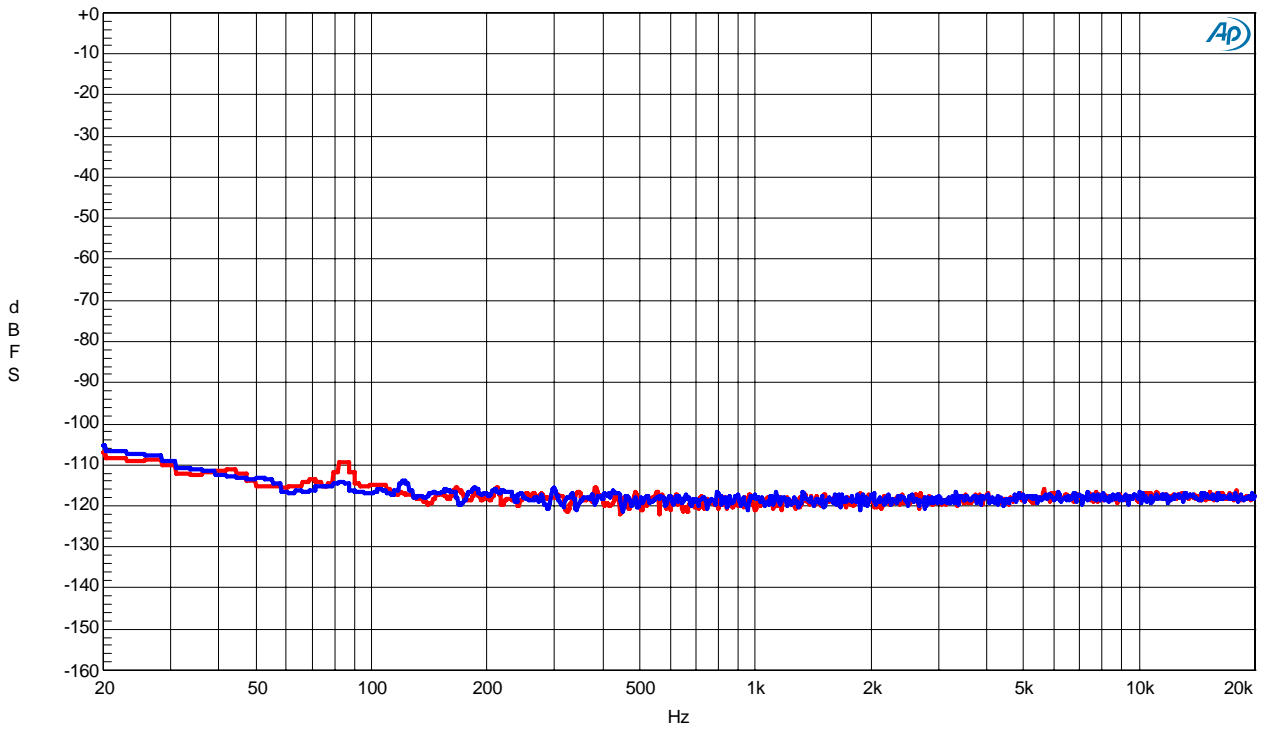

Figure 24. FFT Plot (No signal)

AK4645A LIN2->ADC(MIC=+20dB) THD+N vs. Input Level
fs=44.1kHz,fin=1kHz

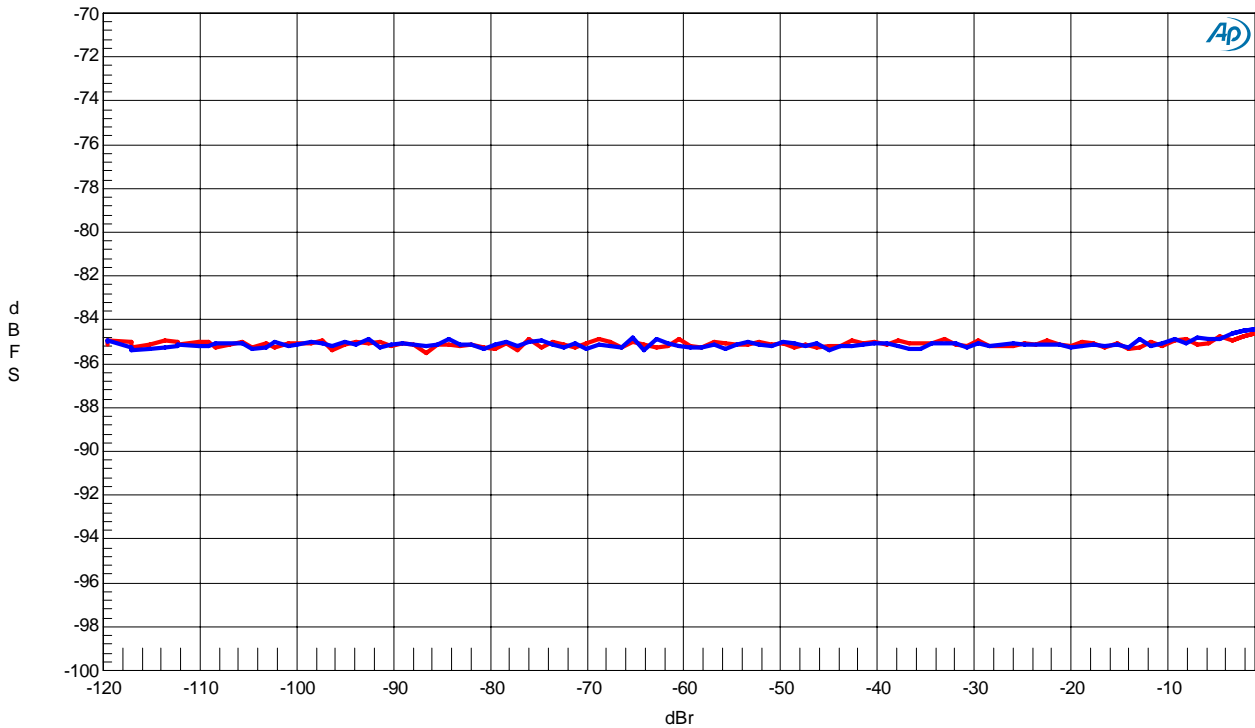

Figure 25. THD+N vs. Input Level

AK4645A LIN2->ADC(MIC=+20dB) THD+N vs. Input Frequency
fs=44.1kHz,-1dB Input

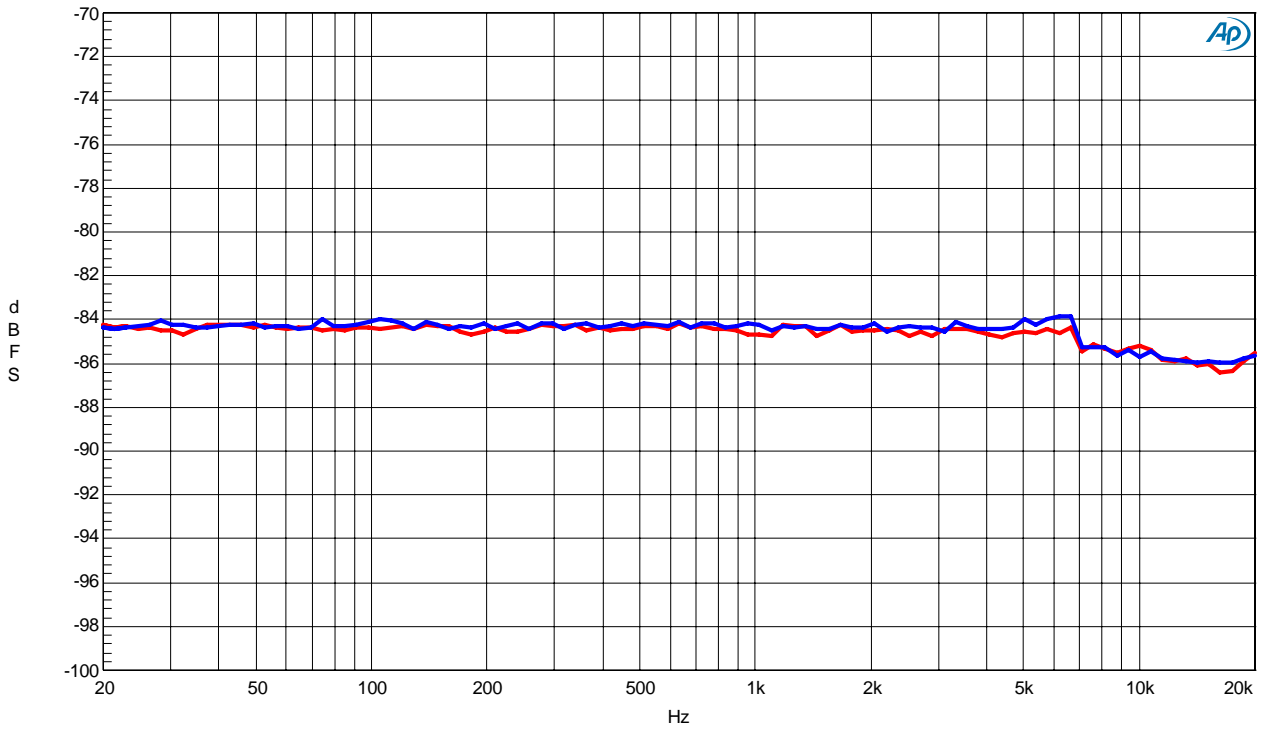

Figure 26. THD+N vs. Input Frequency

AK4645A LIN2->ADC(MIC=+20dB) Linearity
fs=44.1kHz,fin=1kHz

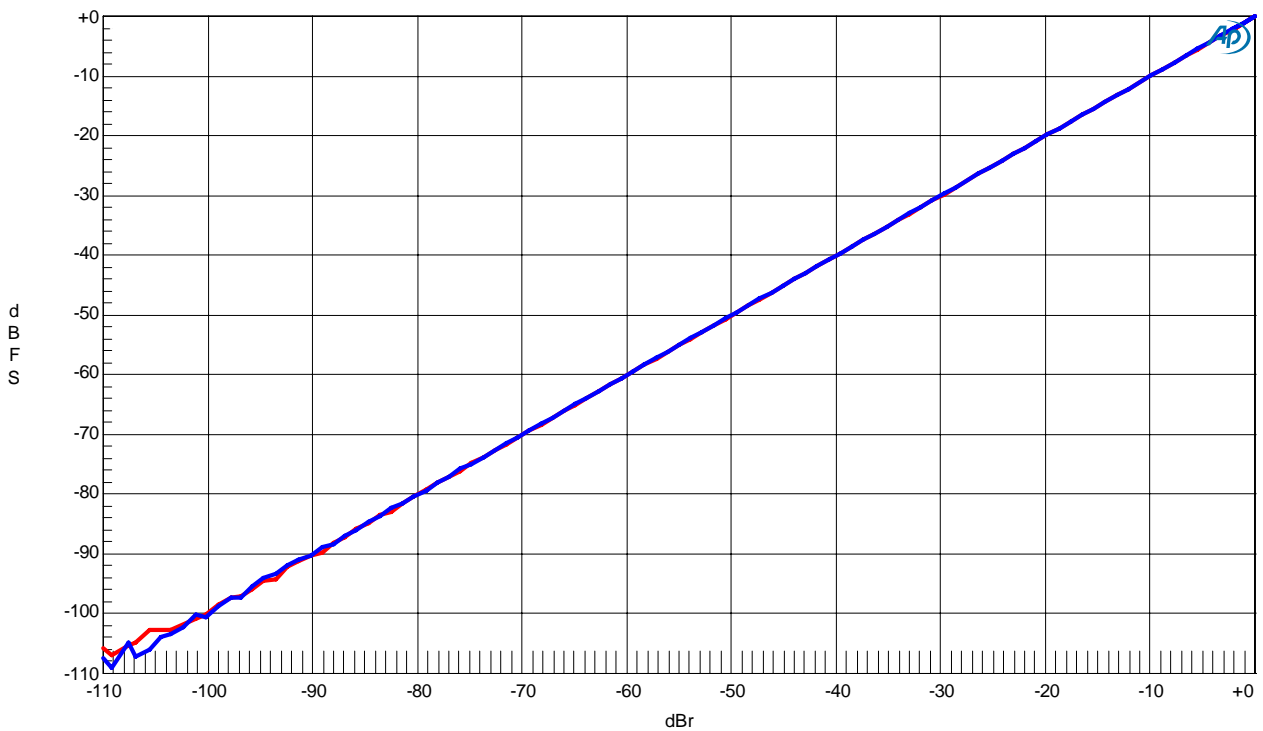

Figure 27. Linearity

AK4645A LIN2->ADC(MIC=+20dB) Frequency Response
fs=44.1kHz,-1dB Input

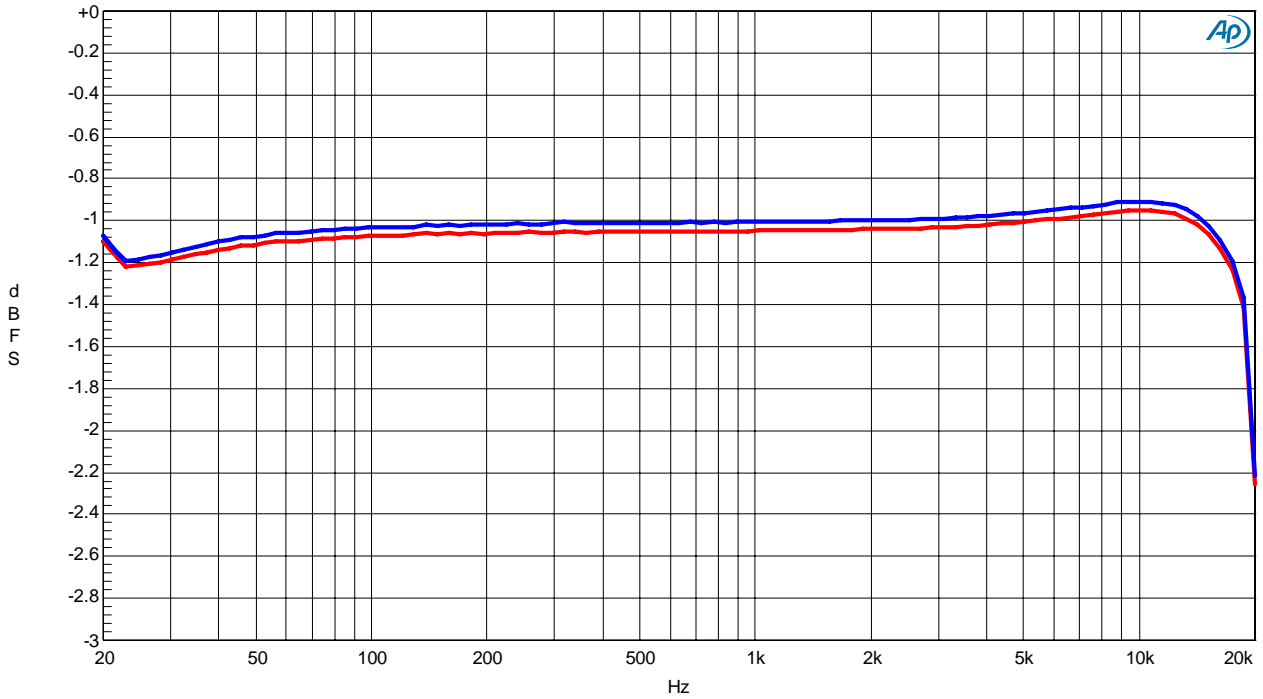

Figure 28. Frequency Response

AK4645A LIN2->ADC(MIC=+20dB) Crosstalk
fs=44.1kHz,-1dB Input

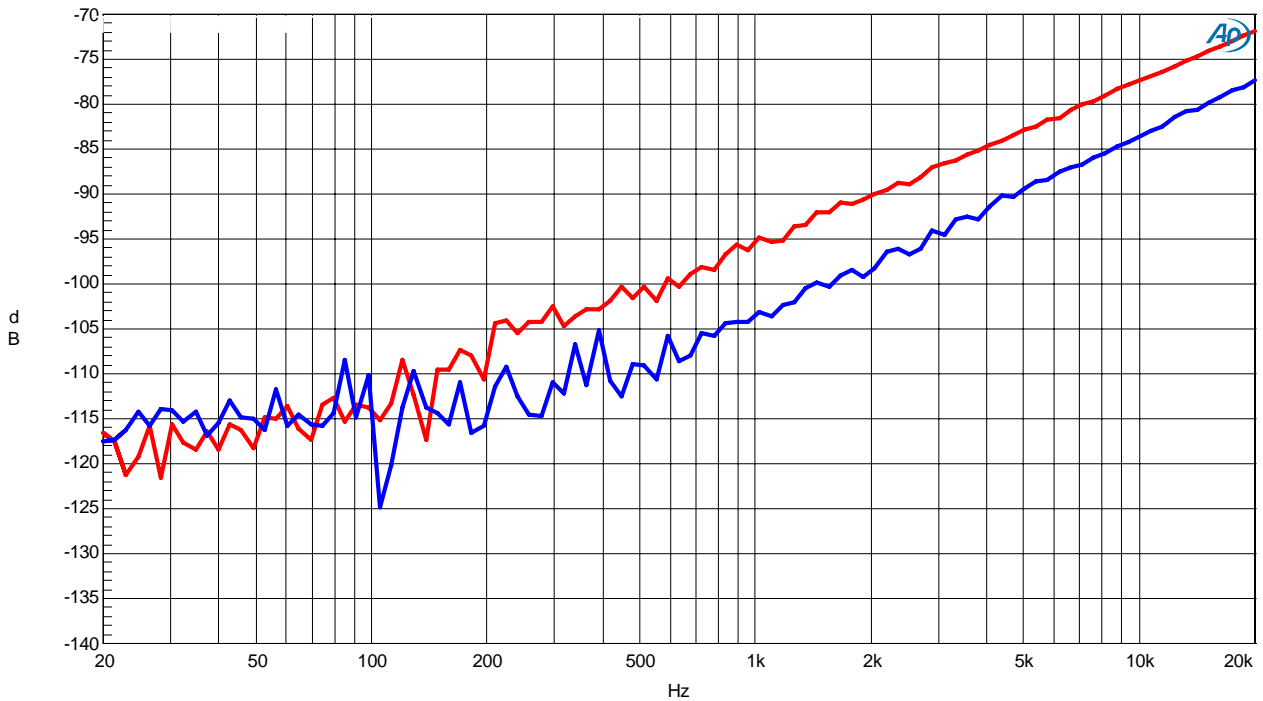

Figure 29. Crosstalk Plot

2-3 DAC (DAC → LOUT/ROUT)

AK4645A DAC LOUT/ROUT FFT
fs=44.1kHz, fin=1kHz, 0dB Input

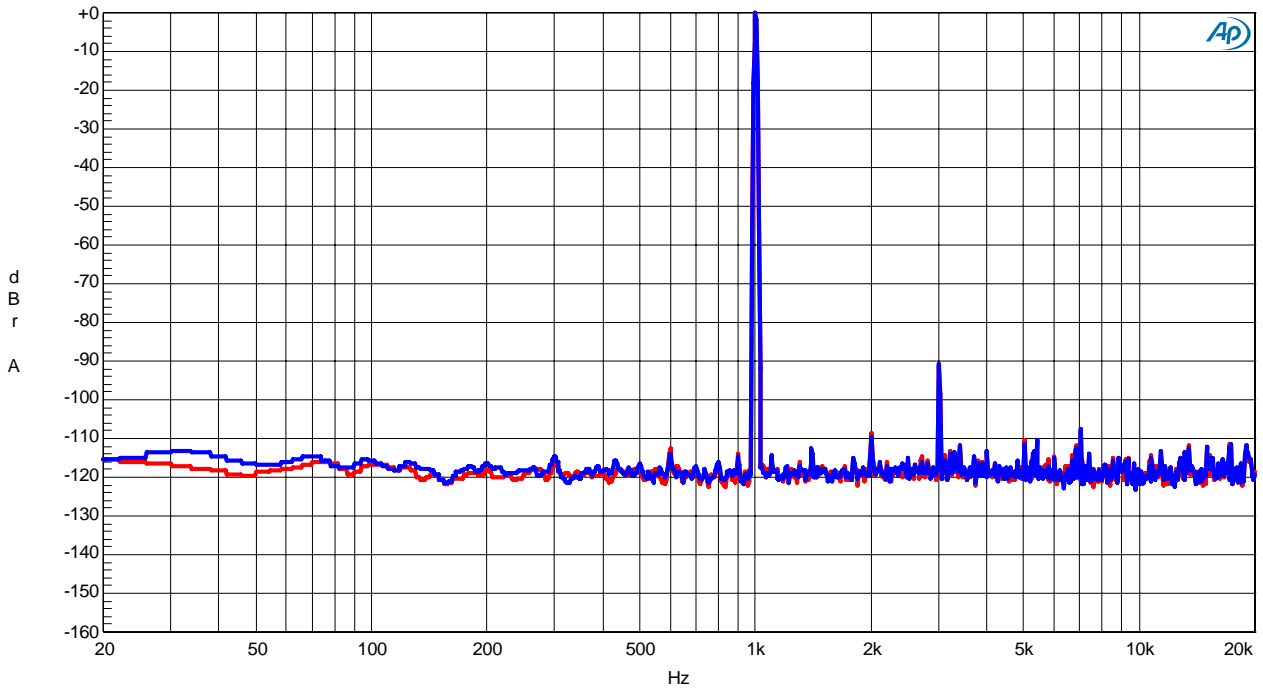

Figure 30. FFT Plot (Input level= 0dBFs)

AK4645A DAC LOUT/ROUT FFT
fs=44.1kHz, fin=1kHz, -60dB Input

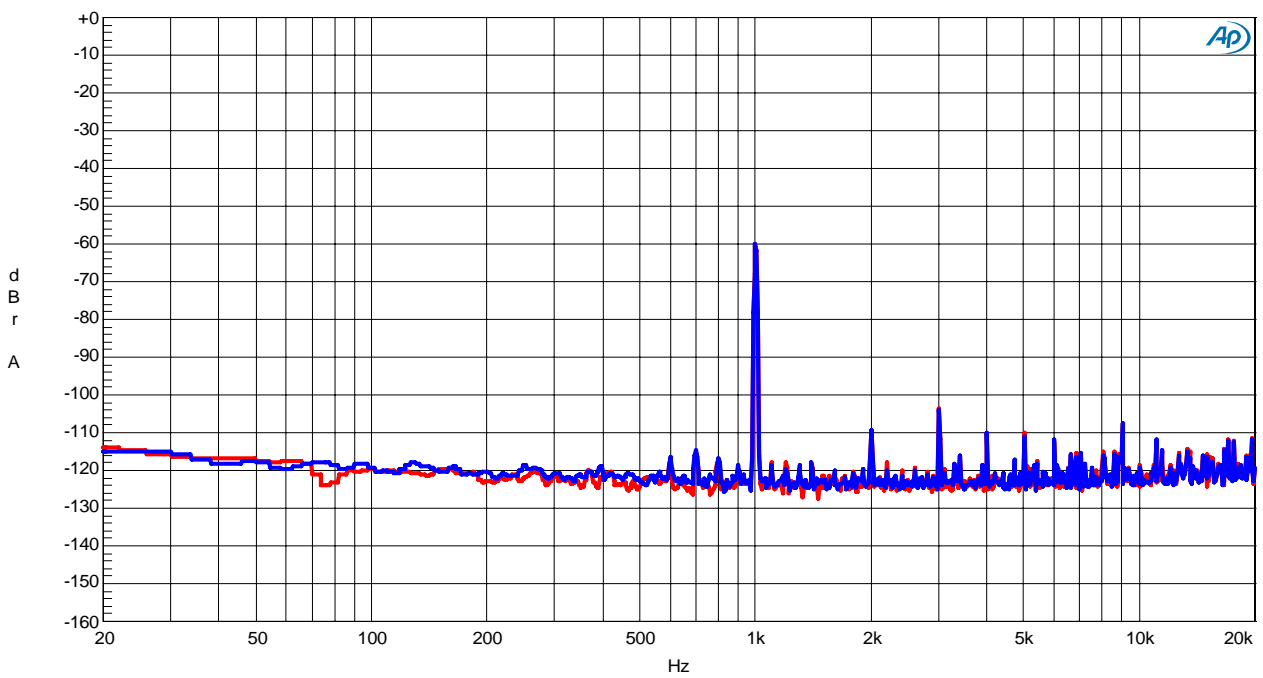

Figure 31. FFT Plot (Input level= -60dBFs)

AK4645A DAC LOU/ROUT FFT
fs=44.1kHz,fin=1kHz,No Signal

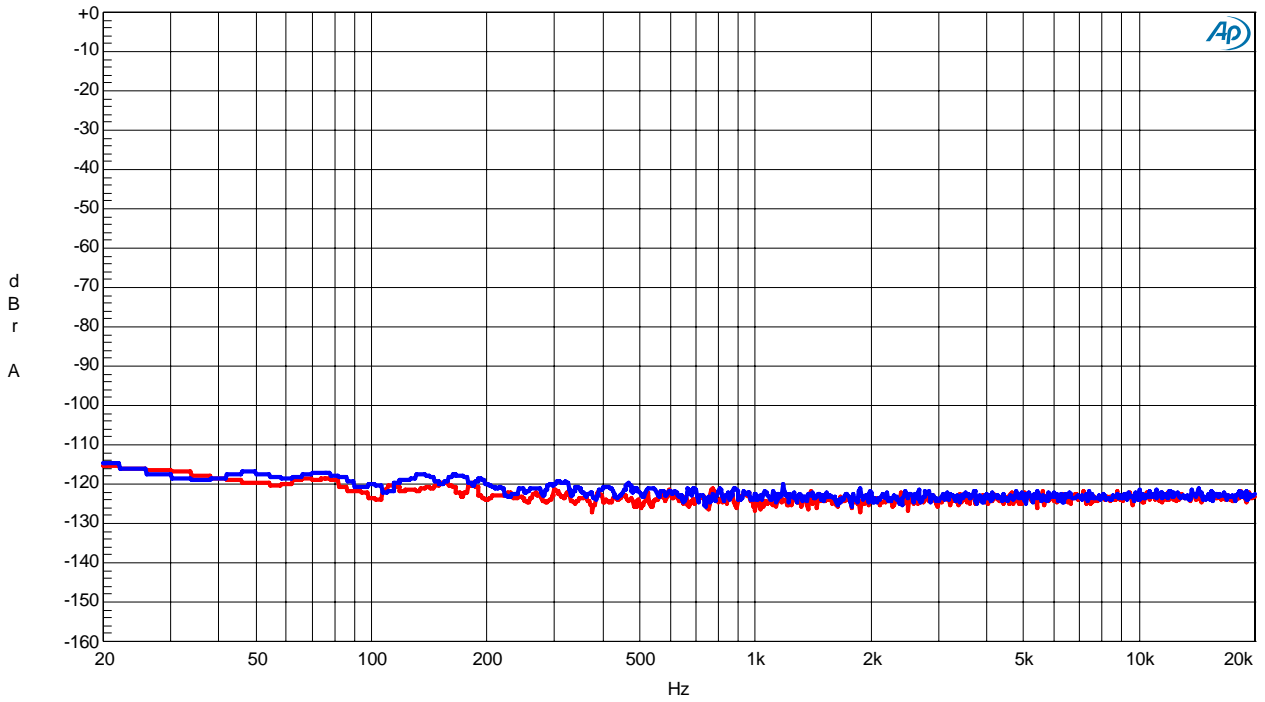

Figure 32. FFT Plot (No signal)

AK4645A DAC LOU/ROUT THD+N vs. Input Level
fs=44.1kHz,fin=1kHz

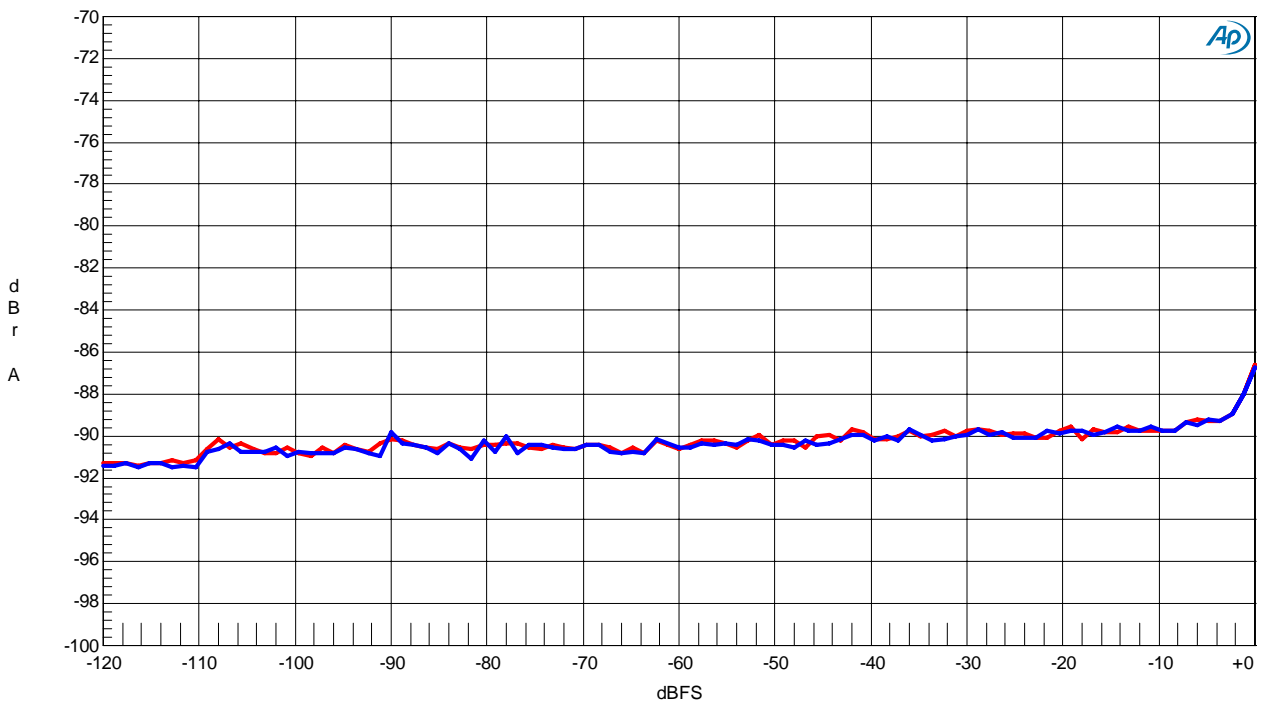

Figure 33. THD+N vs. Input Level

AK4645A DAC LOU/ROUT THD+N vs. Input Frequency
fs=44.1kHz,0dB Input

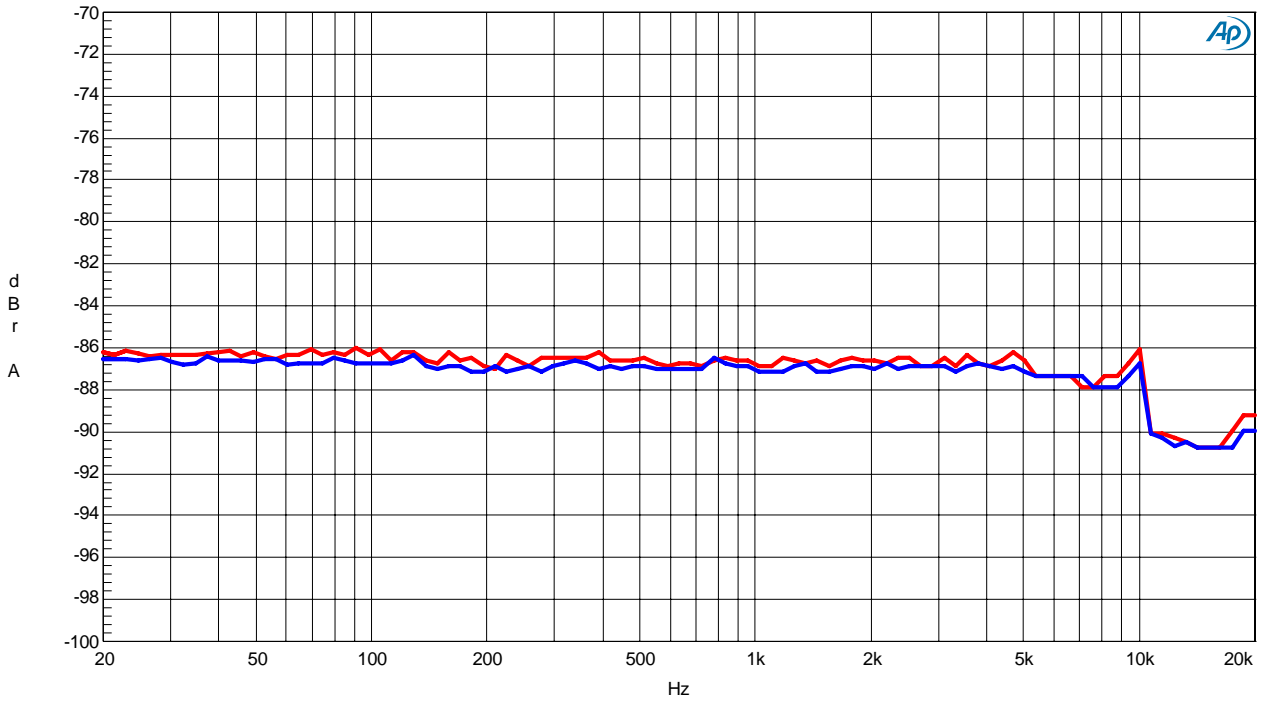

Figure 34. THD+N vs. Input Frequency

AK4645A DAC LOU/ROUT Linearity
fs=44.1kHz,fin=1kHz

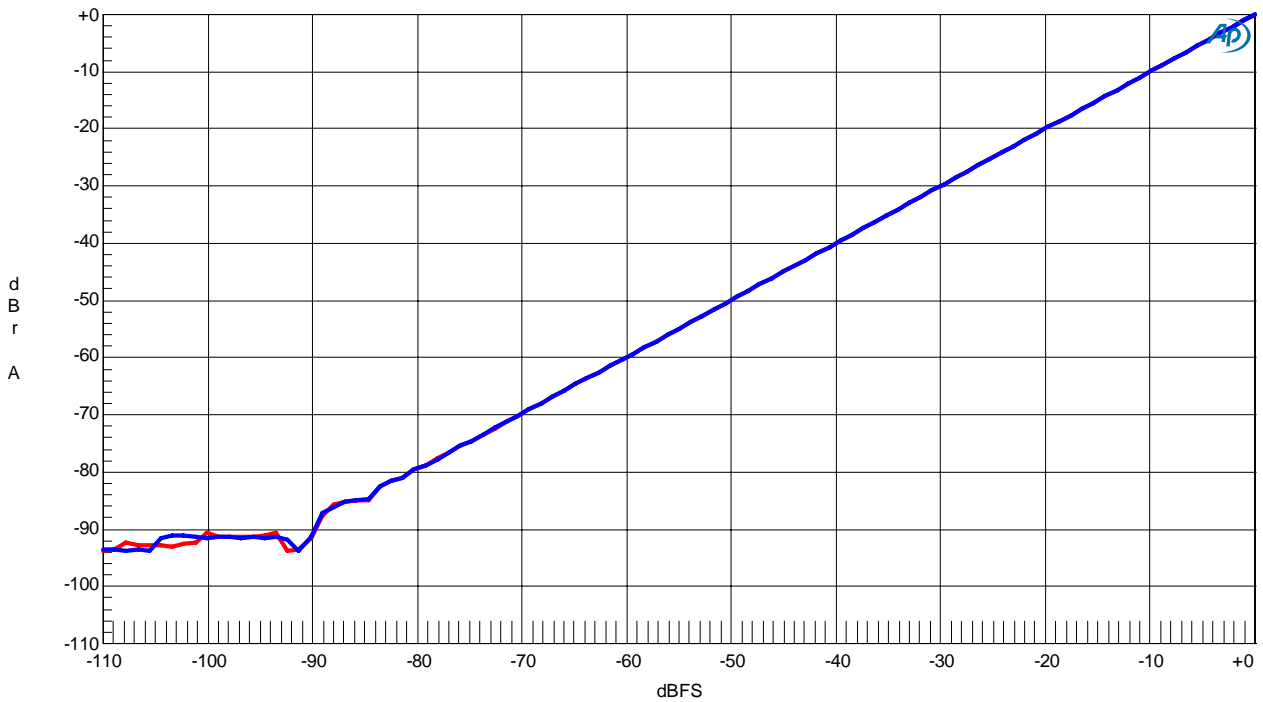

Figure 35. Linearity

AK4645A DAC LOU/ROUT Frequency Response
fs=44.1kHz,0dB Input

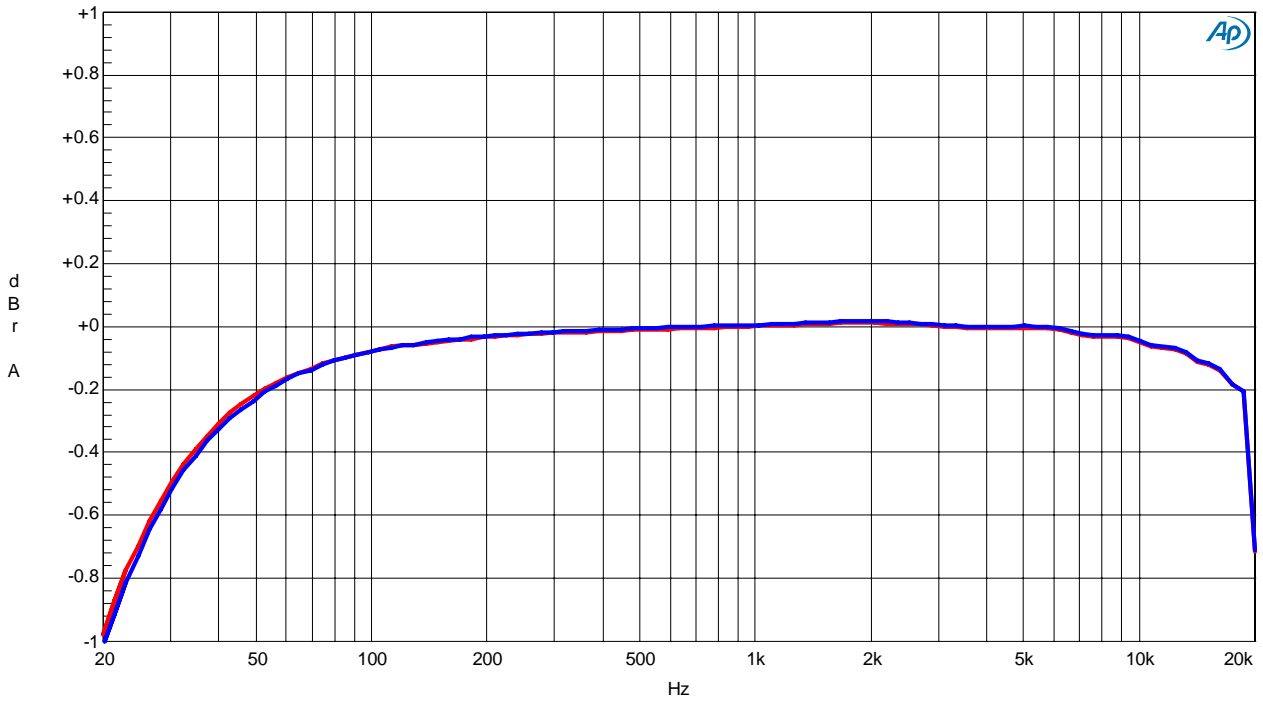

Figure 36. Frequency Response

AK4645A DAC LOU/ROUT Crosstalk
fs=44.1kHz,0dB Input

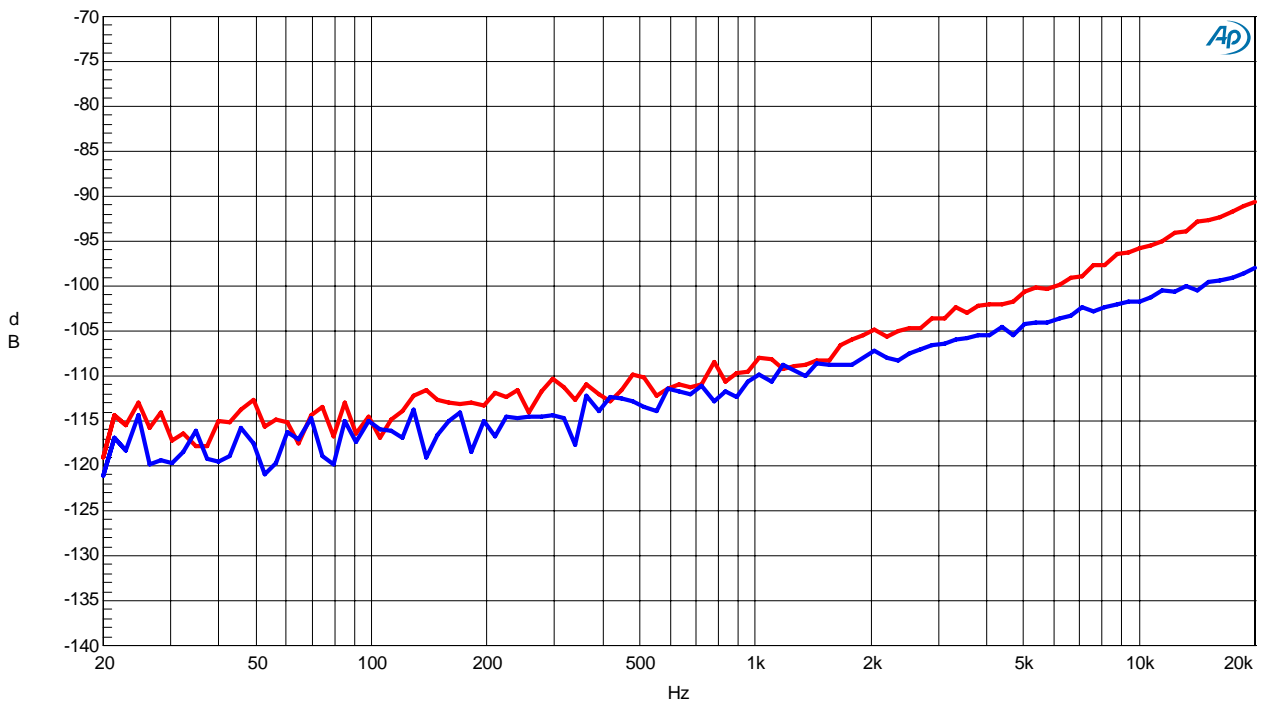

Figure 37. Crosstalk Plot

2-4 DAC (DAC→ HPL/HPR)

AK4645A DAC HPL/HPR FFT
fs=44.1kHz,fin=1kHz,0dB Input

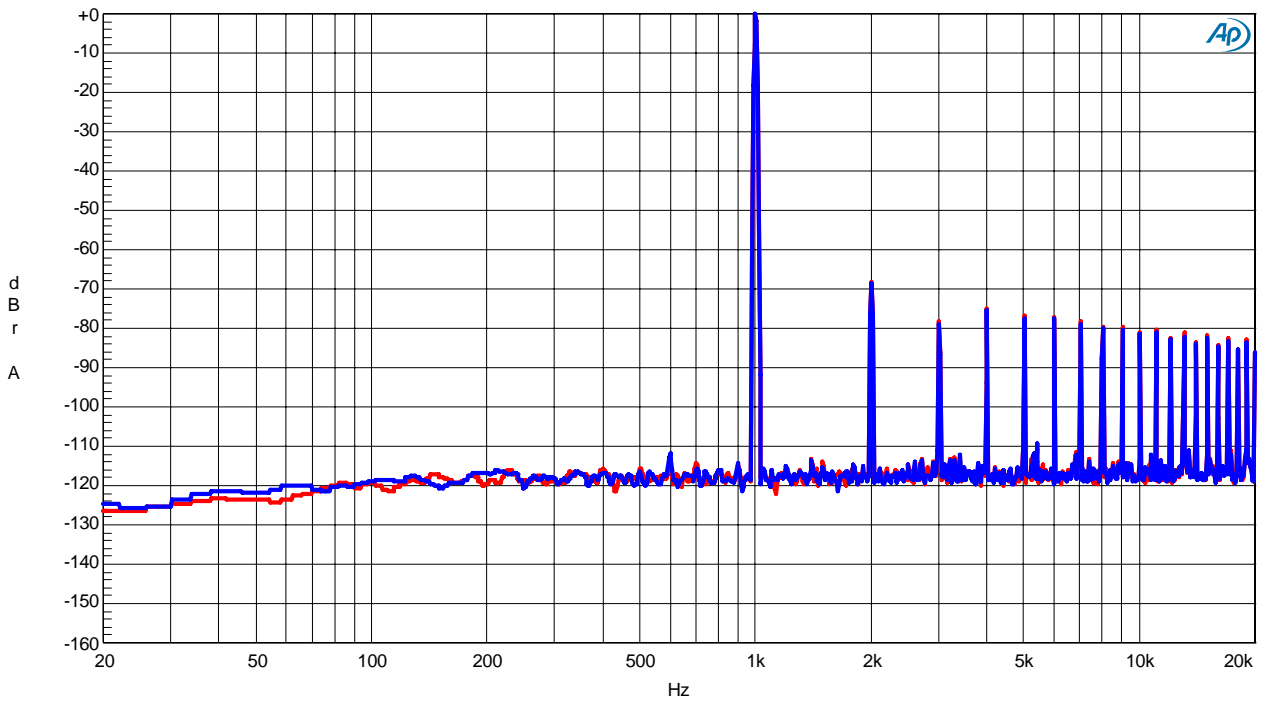

Figure 38. FFT Plot (Input level= 0dBFs)

AK4645A DAC HPL/HPR FFT
fs=44.1kHz,fin=1kHz,-60dB Input

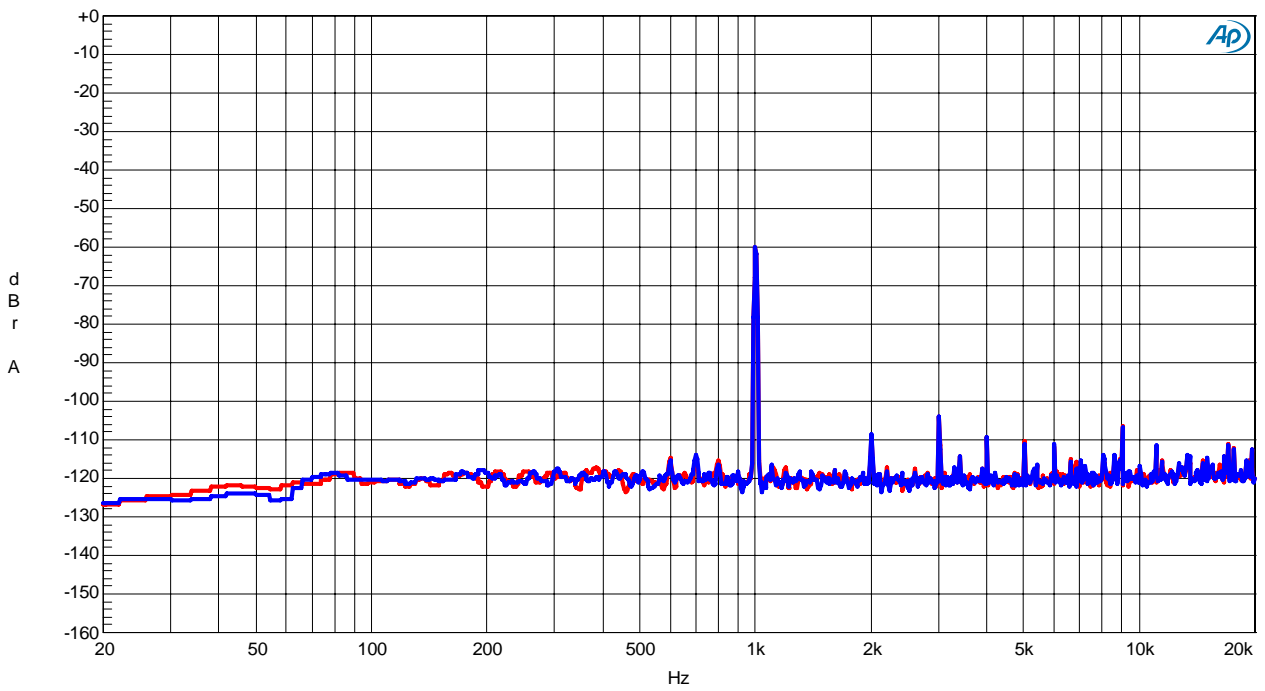

Figure 39. FFT Plot (Input level= -60dBFs)

AK4645A DAC HPL/HPR FFT
fs=44.1kHz,fin=1kHz,No Signal

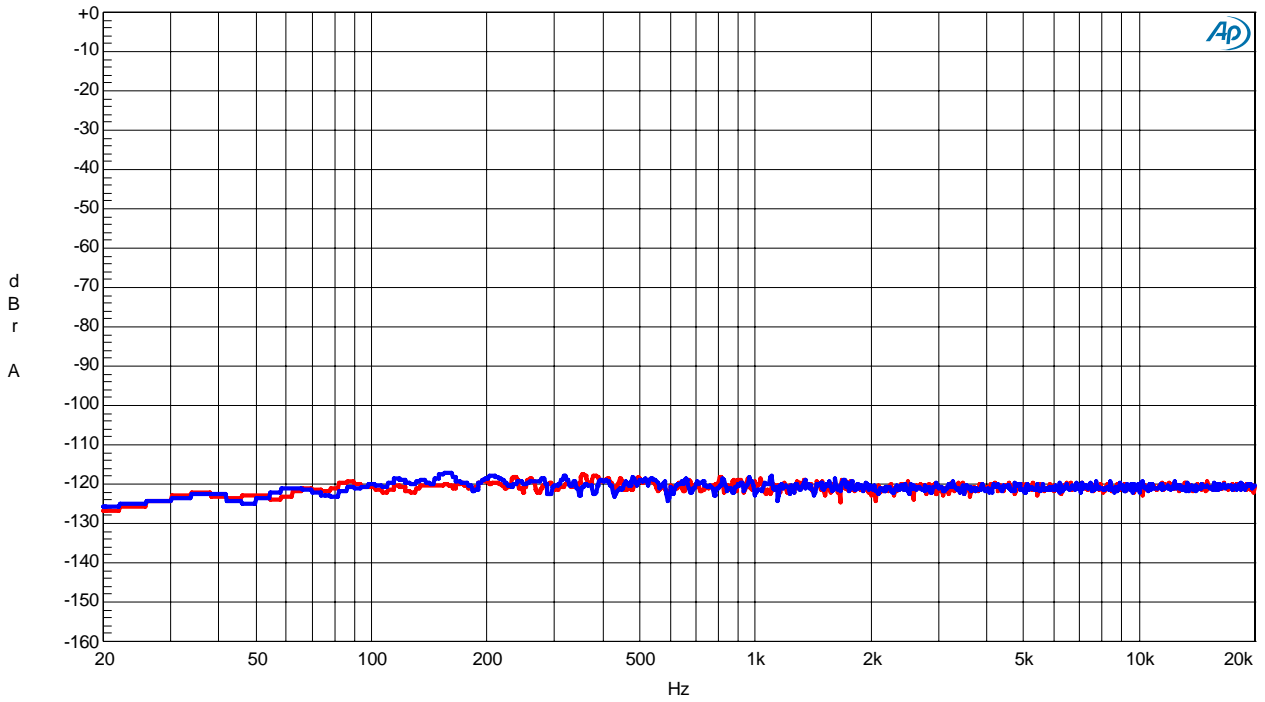

Figure 40. FFT Plot (No signal)

AK4645A DAC HPL/HPR THD+N vs. Input Level
fs=44.1kHz,fin=1kHz

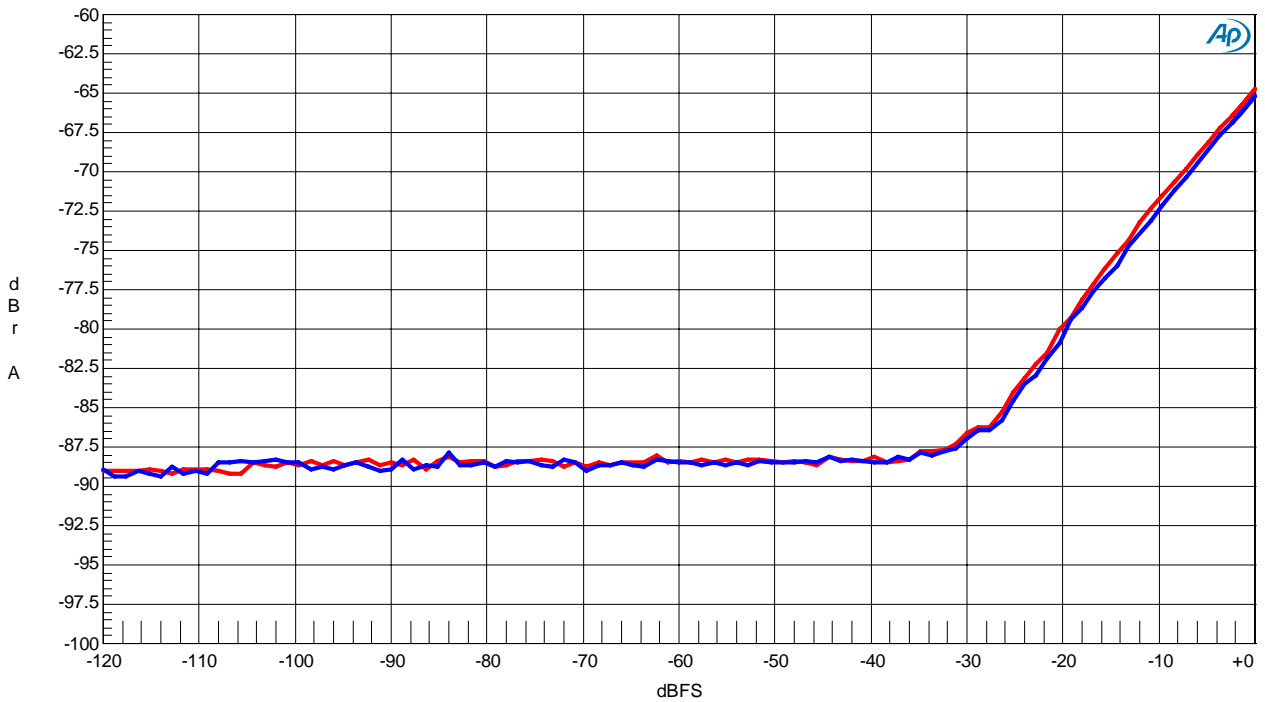

Figure 41. THD+N vs. Input Level

AK4645A DAC HPL/HPR THD+N vs. Input Frequency
fs=44.1kHz,0dB Input

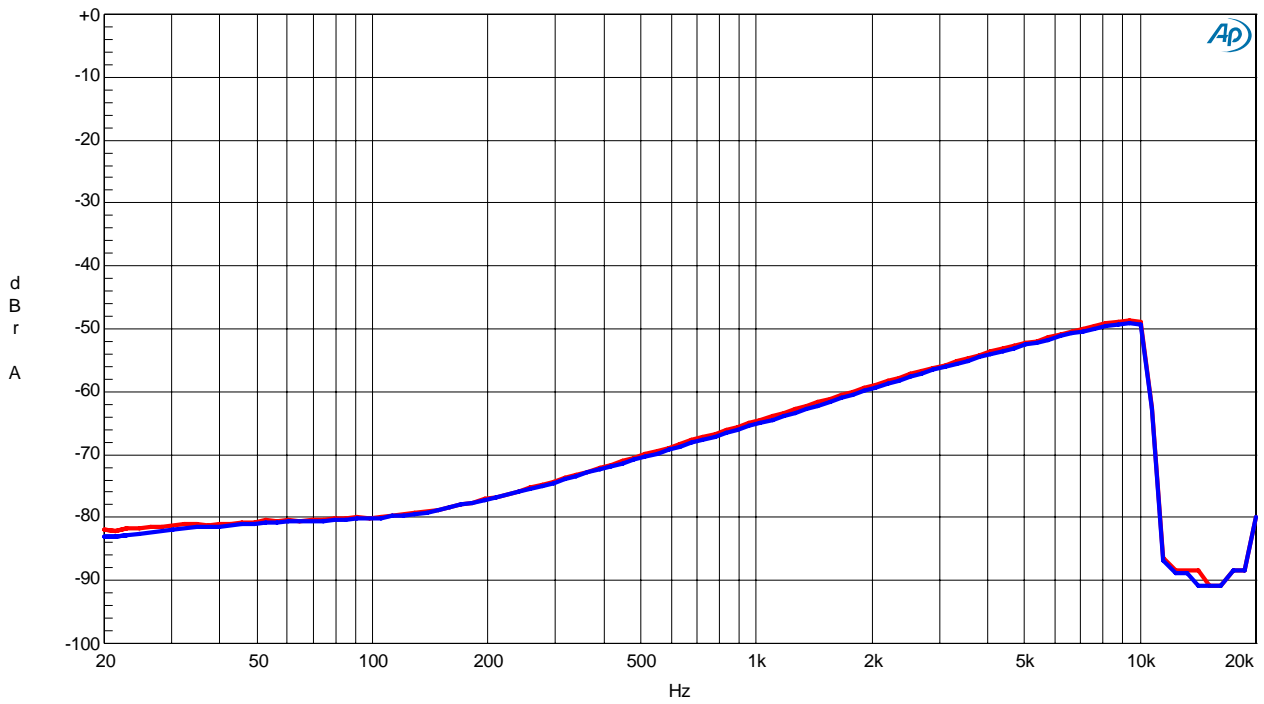

Figure 42. THD+N vs. Input Frequency

AK4645A DAC HPL/HPR Linearity
fs=44.1kHz,fin=1kHz

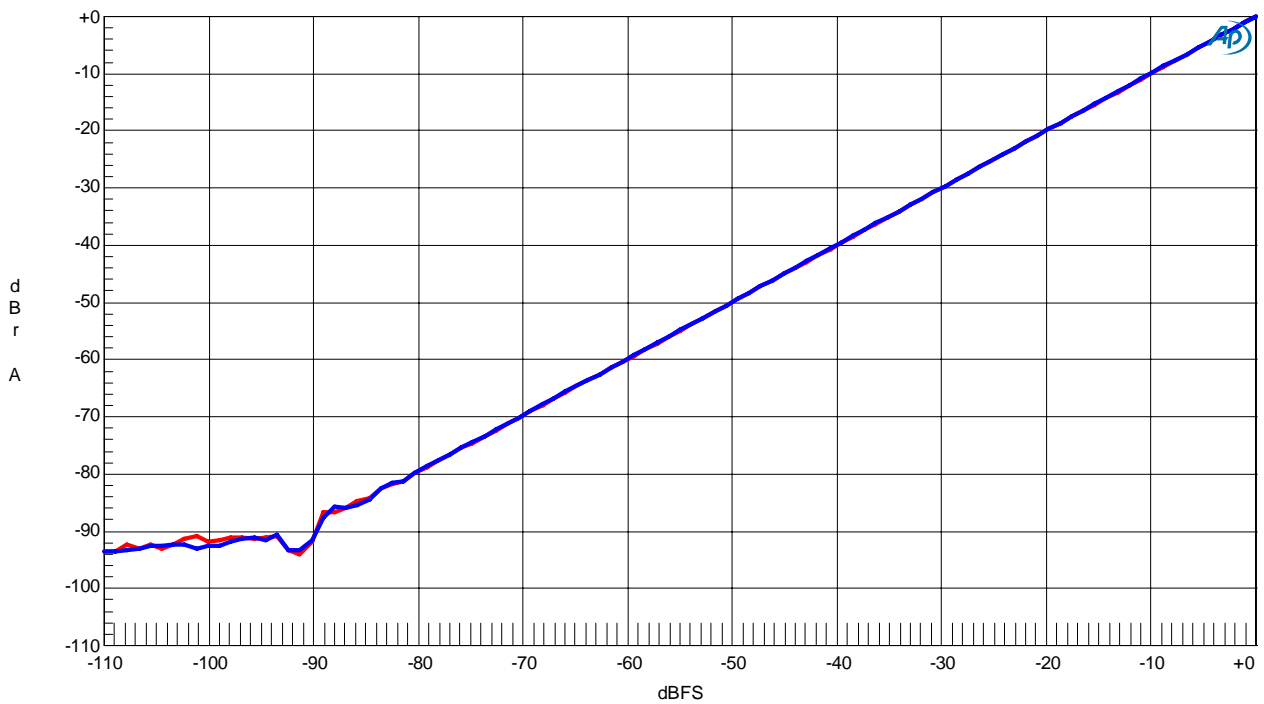
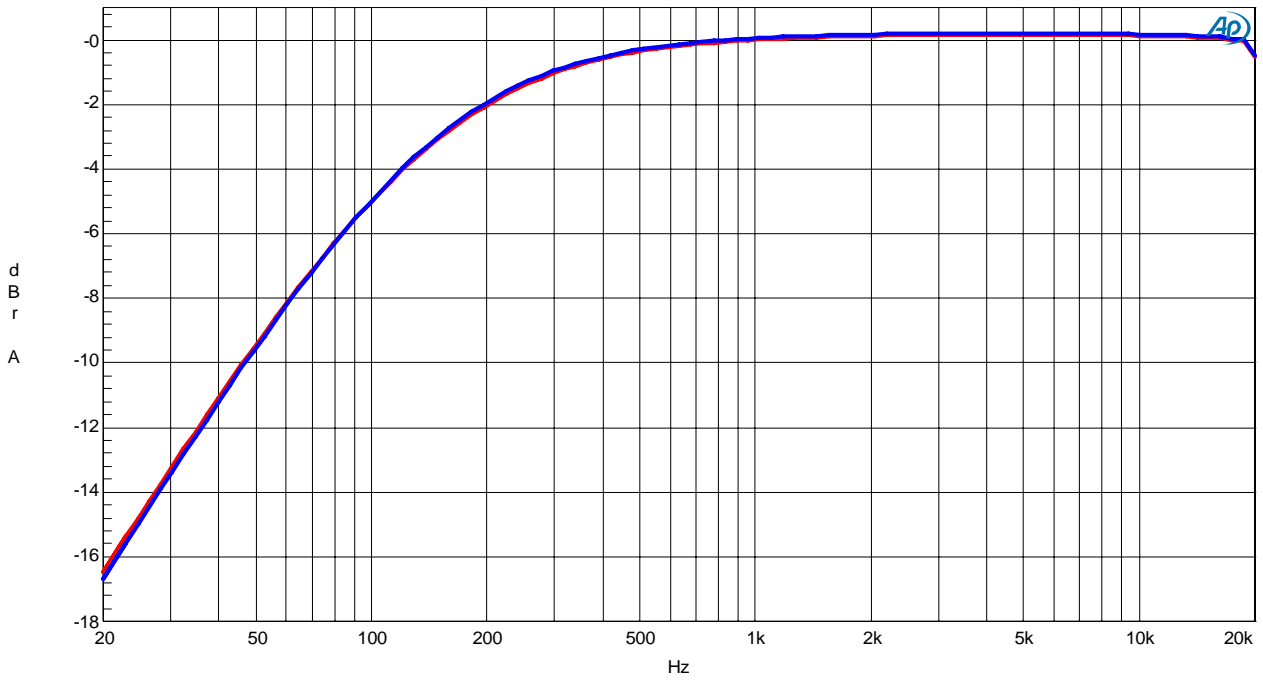

Figure 43. Linearity

AK4645A DAC HPL/HPR Frequency Response
fs=44.1kHz,0dB Input



*Cut-off frequency of HPF on board: 148.5Hz

Figure 44. Frequency Response

AK4645A DAC HPL/HPR Crosstalk
fs=44.1kHz,0dB Input

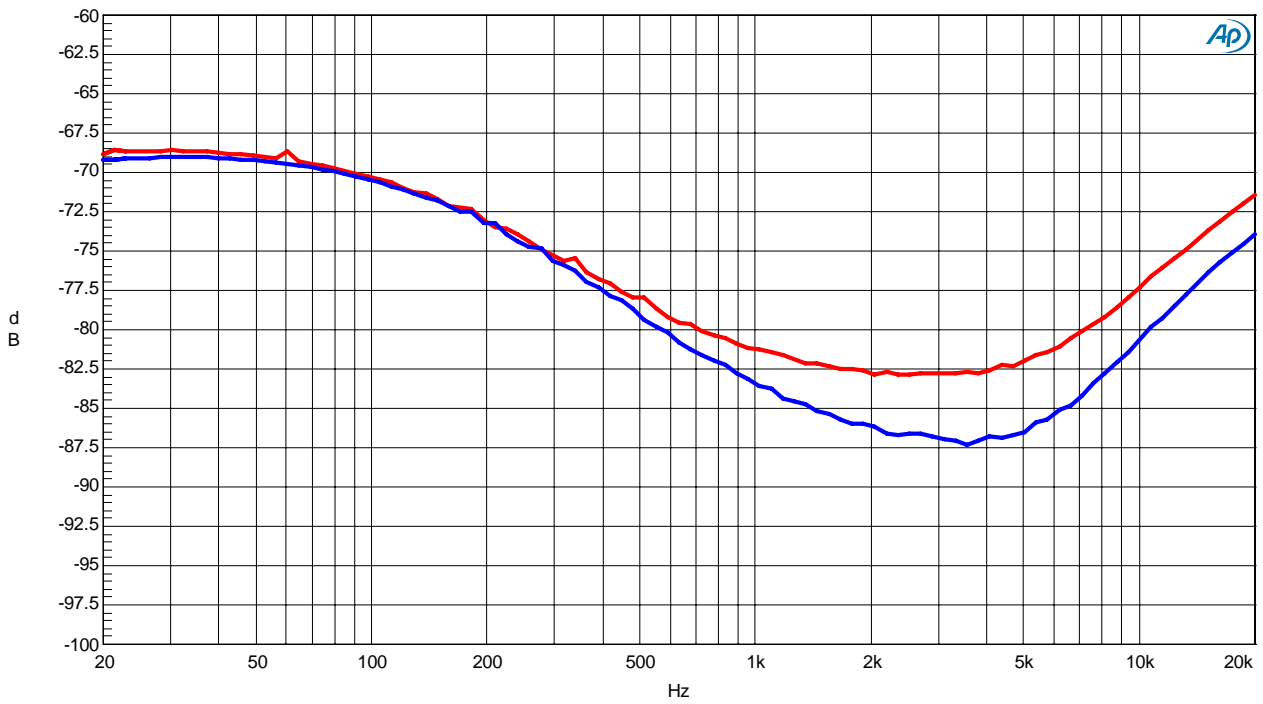
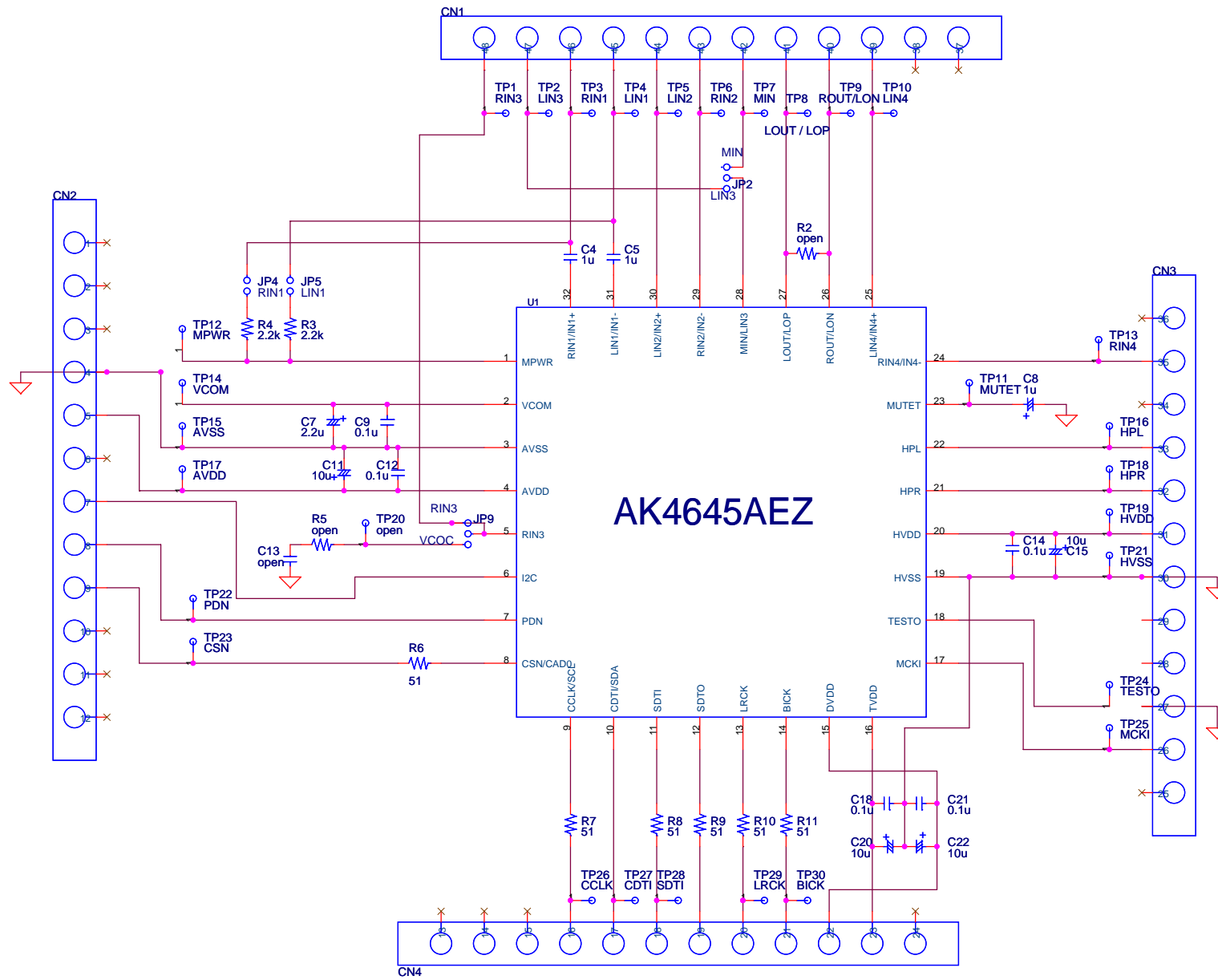

Figure 45. Crosstalk Plot

Revision History				
Date (YY/MM/DD)	Manual Revision	Board Revision	Reason	Contents
08/05/29	KM094900	0	First edition	
09/10/15	KM094901	1	Change	A block diagram was modified. Circuit diagram were changed. R5,C13,TP20:Open. Measurement results and Plots were updated. Default Jumper settings were changed.

IMPORTANT NOTICE

- These products and their specifications are subject to change without notice.
When you consider any use or application of these products, please make inquiries the sales office of Asahi Kasei Microdevices Corporation (AKM) or authorized distributors as to current status of the products.
- AKM assumes no liability for infringement of any patent, intellectual property, or other rights in the application or use of any information contained herein.
- Any export of these products, or devices or systems containing them, may require an export license or other official approval under the law and regulations of the country of export pertaining to customs and tariffs, currency exchange, or strategic materials.
- AKM products are neither intended nor authorized for use as critical components_{Note1}) in any safety, life support, or other hazard related device or system_{Note2}), and AKM assumes no responsibility for such use, except for the use approved with the express written consent by Representative Director of AKM. As used here:
 - Note1) A critical component is one whose failure to function or perform may reasonably be expected to result, whether directly or indirectly, in the loss of the safety or effectiveness of the device or system containing it, and which must therefore meet very high standards of performance and reliability.
 - Note2) A hazard related device or system is one designed or intended for life support or maintenance of safety or for applications in medicine, aerospace, nuclear energy, or other fields, in which its failure to function or perform may reasonably be expected to result in loss of life or in significant injury or damage to person or property.
- It is the responsibility of the buyer or distributor of AKM products, who distributes, disposes of, or otherwise places the product with a third party, to notify such third party in advance of the above content and conditions, and the buyer or distributor agrees to assume any and all responsibility and liability for and hold AKM harmless from any and all claims arising from the use of said product in the absence of such notification.



Title			AKD4645AEZ_SUB_32QFN		
Size	Document Number	AK4645AEZ			Rev
A3					0
Date:	Monday, August 31, 2009	Sheet	1	of	1

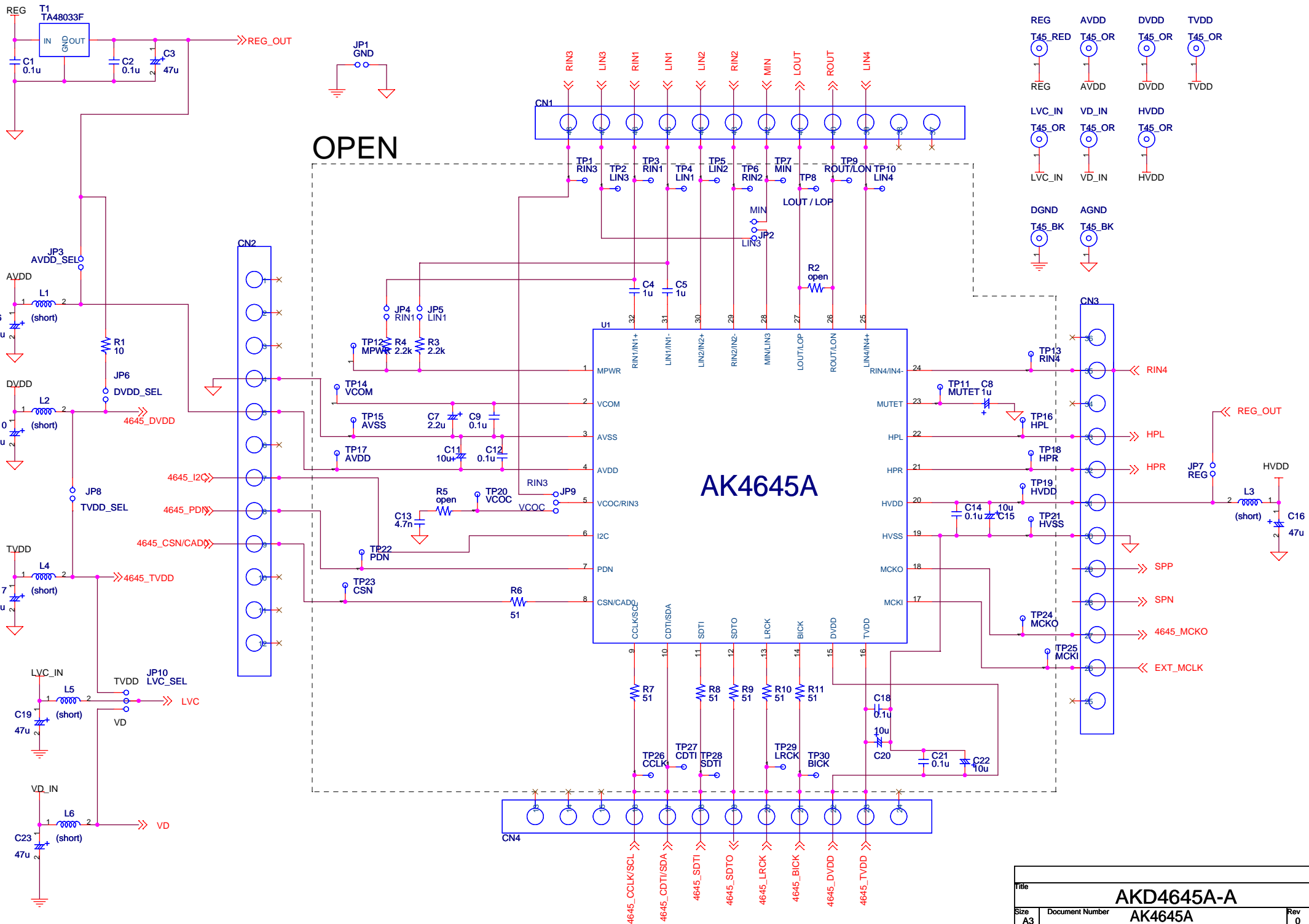

File		
AKD4645A-A		
Size A3	Document Number AK4645A	Rev 0
Date: Monday, August 31, 2009	Sheet 1	of 5

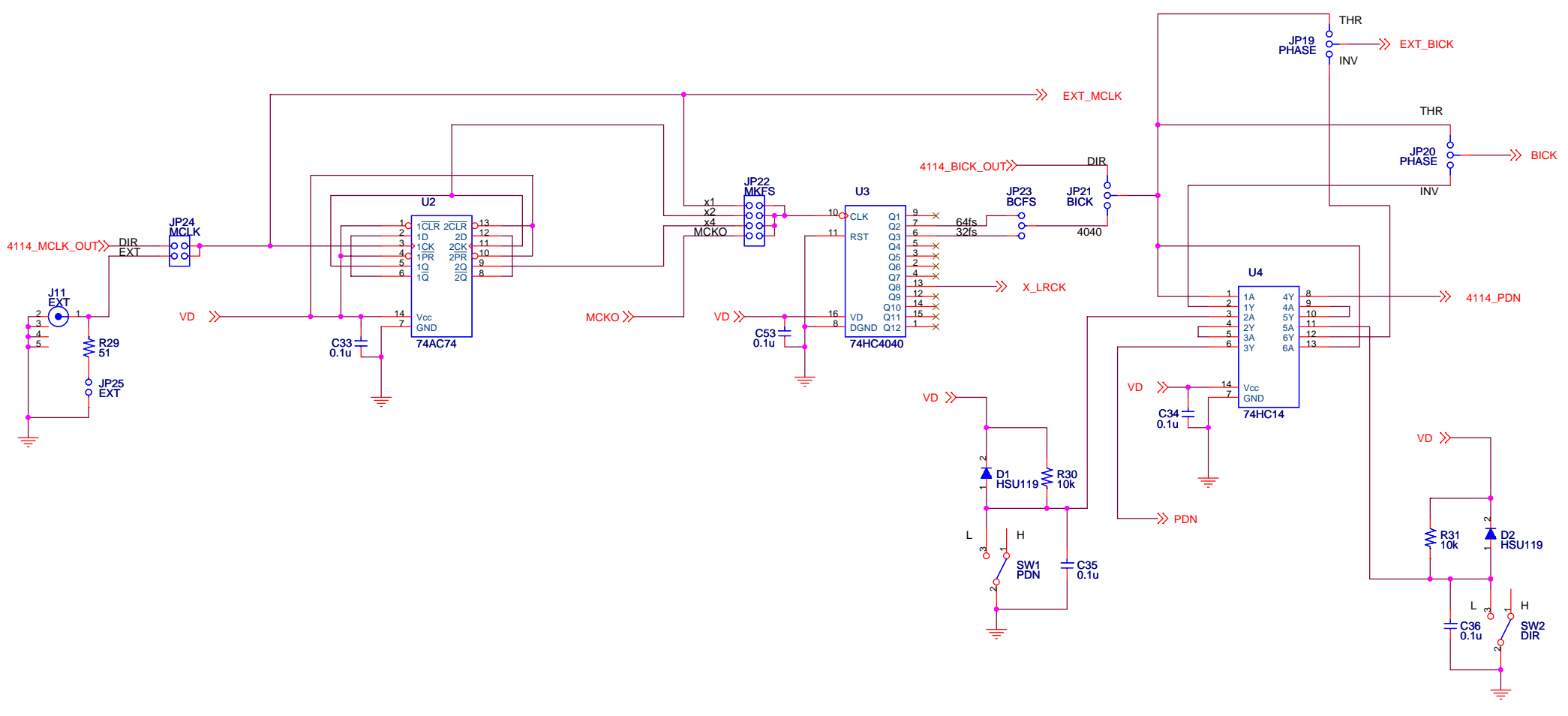

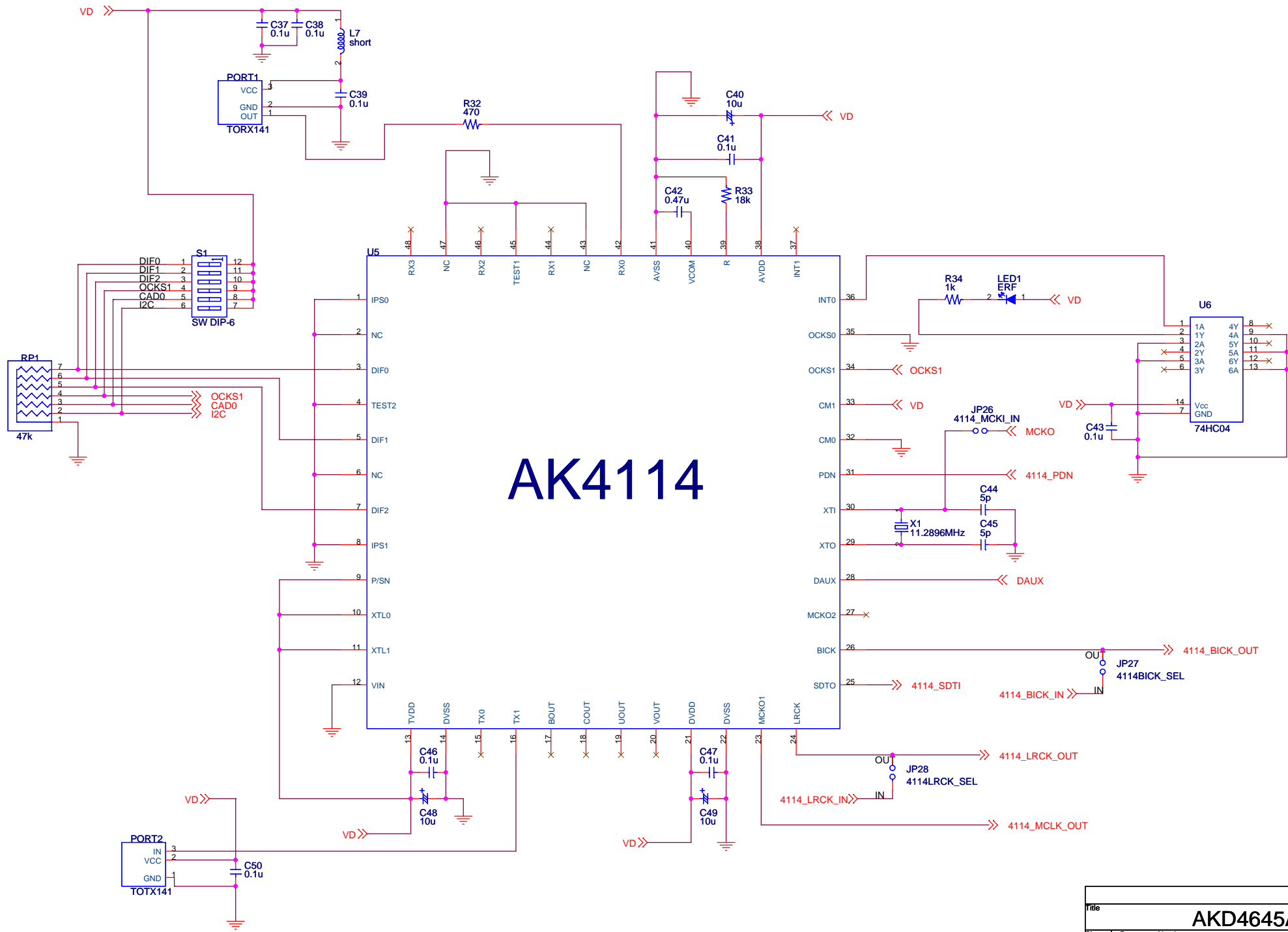

AK4114

File			AKD4645A-A	
Size	Document Number		DIR/DIT	
A3			Rev 0	
Date:	Monday, August 31, 2009	Sheet	4	of 5

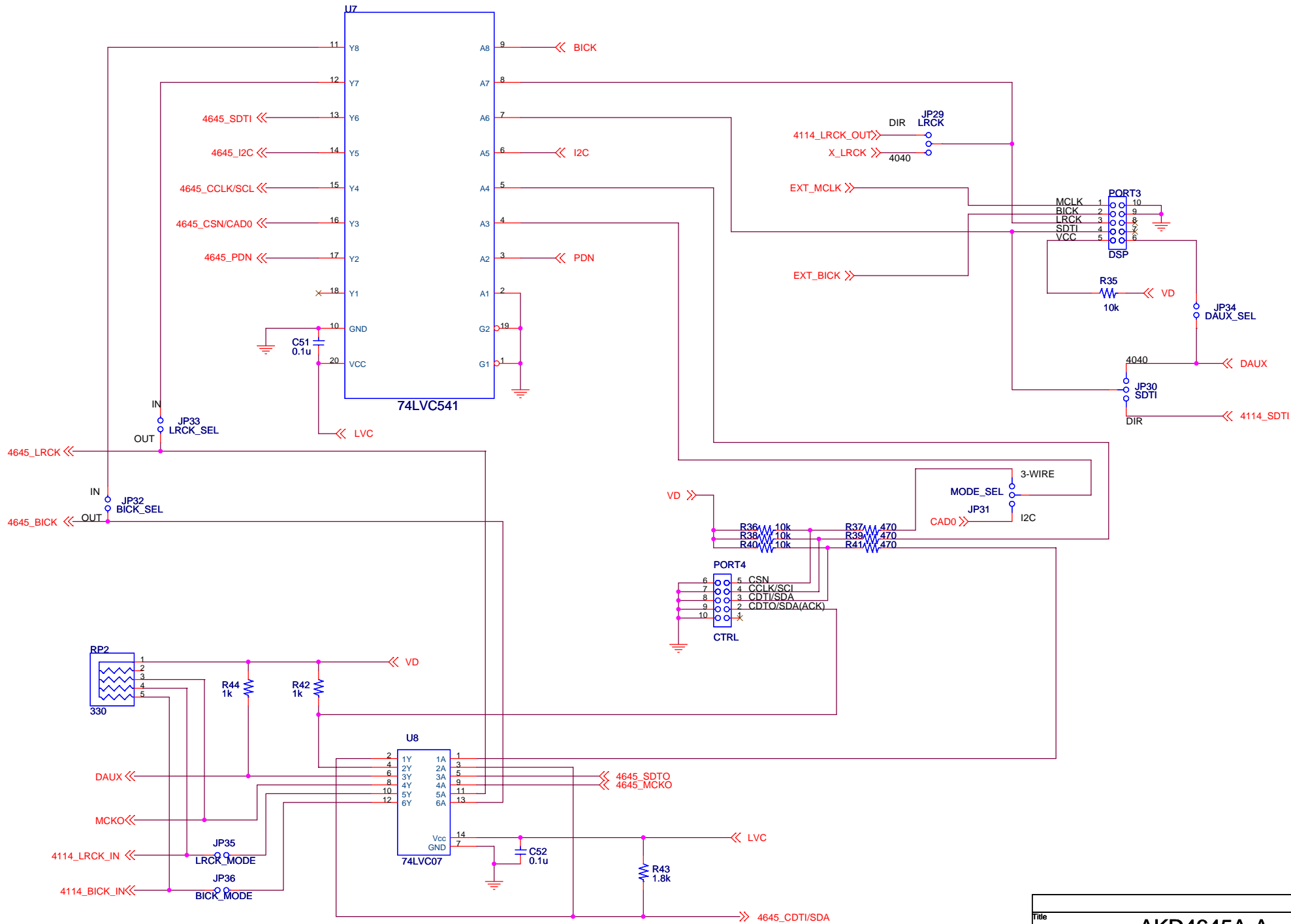

Title			AKD4645A-A		
Size	Document Number	LOGIC			Rev
A3					0
Date:	Friday, August 28, 2009	Sheet	5	of	5

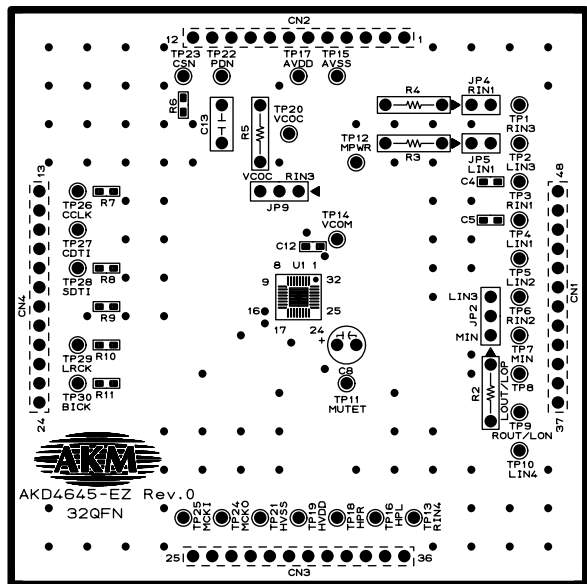

AKD4645-EZ SUB 32QFN L1 SILK

VKD4r2-E3 2NB 350FN L3 21LK

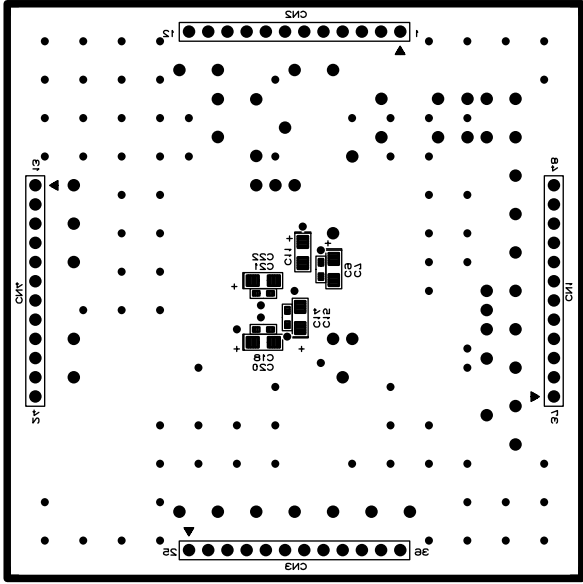

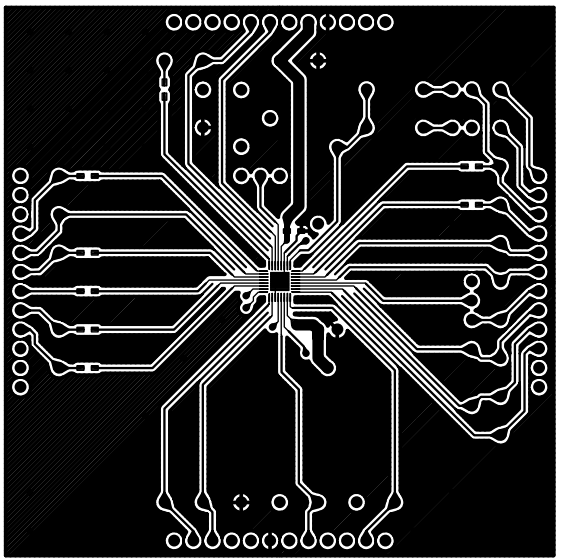

AKD4645-EZ SUB 32QFN L1

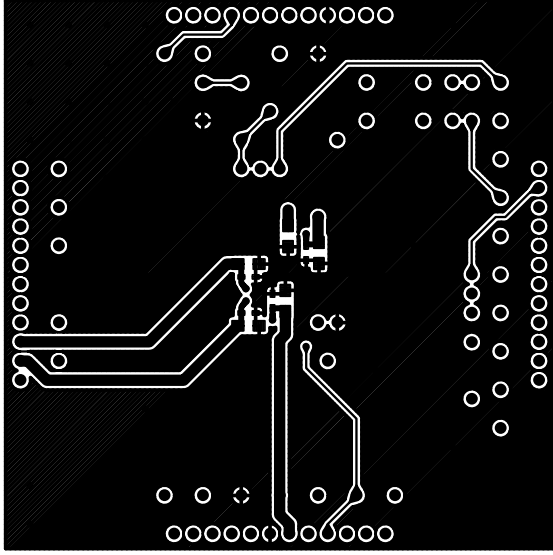

AKD942-EZ SUB 350FN L2



AKD4645-A Rev.0
Evaluation Board

