



AKD4392-SB

AK4392 Sound quality evaluation board Rev.0

General Description

AKD4392-SB is an evaluation board for AK4392 corresponding to DVD-Audio, which is 32Bit DAC. The AKD4392-SB includes a LPF which can add differential analog outputs from the AK4392 and also has a digital interface. Therefore, it is easy to evaluate sound quality of the AK4392.

■ Ordering Guide

AKD4392-SB --- Sound quality evaluation board for AK4392

Function

- On-board Analog output buffer circuit
- On-board digital audio interface. (AK4115)

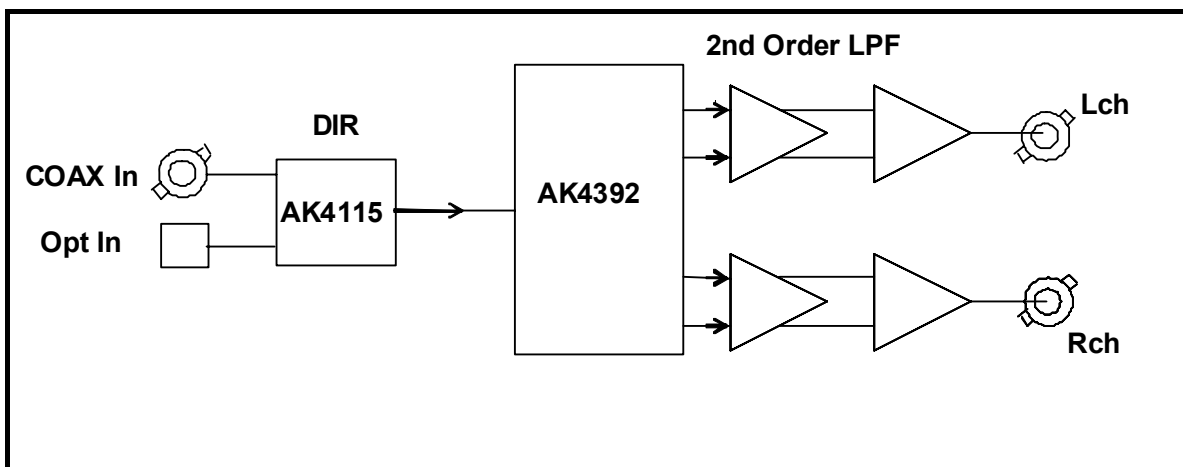

Figure 1. Block diagram

* Circuit diagram are attached at the end of this manual.

COAX is recommended for an evaluation of the Sound quality.

■ Operation sequence

1) Set up the power supply lines. (See “Other jumpers set-up”.)

Name	Color	Voltage	Comments	Attention
+15V	Red	+12~+15V	Regulator, Power supply for Op-amp.	This jack is always needed. Power line
-15V	Blue	-12~-15V	Power supply for Op-amp.	This jack is always needed. Power line
AGND	Black	0V	GND	This jack is always needed.

Table 1. Set up of power supply lines

Each supply line should be distributed from the power supply unit.

2) Set-up the jumper pins

3) Set-up the DIP switches. (See the followings.)

4) Power on

The AK4392 should be reset once bringing SW3 (PDN) “L” upon power-up.

■ Evaluation mode

1. DIR(COAX) (default)

The DIR generates MCLK, BICK and LRCK SDATA from the received data through BNC connector (J7). It is possible for the evaluation using such as CD test disk.

Setting: R87 = open; R88 = short (0Ω)

COAX is recommended for an evaluation of the Sound quality.

2. DIR(Optical)

The DIR generates MCLK, BICK and LRCK SDATA from the received data through Optical connector (PORT2). It is possible for the evaluation using such as CD test disk.

Setting: R87 = short (0Ω); R88 = open

3. All clocks are fed through the PORT1.

Setting:

-R54, R55, R56, R58 = open

-R50, R51, R52 = 100Ω; R53 = 5.1Ω

■ DIP Switch setting

[SW1]: AK4115 setting

No.	Pin	L	H	Default
1	OCKS1	Master Clock setting of AK4115		H
2	OCKS0	Refer to Table 4		L

Table 2. SW1 setting

[SW2]: AK4392 setting

No.	Pin	L	H	Default
1	-	-	-	-
2	P/S	Serial mode	Parallel mode	L

Table 3. SW2 setting

The frequency of the master clock output is set by OCKS0 and OCKS1 as shown in Table 4.

OCKS1	OCKS0	MCLK Frequency
L	L	256fs @fs=88.2/96kHz
H	L	512fs @fs=32/44.1/48kHz
H	H	128fs @fs=176.4/192kHz

(Default)

Table 4. MCLK Clock

■ SW3 setting

[SW3](PDN): Reset of AK4392. Select "H" during operation.

■ External Analog Circuit

The differential output circuit and LPF is implemented on board. The differential outputs of AK4392 is buffered by non-inverted circuit(2nd order LPF, fc=106.4k, Q=0.698, G=+3.9dB). LPF adds differential outputs(1st order LPF, fc=284k, G=-0.84dB). LME49710NA is used for op-amp on this board that has low noise and high voltage torelance characteristics. Analog signal is output via BNC connectors on the board. The output level is about 2.8Vrms (typ@VREF=5.0V) by BNC.

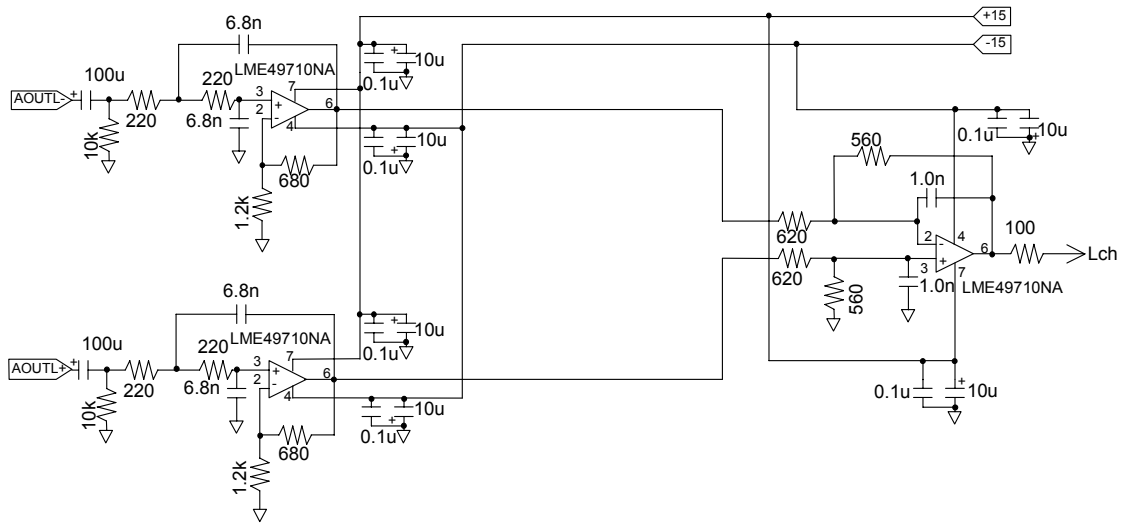

Figure 2. External Analog Filter

AKD4392-SB Filter	40kHz (Double)	80kHz (quad)
Internal Filter	-0.3dB	-1dB
External LPF	-0.12dB	-1.3dB
Total	-0.42dB	-2.3dB

This table shows typical value.

Table 5. Frequency Responses

Control Software Manual

■ Evaluation Board and Control Soft Settings

1. Set an evaluation board properly.
2. Connect the evaluation board to an IBM PC/AT compatible PC by a 10wire flat cable. Be aware of the direction of the 10pin header. When running this control soft on the Windows 2000/XP, the driver which is included in the CD must be installed. Refer to the "Driver Control Install Manual for AKM Device Control Software" for installing the driver. When running this control soft on the windows 95/98/ME, driver installing is not necessary. This control soft does not support the Windows NT.
3. Proceed evaluation by following the process below.