



# Low Suprious Multiclock Generator for Audio **AK8133**

## Features

- 27MHz Crystal Input or External Input
- Four Frequency-Selectable Clock Outputs
- One 27MHz-Reference Output
- Selectable Clock out Frequencies:
  - CLK1: 24.576,36.864MHz
  - CLK2: 4.096,8.192,11.2896,12.288,16.384  
22.5792,24.576,49.152MHz
  - CLK3: 8.4672,12.288,16.9344,18.432  
24.576,33.8688,36.864,73.728MHz
  - CLK4: 16.9344,33.8688MHz
- Built-in XO
- Low Jitter Performance
  - Period Jitter:  
30 psec (Typ.) at CLK1-4
- Low Current Consumption:  
18.0mA (Typ.) at 3.3V
- Supply Voltage:  
2.85V to 3.6V
- Operating Temperature Range:  
-40°C to +85°C
- Package:  
16-pin SSOP (Lead free)

## Description

The AK8133 is a member of AKEMD's low power multi clock generator family designed for a high quality audio cock with high performance C/N. The AK8133 generates different frequency clocks from a 27MHz crystal oscillator or external 27MHz clock input. It provides them to up to four outputs configured by pin-setting. Both circuitries of XO and PLL in AK8133 are derived from AKEMD's long-term-experienced clock device technology, and enable clock output to perform low jitter and to operate with very low current consumption. The AK8133 is available in a 16-pin SSOP package.

## Applications

- Personal Video Recorders
- Set-Top-Boxes
- Multi Media Receivers

## Block Diagram

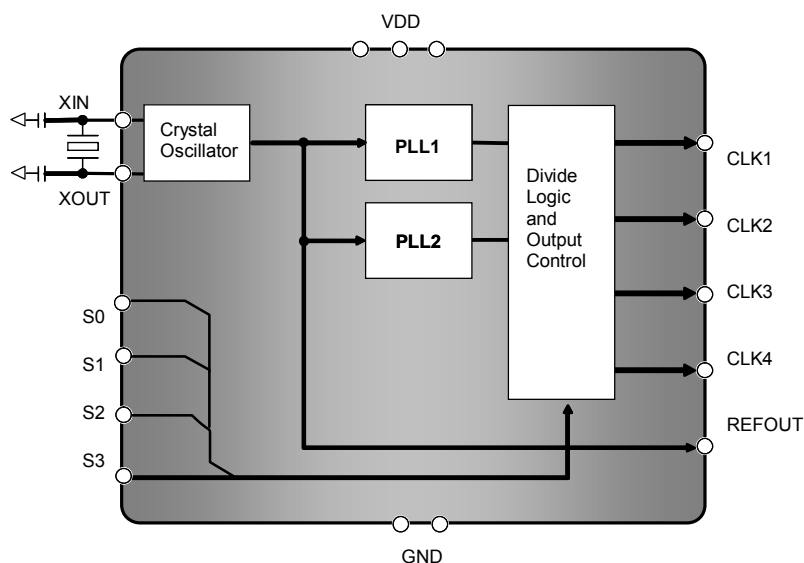

**AK8133 Multi Clock Generator**

**Pin Descriptions**

**Package: 16-Pin SSOP(Top View)**

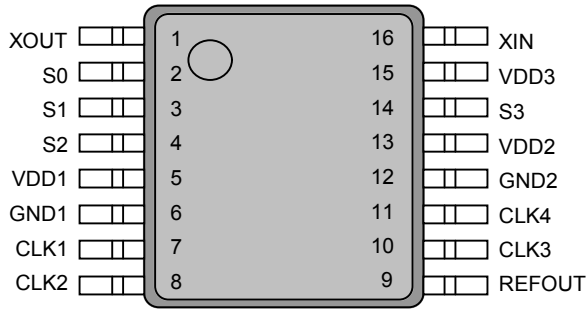

Pin No.	Pin Name	Pin Type	Description
1	XOUT	OUT	Crystal connection, Connect to 27.000MHz crystal Please open when an external clock input is used
2	S0	IN	Clock Out Frequency select 0, See Table 2 for the selection (1)
3	S1	IN	Clock Out Frequency select 1, See Table 2 for the selection (1)
4	S2	IN	Clock Out Frequency select 2, See Table 2 for the selection
5	VDD1	--	Power Supply 1
6	GND1	--	Ground 1
7	CLK1	OUT	Clock output 1, See Table 1 for its selectable frequency
8	CLK2	OUT	Clock output 2, See Table 2 for its selectable frequency
9	REFOUT	OUT	Reference Clock Output of 27.000MHz Crystal or external clock
10	CLK3	OUT	Clock output 3, See Table 2 for its selectable frequency
11	CLK4	OUT	Clock output 4, See Table 2 for its selectable frequency
12	GND2	--	Ground 2
13	VDD2	--	Power Supply 2
14	S3	IN	Clock Out Frequency select 1, See Table 1 for the selection (1)
15	VDD3	--	Power Supply 3
16	XIN	IN	Crystal connection, Connect to 27.000MHz crystal Or external clock input (minimum 1Vpp input). Input becomes binary after passing an internal HPF. Input Resistance is 37.5k-ohm.

(1) Internal pull up 360kΩ

**Ordering Information**

Part Number	Marking	Shipping Packaging	Package	Temperature Range
AK8133V	8133V	Tape and Reel	16-pin SSOP	-40 to 85 °C
AK8133E	8133E	Tape and Reel	16-pin SSOP	-20 to 85 °C

## Absolute Maximum Rating

Over operating free-air temperature range unless otherwise noted <sup>(1)</sup>

Items	Symbol	Ratings	Unit
Supply voltage	VDD	-0.3 to 4.6	V
Input voltage	V <sub>in</sub>	VSS-0.3 to VDD+0.3	V
Input current (any pins except supplies)	I <sub>IN</sub>	±10	mA
Storage temperature	T <sub>stg</sub>	-55 to 130	°C

Note

(1) Stress beyond those listed under "Absolute Maximum Ratings" may cause permanent damage to the device. These are stress ratings only. Functional operation of the device at these or any other conditions beyond those indicated under "Recommended Operating Conditions" is not implied. Exposure to absolute-maximum-rating conditions for extended periods may affect device reliability. Electrical parameters are guaranteed only over the recommended operating temperature range.



### ESD Sensitive Device

This device is manufactured on a CMOS process, therefore, generically susceptible to damage by excessive static voltage. Failure to observe proper handling and installation procedures can cause damage. AKEMD recommends that this device is handled with appropriate precautions.

## Recommended Operation Conditions

Parameter	Symbol	Conditions	Min	Typ	Max	Unit
Operating temperature	Ta1	AK8133V	-40		85	°C
	Ta2	AK8133E	-20		85	°C
Supply voltage <sup>(1)</sup>	VDD		2.85	3.3	3.6	V
Output Load Capacitance	Cp1	Pin: CLK1-4			15	pF
	Cp2	Pin: REFOUT			25	pF

Note:

(1) Power to VDD1, VDD2 and VDD3 requires to be supplied from a single source. A decoupling capacitor of 0.1μF for power supply line should be installed close to each VDD pin.

## DC Characteristics

All specifications at VDD: over 2.85 to 3.6V, Ta=Ta1(AK8133V), Ta=Ta2(AK8133E)

Parameter	Symbol	Conditions	MIN	TYP	MAX	Unit
High level input voltage	$V_{IH}$	Pin: S0,S1,S2,S3	0.7VDD			V
Low level input voltage	$V_{IL}$	Pin: S0,S1,S2,S3			0.3VDD	V
Input leak current 1	$I_{L1}$	Pin: S0,S1,S3	-20		+10	$\mu$ A
Input leak current 2	$I_{L2}$	Pin: S2	-10		+10	$\mu$ A
High Level output voltage	$V_{OH}$	Pin: CLK1-4, REFOUT $I_{OH}=-4$ mA	0.8VDD			V
Low level output Voltage	$V_{OL}$	Pin: CLK1-4, REFOUT $I_{OL}=+4$ mA			0.2VDD	V
Current consumption	$I_{DD}$	No load Clock out selection by note Ta=25°C		18.0		mA

## AC Characteristics

All specifications at VDD: over 2.85 to 3.6V, Ta=Ta1(AK8133V), Ta=Ta2(AK8133E) unless otherwise noted

Parameter	Symbol	Conditions	MIN	TYP	MAX	Unit
Crystal clock frequency		Pin: XIN, XOUT	26.9	27.0000	27.1	MHz
External clock frequency		Pin: XIN <sup>(1)</sup>	26.9	27.0000	27.1	MHz
Period jitter <sup>(3)</sup>		Pin: CLK1-4, REFOUT		30		ps
Output Clock duty Cycle		Pin: CLK1-4 <sup>(2)</sup>	45	50	55	%
		Pin: REFOUT <sup>(3)</sup>	40	50	60	%
Output clock rise time	$t_{rise}$	Pin: CLK1-4 <sup>(2)</sup> , REFOUT <sup>(3)</sup>		2.5		ns
Output clock fall time	$t_{fall}$	Pin: CLK1-4 <sup>(2)</sup> , REFOUT <sup>(3)</sup>		2.5		ns
Output Lock Time <sup>(4)</sup>		Pin: CLK1-4 <sup>(2)</sup>		5		ms

(1) Amplitude is 1Vpp or more.

(2) Measured with load capacitance of 15pF

(3) Measured with load capacitance of 25pF

(4)  $1\sigma$  in 1000 sampling or more

(5) The time that output reaches the target frequency within accuracy of  $\pm 0.1\%$  from the point that the power supply reaches VDD.

## Output clock frequency selection

The AK8133 generates a range of low-jitter and high-accuracy clock frequencies with two built-in PLLs and provides to up to four assigned outputs. A frequency selection at assigned output pin is configured by pin-setting of S0 (Pin2), S1 (Pin3), S2(Pin4) and S3 (Pin14). The selectable frequency is shown in Table 2 and Table2.

Selection Pin	Output Frequency(MHz)
<b>S3(Pin14)</b>	<b>CLK1(Pin 7)</b>
L	36.864
H	24.576

**Table 1: CLK1 Clock output Frequency**

Sampling Frequency (kHz)	Selection Pin			Clock Output Frequency (MHz)		
	S2 (Pin 4)	S1 (Pin 3)	S0 (Pin 2)	CLK2 256fs (Pin 8)	CLK3 384fs (Pin 10)	CLK4 (Pin 11)
48.0	L	L	L	12.288	18.432	33.8688
44.1	L	L	H	11.2896	16.9344	33.8688
32.0	L	H	L	8.192	12.288	33.8688
192.0	L	H	H	49.152	73.728	33.8688
88.2	H	L	L	22.5792	33.8688	33.8688
96.0	H	L	H	24.576	36.864	33.8688
64.0	H	H	L	16.384	24.576	33.8688
16.0/22.05	H	H	H	4.096	8.4672	16.9344

**Table 2: CLK2-4 Clock output Frequency**

**Typical Connection Diagram**

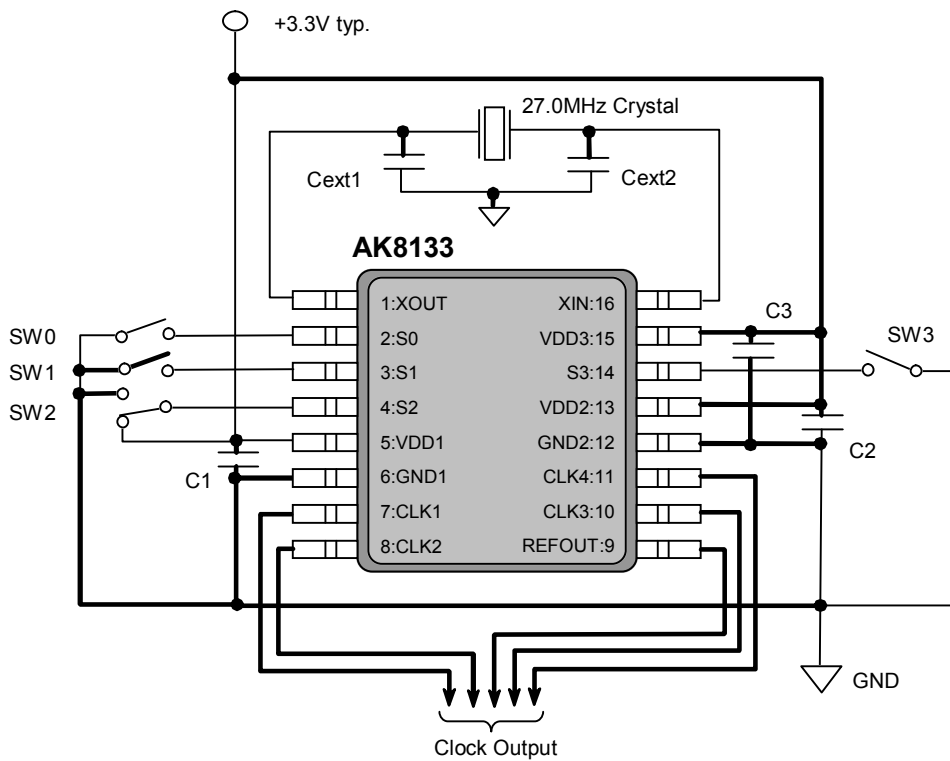

A: Crystal connection

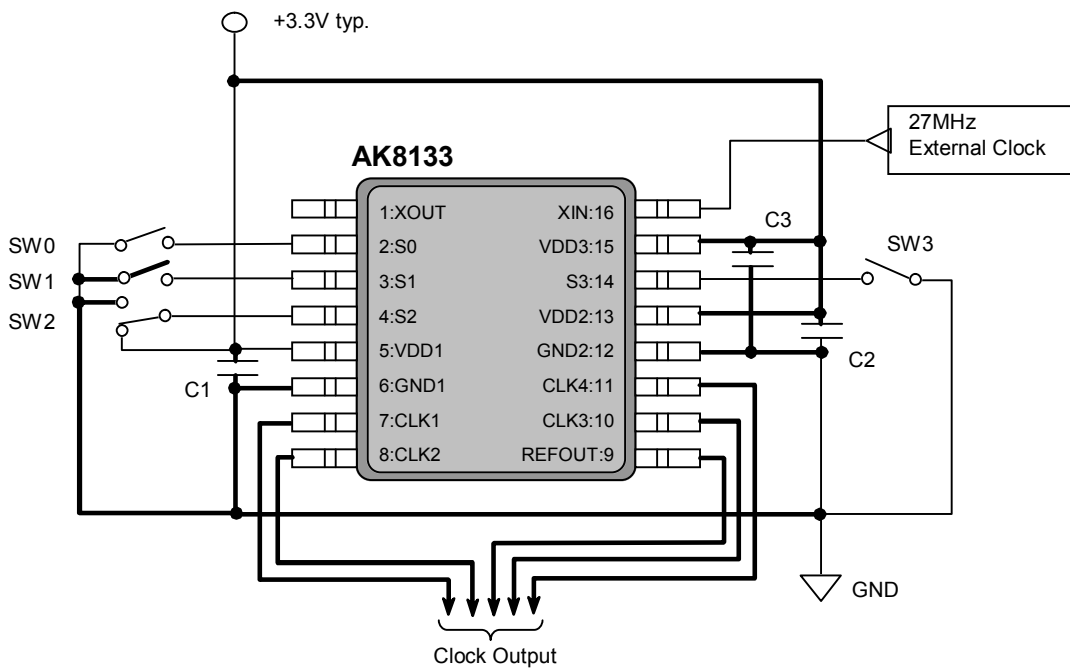

B: External clock input

**Figure 1: Typical Connection Diagram**

C1-3 : 0.1µF

Cext1-2 : Depends on crystal characteristics. Refer the specification of the crystal.

Sw0-3 : Open is "H" and tied to GND is "L" for S0,S1and S3, because these pins have internal pull up resistor. For S2 tied VDD is "H" and tied GND is "L" .

## PCB Layout Consideration

The AK8133 is a high-accuracy and low-jitter multi clock generator. For proper performances specified in this datasheet, careful PCB layout should be taken. The followings are layout guidelines based on the typical connection diagram shown in Figure 1

**Power supply line** – AK8133 has three power supply pins (VDD1-3) which deliver power to internal circuitry segments. A 0.1 $\mu$ F decoupling capacitor should be placed as close to each VDD pin as possible.

**Ground pin connection** – AK8133 has two ground pins (GND1-2). These pin require connecting to plane ground which will eliminate any common impedance with other critical switching signal return. 0.1 $\mu$ F decoupling capacitors placed at VDD1, VDD2, and VDD3 should be grounded at close to the GND1 pin, the GND2 pin, and the GND2, respectively.

**Crystal connection** – Proper oscillation performance are susceptible to stray or parasitic capacitors around crystal. The wiring traces to a crystal form X1 (Pin 1) and X2 (Pin 14) have equal lengths with no via and as short in length as possible. These traces should be also located away from any traces with switching signal.

**Package Information**

• **Mechanical data**

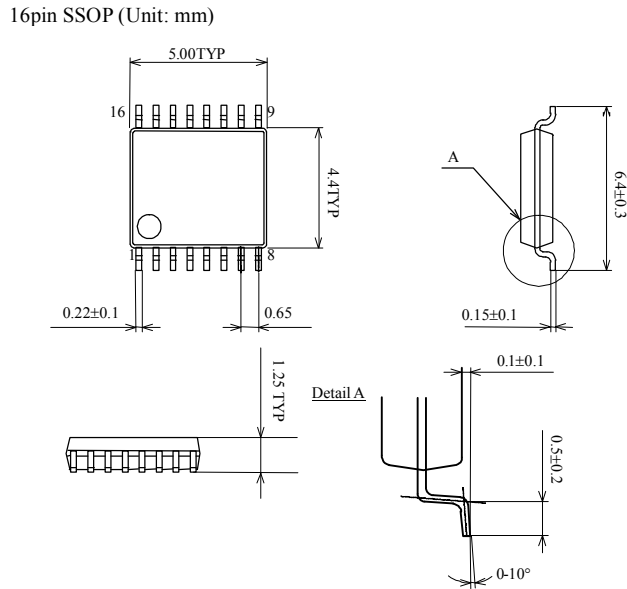

• **Marking**

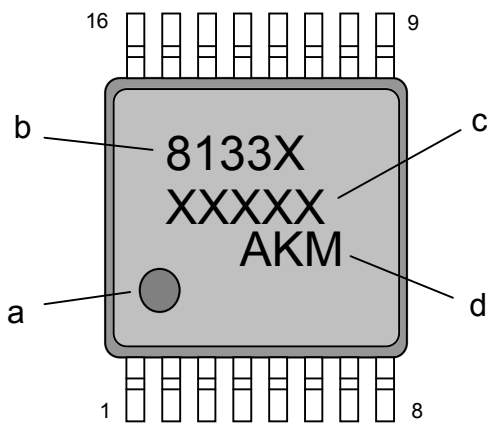

- a: #1 Pin Index
- b: Part number  
"X" is "V" for AK8133V  
"X" is "E" for AK8133E
- c: Date code (5 digits)
- d: Product Family Logo <sup>(1)</sup>

(1) **AKM** is the brand name of AKEMD's IC's.

**AKM** and the logo - - are the brand of AKEMD's IC's and identify that AKEMD continues to offer the best choice for high performance mixed-signal solution under this brand.

• **RoHS Compliance**



All integrated circuits from Asahi Kasei EMD Corporation (AKEMD) assembled in "lead-free" packages\* are fully compliant with RoHS.

(\*) RoHS compliant products from AKEMD are identified with "Pb free" letter indication on product label posted on the anti-shield bag and boxes.



This page is intentionally blank.

## IMPORTANT NOTICE

- These products and their specifications are subject to change without notice.  
When you consider any use or application of these products, please make inquiries the sales office of Asahi Kasei EMD Corporation (AKEMD) or authorized distributors as to current status of the products.
- AKEMD assumes no liability for infringement of any patent, intellectual property, or other rights in the application or use of any information contained herein.
- Any export of these products, or devices or systems containing them, may require an export license or other official approval under the law and regulations of the country of export pertaining to customs and tariffs, currency exchange, or strategic materials.
- AKEMD products are neither intended nor authorized for use as critical components<sup>Note1)</sup> in any safety, life support, or other hazard related device or system<sup>Note2)</sup>, and AKEMD assumes no responsibility for such use, except for the use approved with the express written consent by Representative Director of AKEMD. As used here:
  - Note1) A critical component is one whose failure to function or perform may reasonably be expected to result, whether directly or indirectly, in the loss of the safety or effectiveness of the device or system containing it, and which must therefore meet very high standards of performance and reliability.
  - Note2) A hazard related device or system is one designed or intended for life support or maintenance of safety or for applications in medicine, aerospace, nuclear energy, or other fields, in which its failure to function or perform may reasonably be expected to result in loss of life or in significant injury or damage to person or property.
- It is the responsibility of the buyer or distributor of AKEMD products, who distributes, disposes of, or otherwise places the product with a third party, to notify such third party in advance of the above content and conditions, and the buyer or distributor agrees to assume any and all responsibility and liability for and hold AKEMD harmless from any and all claims arising from the use of said product in the absence of such notification.