

AsahiKASEI
ASAHI KASEI EMD**AK7752****Audio/Hands Free DSP with Stereo CODEC****GENERAL DESCRIPTION**

The AK7752 is a digital signal processor with an integrated stereo CODEC. The digital signal processor (DSP) can execute a high-quality hands-free algorithm, using only internal memory. Fine tuning is available for improving voice quality of the hands-free function in actual user environments. The AK7752 includes delay RAM, an integrated PLL, four digital audio input and eight digital audio output ports. The AK7752 can perform pre and post processing for speech recognition, volume control adjustment and parametric equalization, executed by programs downloaded via the microprocessor interface.

FEATURES**[ADC Block]**

- Sampling rate: 8kHz ~ 48kHz
- 24-bit stereo
- S/(N+D): 86dB
- DR, S/N: 89dB (fs=8 kHz), 91dB (fs=48kHz)
- Integrated DC offset canceling High Pass Filter

[DAC Block]

- Sampling rate: 8kHz ~ 48kHz
- 18-bit stereo
- S/(N+D): 90dB (fs =8kHz), 88dB (fs=48kHz)
- DR, S/N: 95dB (fs =8kHz), 95dB (fs=48kHz)

[Input/Output Digital Interface]

- 4-channel Serial Data Input
- 8-channel Serial Output

[General]

- Integrated PLL
- EEPROM (AK6514C) Interface
- Microprocessor Interface: I²C BUS or AKM original mode
- Power Supply: Single 3.3V ±0.3V
- Operating Temperature Range: -40°C~85°C
- 64pin LQFP

BLOCK DIAGRAM

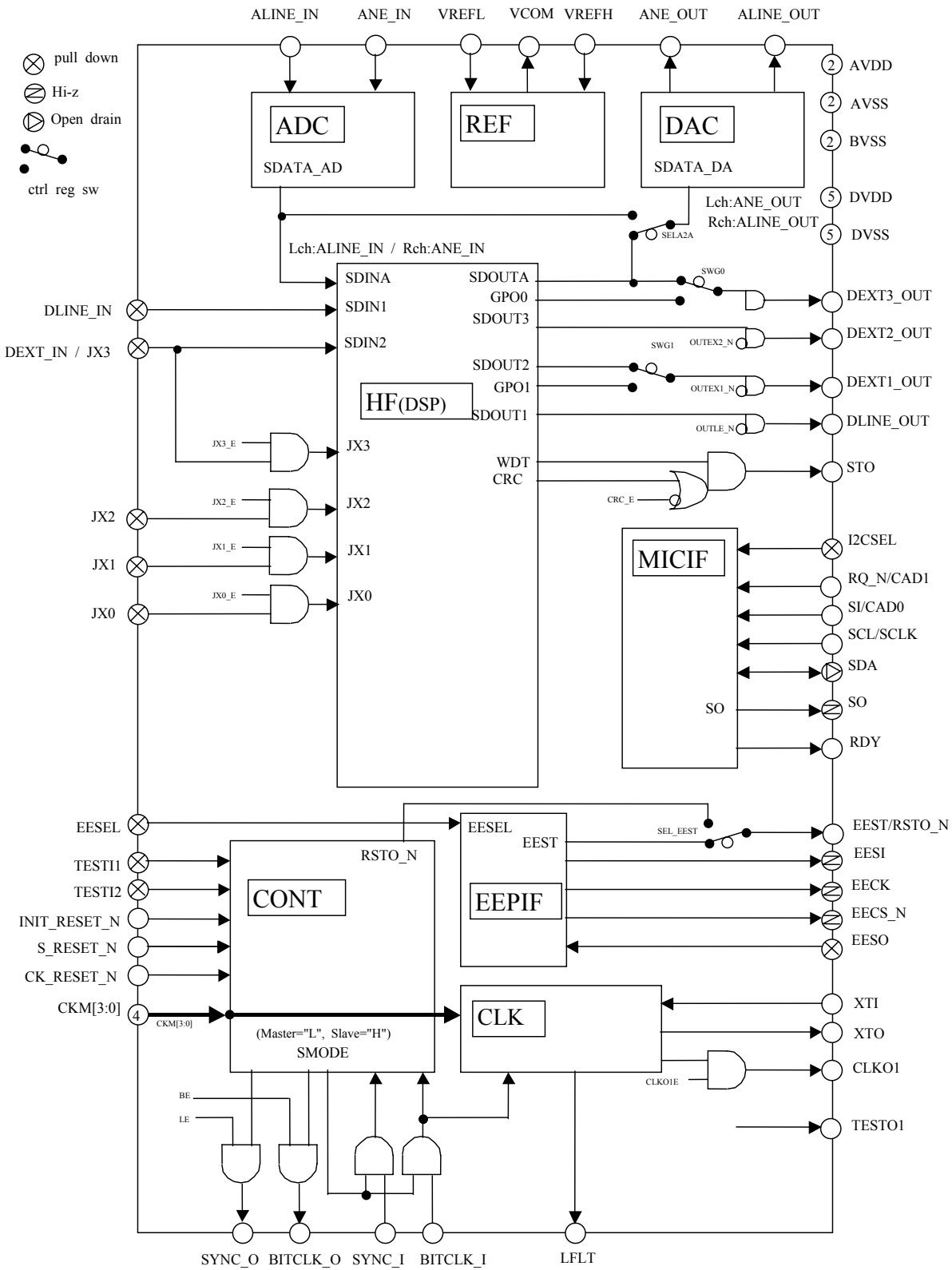


Figure 1. Block Diagram

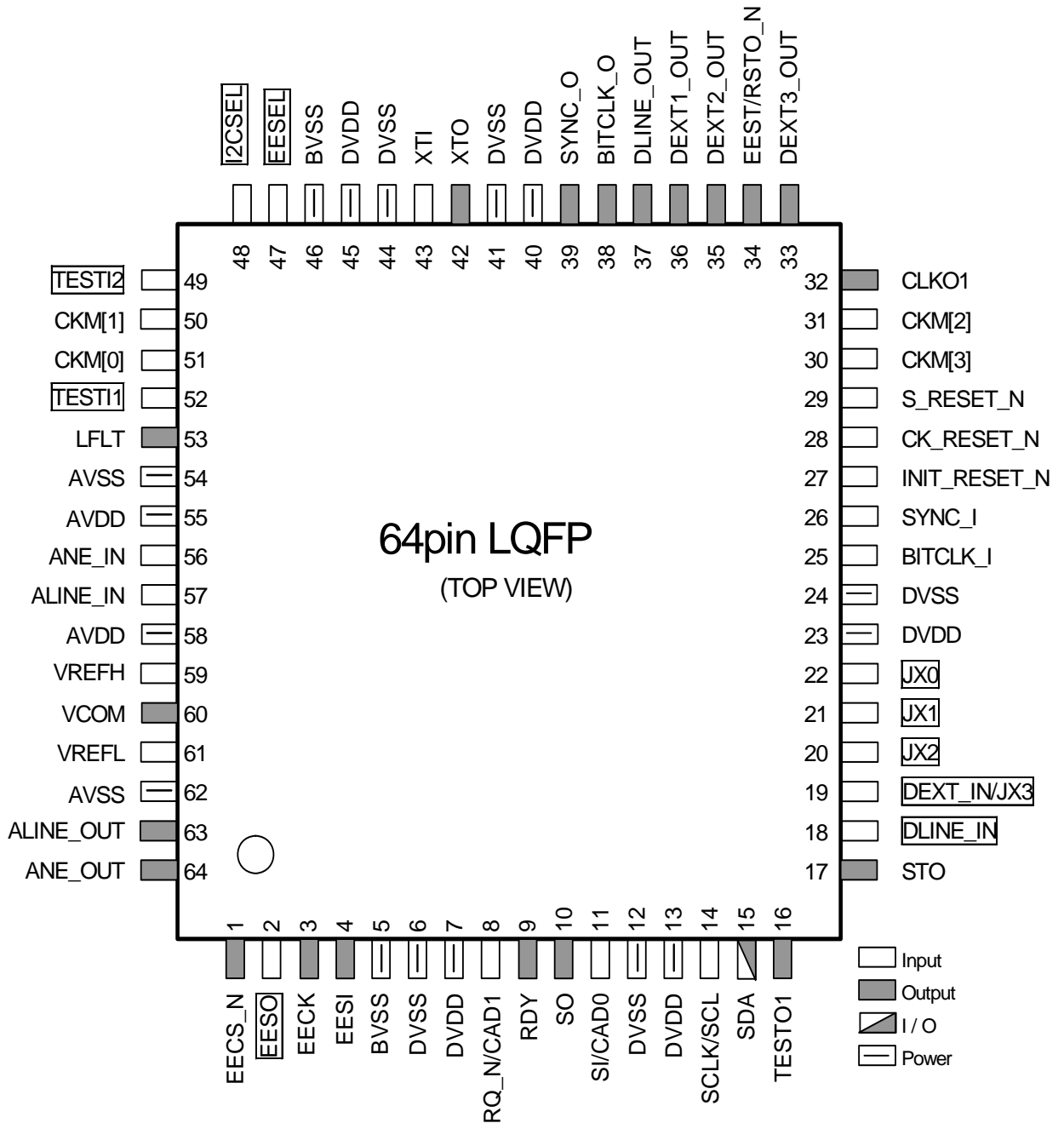
* Figure 1 shows a simplified diagram of the AK7752, which isn't the perfect same as the actual circuit diagram.

■ Ordering Guide

 AK7752VQ
 AKD7752

 -40 ~ +85°C 64pin LQFP
 Evaluation Board for AK7752

■ Pin Layout



Note) XXXX is internal pull-down pin. XXXX is the pin name.

PIN/FUNCTION

No.	Pin Name	I/O	Function	Classification
1	EECS_N	O	EEPROM Chip Select Pin Connect to the C_N pin of the AK6514C (EEPROM). The output is Hi-Z when EESEL pin= "L".	EEPIF
2	EESO	I	EEPROM Serial Data Receive Pin (Internal pull-down) Connect to the SO pin of the AK6514C (EEPROM). Connect to DVSS or leave open when a EEPROM is not use.	
3	EECK	O	EEPROM Serial Data Output Clock Pin Connect to the SCK pin of the AK6514C (EEPROM). The output is Hi-Z when EESEL pin = "L".	
4	EESI	O	EEPROM Serial Data Output Pin Connect to the SI pin of the AK6514C. The output is Hi-Z when EESEL pin= "L".	
5	BVSS	-	Silicon Substrate Potential 0V Connect to AVSS.	Analog Power Supply
6	DVSS	-	Ground Pin for Digital Section 0.0V	Digital
7	DVDD	-	Power Supply Pin for Digital Section (3.3V typical)	Power Supply
8	RQ_N	I	Microprocessor Interface Write Request Pin (I2CSEL pin = "L") When initial reset state and Microcomputer interface are not in use, leave RQ_N pin= "H".	Microprocessor Interface.
	CAD1	I	I²C Bus Address Setting Pin 1 (I2CSEL pin = "H")	
9	RDY	O	Data Write Ready Output Pin for Microprocessor Interface	Microprocessor Interface
10	SO	O	Serial Data Output Pin for Microprocessor Interface When RQ_N pin = "H", SO pin= Hi-Z	
11	SI	I	Serial Data Input Pin for Microprocessor Interface (I2CSEL pin = "L") When SI is not used, tie the SI pin = "L".	
	CAD0	I	I²CSEL= "H" I²C Bus Address Pin 0	I ² C
12	DVSS	-	Ground Pin for Digital Section 0.0V	Digital
13	DVDD	-	Power Supply Pin for Digital Section (3.3V typical)	Power Supply
14	SCLK	I	Serial Data Clock Pin for Microprocessor Interface (I2CSEL pin = "L") When SCLK is not used, tie the SCLK pin = "H".	Microprocessor Interface
	SCL	I	I²C Bus Data Clock Pin (I2CSEL pin = "H")	
15	SDA	I/O	Test Pin (I2CSEL pin = "L") Leave open. SDA goes "L".	TEST
	SDA	I/O	I²C Bus Data Clock Pin (I2CSEL pin = "H")	I ² C
16	TESTO1	O	Test Output Pin Leave open. Normally TESTO1 goes "L".	TEST
17	STO	O	Status Output Pin	Status

No.	Pin Name	I/O	Function	Classification
18	DLINE_IN	I	HF Serial Data Input Pin (Internal pull-down) Compatible with MSB / LSB justified 24, 20 and 16 bits. Normally connected to Bluetooth line (receiving).	Digital Section Serial Input Data
19	DEXT_IN/ JX3	I	HF Serial Data Input Pin (Internal pull-down) Compatible with MSB / LSB justified 24, 20 and 16 bits. This pin changes to a conditional jump pin (JX3) by setting control register (JX3_E) to "1".	Digital Section Serial Input Data / Conditional Input
20	JX2	I	Conditional Jump Pin2 (Internal pull-down) A conditional jump pin (JX2) is available by setting control register (JX2_E) to "1".	Conditional Input
21	JX1	I	Conditional Jump Pin1 (Internal pull-down) A conditional jump pin (JX1) is available by setting control register (JX1_E) to "1".	
22	JX0	I	Conditional Jump Pin0 (Internal pull-down) A conditional jump pin (JX2) is available by setting control register (JX0_E) to "1".	
23	DVDD	-	Power Supply for Digital Section (3.3V typical)	Digital Power Supply
24	DVSS	-	Ground Pin for Digital Section 0V	
25	BITCLK_I	I	Serial Bit Clock Input Pin Normally connected to the Bluetooth Data Clock line (256kHz/512kHz).	System Clock
26	SYNC_I	I	SYNC Input Pin Normally connected to the Bluetooth Sync Clock line (8kHz).	
27	INIT_RESET_N	I	Reset Pin (for initialization) Use to initialize the AK7752. When changing CKM [3:0] and changing XTI or BITCLK_I input frequency, it is necessary to set this pin.	Reset
28	CK_RESET_N	I	Clock Reset Pin When changing CKM[3:0] and XTI or BITCLK_I input frequency without using INIT_RESET_N, it is necessary to set this pin. The control register CKRST has the same function.	
29	S_RESET_N	I	System Reset N Pin	
30	CKM[3]	I	Clock Mode Select Pin 3	Mode Select
31	CKM[2]	I	Clock Mode Select Pin 2	
32	CLKO1	O	Clock Output Pin 1 The output frequency is selected by a control register.	Clock Output

No.	Pin Name	I/O	Function	Classification
33	DEXT3_OUT	O	HF Serial Data Output Pin The data format is MSB justified.	TEST
34	EEST /RSTO_N	O	EES Output Pin / Internal Reset Monitor Pin Set by control resistor SEL_EEST. SEL_EEST bit=“0”: EEST pin SEL_EEST bit=“1”: RSTO_N Monitor internal reset process. RSTO_N pin =“L”: Reset mode, RSTO_N pin =“H”: Exit reset mode.	EEPIF/ Monitor
35	DEXT2_OUT	O	HF Serial Data Output Pin Compatible with MSB / LSB justified 24, 20 and 16 bits.	Digital Section Serial Input Data
36	DEXT1_OUT	O	HF Serial Data Input Pin Compatible with MSB / LSB justified 24, 20 and 16 bits.	
37	DLINE_OUT	O	HF Serial Data Output Pin Compatible with MSB / LSB justified 24, 20 and 16 bits. Normally connected to Bluetooth line (sending).	
38	BITCLK_O	O	Serial Bit Clock Output Pin Normally goes “L” by control register setting. Master Mode: Outputs 64fs or 32fs clock. Slave Mode: Outputs BITCLK_I clock.	System Clock
39	SYNC_O	O	SYNC Output Pin Normally goes “L” by control register setting. Master Mode: Outputs 64fs or 32fs clock. Slave Mode: Outputs SYNC_I clock.	
40	DVDD	-	Power Supply for Digital Section (3.3V typical)	Digital Power Supply
41	DVSS	-	Ground Pin for Digital Section 0V	
42	XTO	O	Crystal oscillator output pin When a crystal oscillator is used, connect it between XTI and XTO. When an external clock is used, leave this pin open.	System Clock
43	XTI	I	Crystal oscillator input pin Connect a crystal oscillator between this pin and the XTO pin, or input an external CMOS clock to the XTI pin.	
44	DVSS	-	Ground Pin for Digital Section 0V	Digital Power Supply
45	DVDD	-	Power Supply for Digital Section (3.3V typical)	
46	BVSS	-	Silicon Substrate Potential 0V Connect to AVSS.	Analog Power Supply
47	EESEL	I	Control Mode select pin (Internal pull-down) EESEL pin = “L” : Normal mode EESEL pin = “H”: In self-boot up mode using an AKM EEPROM, AK6514C	EEPIF
48	I2CSEL	I	I²C BUS Select Pin (Internal pull-down) I2CSEL pin = “L”: Normal serial interface I2CSEL pin = “H”: I2C Bus selected mode. SCL and SDA are active. I2CSEL should be connected to “L” (DVSS) or “H” (DVDD).	I ² C Select
49	TESTI2	I	TEST pin (Internal pull-down) Connect to DVSS.	TEST

No.	Pin Name	I/O	Function	Classification
50	CKM[1]	I	Clock Mode Select Pin 1	Mode Select
51	CKM[0]	I	Clock Mode Select Pin 0	
52	TEST1	I	TEST pin (Internal pull-down) Connect to DVSS.	TEST
53	LFLT	O	PLL RC component connect pin Connect a series resistor and capacitor pair to this pin.	Analog Output
54	AVSS	-	Analog ground Pin 0V (Silicon substrate potential)	Analog Power Supply
55	AVDD	-	Power Supply Pin for Analog Section (3.3V typical)	
56	ANE_IN	I	ADC Analog Input Pin (ANE_IN) Normally connected to the microphone amplifier.	Analog Input
57	ALINE_IN	I	ADC Analog Input Pin (ALINE_IN) Normally the receiving analog phone voice signal is input.	
58	AVDD	-	Analog Power Supply Pin (3.3V typical)	Analog Power Supply
59	VREFH	I	Analog Reference Voltage Input Pin Connect this pin to AVDD. Connect capacitors of 0.1 uF and 10 uF between this pin and AVSS.	Analog Input
60	VCOM	O	Analog Common Voltage Output pin Connect capacitors of 0.1 uF and 10 uF between this pin and AVSS. No external circuits should be connected to this pin.	Analog Output
61	VREFL	I	Analog Reference Voltage Input pin Connect this pin to AVSS.	Analog Input
62	AVSS	-	Analog ground Pin 0V (Silicon substrate potential)	Analog Power Supply
63	ALINE_OUT	O	DAC Analog Output Pin (ALINE_OUT) Normally the sending analog phone voice signal is output.	Analog Output
64	ANE_OUT	O	DAC Analog Output Pin (ANE_OUT) Normally connected to the speaker amplifier.	

Note 1. Do NOT leave digital input pins open except for pins that indicate “Internal pull down”, BITCLK_I and SYNC_I at master mode. (Internal pull down pins except TEST1 and TEST2 pins leave them open or connect them to DVSS. Connect TEST1 and TEST2 pins to DVSS).

Note 2. When analog input pins (ALINE_IN, ANE_IN) are not used, leave them open.

Note 3. Connect I2CSEL to “L” (DVSS) or “H” (DVDD).

Relationship between I2CSEL and SDA

uP I/F	I2CSEL	INIT_RESET_N	SDA
Normal Serial Interface	L	L	L
	L	H	L
I ² C Bus Mode	H	L	“Hi-Z” → pull-up
	H	H	function

ABSOLUTE MAXIMUM RATINGS

(AVSS, BVSS, DVSS=0V: All voltages are with respect to ground)

Parameter	Symbol	min	max	Units
Power Supply Voltage				
Analog (AVDD)	VA	-0.3	4.6	V
Digital (DVDD)	VD	-0.3	4.6	V
AVSS(BVSS) – DVSS (Note 4)	Δ GND		0.3	V
Input Current (except for power supply pin)	IIN	-	\pm 10	mA
Analog Input Voltage				
ALINE IN, ANE IN	VINA	-0.3	VA+0.3	V
Digital Input Voltage	VIND	-0.3	VD+0.3	V
Operating Ambient Temperature	Ta	-40	85	°C
Storage Temperature	Tstg	-65	150	°C

Note 4. AVSS, BVSS and DVSS must be connected to the same ground plane..

WARNING: Operation at or beyond these limits may result in permanent damage to the device.
Normal operation is not guaranteed at these extremes.

RECOMMENDED OPERATING CONDITIONS

(AVSS, BVSS, DVSS=0V: All voltages indicated are relative to the ground)

Parameter	Symbol	min	typ	max	Units
Power Supply Voltage					
AVDD	VA	3.0	3.3	3.6	V
DVDD	VD	3.0	3.3	3.6	V
Reference Voltage (VREF)					
VREFH (Note 5)	VRH		VA		V
VREFL (Note 6)	VRL		0.0		V

Note 5. VREFH is normally connected to AVDD.

Note 6. VREFL is normally connected to AVSS

Note: The analog input voltage and output voltage are proportional to the VREFH-VREFL voltages.
When using the AK6514C, the same voltage as used for the digital section of the AK7752 is recommended.

* AKEMD assumes no responsibility for the usage beyond the conditions in this datasheet.

ELECTRIC CHARACTERISTICS

(1) Analog Characteristics**1) fs=8kHz**

(Ta = 25°C; AVDD, DVDD = 3.3V; VREFH = AVDD, VREFL = AVSS;
 BITCLK = 64fs; Signal frequency 1kHz; Measurement frequency = 20Hz to 3.4 kHz; fs = 8kHz;
 CKM Mode 0 (CKM[3:0]=LLLL) Unless otherwise specified.)

	Parameter	min	typ	max	Units	
ADC Section	Resolution	24			Bits	
	Dynamic Characteristics					
	S/(N+D) (-1dBFS)	76	86		dB	
	Dynamic Range (Note 7)	81	89		dB	
	S/N	81	89		dB	
	Inter-Channel Isolation (f=1kHz) (Note 8.)	90	105		dB	
	DC accuracy					
	Channel Gain Mismatch		0.2	0.5	dB	
	Analog Input					
	Input Voltage (Note 9)	1.78	1.98	2.18	Vp-p	
	Input Impedance	40	60		kΩ	
DAC Section	Resolution	18			Bits	
	Dynamic Characteristics					
	S/(N+D) (0dB)	80	90		dB	
	Dynamic Range (Note 7)	87	95		dB	
	S/N	87	95		dB	
	Inter-Channel Isolation (f=1kHz) (Note 10)	85	100		dB	
	DC accuracy					
	Channel Gain Mismatch		0.2	0.5	dB	
	Analog Output					
	Output Voltage (Note 11)	1.85	2.00	2.15	Vp-p	
	Load Resistance	10			kΩ	
Load Capacitance			50	pF		

Note 7. S/(N+D) when -60dB signal is applied.

Note 8. Inter-channel isolation between ALINE_IN and ANE_IN at -1dB FS signal input.

Note 9. The full scale for analog input voltage is FS = (VREFH-VREFL) * 0.6.

Note 10. Between ANE_OUT and ALINE_OUT.

Note 11. Full scale output voltage when VREFH = AVDD, VREFL = AVSS.

2) fs=48kHz

(Ta = 25°C; AVDD, DVDD = 3.3V; VREFH = AVDD, VREFL = AVSS;
 BITCLK = 64fs; Signal frequency 1kHz; Measurement frequency = 20Hz to 3.4kHz; fs = 48kHz;
 CKM Mode 0 (CKM [3:0]=LLLL) Unless otherwise specified.)

	Parameter	min	typ	max	Units	
ADC Section	Resolution	24			Bits	
	Dynamic Characteristics					
	S/(N+D) (-1dBFS)	76	86		dB	
	Dynamic Range (A-weighted) (Note 12)	83	91		dB	
	S/N (A-weighted)	83	91		dB	
	Inter-Channel Isolation (f=1kHz) (Note 13)	90	110		dB	
	DC accuracy					
	Channel Gain Mismatch		0.2	0.5	dB	
	Analog Input					
	Input Voltage (Note 14)	1.80	2.00	2.20	Vp-p	
	Input Impedance	35	50		kΩ	
DAC Section	Resolution	18			Bits	
	Dynamic Characteristics					
	S/(N+D) (0 dB)	78	88		dB	
	Dynamic Range (A-weighted) (Note 12)	87	95		dB	
	S/N (A-weighted)	87	95		dB	
	Inter-Channel Isolation (f=1kHz) (Note 15)	85	100		dB	
	DC Accuracy					
	Channel Gain Mismatch		0.2	0.5	dB	
	Analog input					
	Output Voltage (Note 16)	1.85	2.00	2.15	Vp-p	
	Load Resistance	10			kΩ	
Load Capacitance			50	pF		

Note 12. S/(N+D) when -60dB signal is applied.

Note 13. Inter-channel isolation between ALINE_IN and ANE_IN at -1 dB FS signal input.

Note 14. The full scale for analog input voltage is FS=(VREFH-VREFL)×0.606.

Note 15. Between ANE_OUT and ALINE_OUT.

Note 16. Full scale output voltage when VREFH=AVDD, VREFL=AVSS.

(2) DC Characteristics

(Ta=-40°C ~ 85°C; AVDD, DVDD=3.0 ~ 3.6V)

Parameter	Symbol	min	typ	max	Units
High Level Input Voltage (Note 17)	V _{IH}	80%VDD			V
Low Level Input Voltage (Note 17)	V _{IL}			20%VDD	V
SCL, SDA High Level Input Voltage	V _{IH}	70%VDD			V
SCL, SDA Low Level Input Voltage	V _{IL}			30%VDD	V
High Level Output Voltage I _{out} =-100μA (Note 18)	V _{OH}	VDD-0.5			V
Low Level Output Voltage I _{out} =100μA	V _{OL}			0.5	V
SDA Low Level Output Voltage I _{out} =3mA	V _{OL}			0.4	V
Input Leak Current (Note 19)	I _{in}			±10	μA
Input Leak Current (pull-down pin) (Note 20)	I _{id}		22		μA
Input Leak Current (XTI pin)	I _{ix}		26		μA

Note 17. SCL and SDA pins are not included. (SI, SCLK pins are included)

Note 18. SDA pin is not included.

Note 19. Pull-down pins and XTI pin are not included.

Note 20. EESO, DLINE_IN, DEXT_IN / JX3, JX2, JX1, JX0, EESEL, I2CSEL, TESTI2 and TESTI1 (Typ150kΩ)

(3) Current Consumption

(Ta=25°C; AVDD, DVDD=3.0~3.6V (typ = 3.3V, max = 3.6V))

Parameter	min	typ	max	Units
Power Supply Current (Note 21)				
AVDD		10		mA
DVDD		90		mA
AVDD + DVDD		100	165	mA

Note 21. The current of DVDD changes depending on the system frequency and contents of the DSP program.

(4) Digital Filter Characteristics

1) ADC Section:

(Ta= 25°C; AVDD, DVDD=3.0 ~ 3.6V; fs = 8kHz; Note 22)

Parameter	Symbol	min	typ	max	Units
Passband (±0.1dB) (Note 23) (-1.0dB) (-3.0dB)	PB	0		3.15	kHz
			3.63		kHz
			3.83		kHz
Stopband	SB	4.66			kHz
Passband Ripple (Note 23)	PR			±0.1	dB
Stopband Attenuation (Note 24, Note 25)	SA	65			dB
Group Delay Distortion	GD			0	µs
Group Delay (Ts=1/fs)	GD		16.3		Ts

Note 22. HPF response is not included.

Note 23. The passband is from DC to 3.15kHz when fs = 8kHz.

Note 24. The stopband is from 4.66kHz to 507.34kHz when fs = 8kHz.

Note 25. When fs = 8 kHz, the analog modulator samples the analog input at 512kHz

2) DAC Section:

(Ta=25°C; AVDD, DVDD=3.0~3.6V; fs=8kHz)

Parameter	Symbol	min	typ	max	Units
Digital Filter					
Passband (±0.1dB) (Note 26) (-6.0dB)	PB	0		3.5	kHz
		-	4.0	-	kHz
Stopband (Note 26)	SB	4.57			kHz
Passband Ripple	PR			±0.01	dB
Stopband Attenuation	SA	59			dB
Group Delay (Ts=1/fs) (Note 27)	GD	-	15		Ts
Digital Filter + SCF					
Amplitude Characteristics 0~3.5kHz			±0.5		dB

Note 26. The pass band and stop band frequencies are proportional to “fs” (system sampling rate), and represents PB=0.4292fs (@-0.06dB) and SB=0.571fs, respectively.

Note 27. The digital filter’s delay is calculated as the time from setting 18 Bit data into the input register until an analog signal is output.

(5) Switching Characteristics**1) System Clock**

(Ta=-40°C~85°C; AVDD, DVDD=3.0~3.6V)

Parameter	Symbol	min	typ	max	Units
XTI CKM Mode 0-6					
a) with a Crystal Oscillator:					
Frequency (CKM Mode 0/2)	fXTI	-	11.2896 12.288	-	MHz
Frequency (CKM Mode 1/3)	fXTI	-	24.576	-	MHz
b) with an External Clock					
Duty Cycle		40	50	60	%
Frequency (CKM Mode 0/2)	fXTI	11.0		12.4	MHz
Frequency (CKM Mode 1/3)	fXTI	22		24.8	MHz
Clock Rise Time	tCR			6	ns
Clock Fall Time	tCF			6	ns
SYNC_I Frequency (Note 28)	Fs	7.35	8	48	kHz
Clock rise time	tLR			6	ns
Clock fall time	tLF			6	ns
BITCLK_I Frequency					
High Level Width	tBCLKH	120			ns
Low Level Width	tBCLKL	120			ns
Clock Rise Time	tBR			6	ns
Clock Fall Time	tBF			6	ns
a) CKM Mode 2/3 (Note 29)	fBCLK	32		64	fs
Duty Cycle		40	50	60	%
Frequency (CKM Mode 2/3)		0.23		3.2	MHz
b) CKM Mode 4 (Note 30)	fBCLK	-	32	-	fs
Duty Cycle		40	50	60	%
Frequency (CKM Mode 4)	fBCLK	230	256	258	kHz
c) CKM Mode 5/6 (Note 31)	fBCLK	-	64	-	fs
Duty Cycle		40	50	60	%
Frequency (CKM Mode 5)	fBCLK	460	512	516	kHz
Frequency (CKM Mode 6)	fBCLK	2.75	3.072	3.1	MHz

Note 28. SYNC_I frequency and sampling rate (fs) should be the same.

Note 29. When BITCLK_I is 32fs, I/O interface format has some limitation.

Note 30. When BITCLK_I is a source of master clock, it should be 32 times fs correctly.

Note 31. When BITCLK_I uses as a source of master clock, it should be 64 times fs correctly.

2) Reset

(Ta=-40°C~85°C; AVDD, DVDD=3.0~3.6V)

Parameter	Symbol	min	typ	max	Units
INIT RESET N (Note 32)	tRST	600			ns
CK RESET N	tRST	600			ns
S RESET N	tRST	600			ns

Note 32. The AK7752 can be powered up when INIT_RESET_N pin = "L". The power supply must be ON and the master clock must be input before the INIT_RESET_N pin transitions "H".

3) Audio interface

(Ta=-40°C~85°C; AVDD, DVDD=3.0~3.6V; CL=20pF)

Parameter	Symbol	min	typ	max	Units
Slave Mode (CKM Mode 2-4)					
Delay Time from BITCLK_I "↑" to SYNC_I (Note 33)	tBLRD	60			Ns
Delay Time from SYNC_I to BITCLK_I "↑" (Note 33)	tLRBD	60			Ns
Delay Time from SYNC_I, O to Serial Data Output	tLRD			80	ns
Delay Time from BITCLK_I, O to Serial Data Output	tBSOD			80	ns
Serial Data Output Latch Setup Time	tBSIDS	80			ns
Serial Data Input Latch Hold Time	tBSIDH	80			ns
Master Mode (CKM Mode 0-1)					
BITCLK_O Frequency (BIT32FS bit = "0")	fBCLK		64		fs
BITCLK_O Frequency (BIT32FS bit = "1")			32		fs
BITCLK_O Duty Factor			50		%
Delay Time from BITCLK_O "↑" to SYNC_O (Note 34)	tBLRD	60			ns
Delay Time from SYNC_O to BITCLK_O "↑" (Note 34)	tLRBD	60			ns
Delay Time from SYNC_O to Serial Data Output	tLRD			80	ns
Delay Time from BITCLK_O to Serial Data Output	tBSOD			80	ns
Serial Data Output Latch Setup Time	tBSIDS	80			Ns
Serial Data Input Latch Hold Time	tBSIDH	80			ns

Note 33. BITCLK_I "↑" must not occur at the same time as SYNC_I edge.

Note 34. BITCLK_O "↑" must not occur at the same time as SYNC_O edge.

(When control register SEL_BCK bit = "0". The edge reverses when SEL_BCK bit = "1".)

4) Microprocessor Interface

(Ta=-40°C~85°C; AVDD, DVDD=3.0~3.6V; CL=20pF)

Parameter	Symbol	min	typ	max	Units
Microprocessor Interface Signal					
RQ_N Fall Time	tWRF			30	ns
RQ_N Rise Time	tWRR			30	ns
SCLK Fall Time	tSF			30	ns
SCLK Rise Time	tSR			30	ns
SCLK Frequency	fSCLK			2.1	MHz
SCLK Low Level Width	tSCLKL	200			ns
SCLK High Level Width	tSCLKH	200			ns
Microprocessor to AK7752					
Time from S_RESET_N “↓” to RQ_N “↓”	tREW	500			ns
Time from RQ_N “↑” to S_RESET_N “↑”	tWRE	500			ns
RQ_N High Level Width	tWRQH	500			ns
Time from RQ_N “↓” to SCLK “↓”	tWSC	500			ns
Time from SCLK “↑” to RQ_N “↑”	tSCW	800			ns
SI Latch Setup Time	tSIS	200			ns
SI Latch Hold Time	tSIH	200			ns
Delay Time from SCLK “↓” to SO Output	tSOS			200	ns
Hold Time from SCLK “↑” to SO Output	tSOH	200			ns
Time from RQ_N “↓” to SO Hi-Z Release (Iout=±360μA)	tRQHR			600	ns
RQ_N “↑” to SO Hi-Z set (Iout=±360μA)	tRQHS			600	ns

5) I²C BUS Interface

(Ta=-40°C~85°C; AVDD, DVDD=3.0~3.6V)

Parameter	Symbol	min	typ	max	Units
I²C Timing					
SCL Clock Frequency	fSCL			400	KHz
Bus Free Time Between Transmissions	tBUF	1.3			μs
Start Condition Hold Time (prior to first Clock pulse)	tHD:STA	0.6			μs
Clock Low Time	tLOW	1.3			μs
Clock High Time	tHIGH	0.6			μs
Setup Time for Repeated Start Condition	tSU:STA	0.6			μs
SDA Hold Time from SCL Falling	tHD:DAT	0		0.9	μs
SDA Setup Time from SCL Rising	tSU:DAT	0.1			μs
Rise Time of Both SDA and SCL Lines	tR			0.3	μs
Fall Time of Both SDA and SCL Lines	tF			0.3	μs
Setup Time for Stop Condition	tSU:STO	0.6			μs
Pulse Width of Spike Noise Suppressed By Input Filter	tSP	0		50	ns
Capacitive Load on Bus	Cb			400	pF

 Note 35. I²C is a registered trademark of Philips Semiconductors.

6) EEPROM Interface

(Ta=-40°C ~ 85°C; AVDD, DVDD=3.0 ~ 3.6V; CL=20pF)

Parameter	Symbol	min	typ	max	Units
EEPROM→AK7752					
EESO Latch Setup Time (ESEL pin = "H")	tEESOS	160			ns
EESO Latch Hold Time (ESEL pin = "H")	tEESOH	160			ns
Time from ESEL "↑" to EECS_N, EECK, EESI Hi-Z release (Iout=±360μA)	tESLHR			600	ns
Time from ESEL "↓" to EECS_N, EECK, EESI Hi-Z set (Iout=±360μA)	tESLHS			600	ns

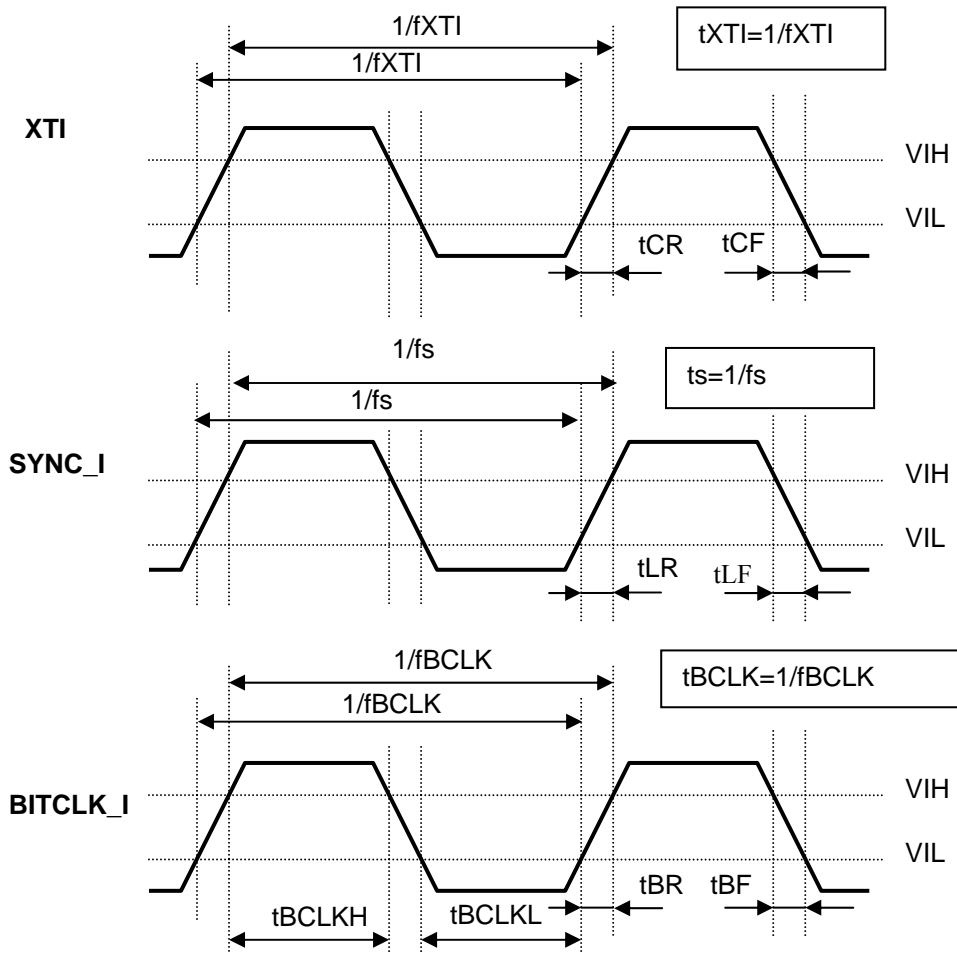
(6) Timing Diagram


Figure 2. System Clock

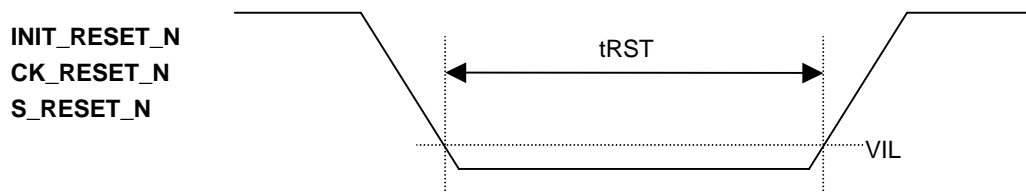


Figure 3. Reset

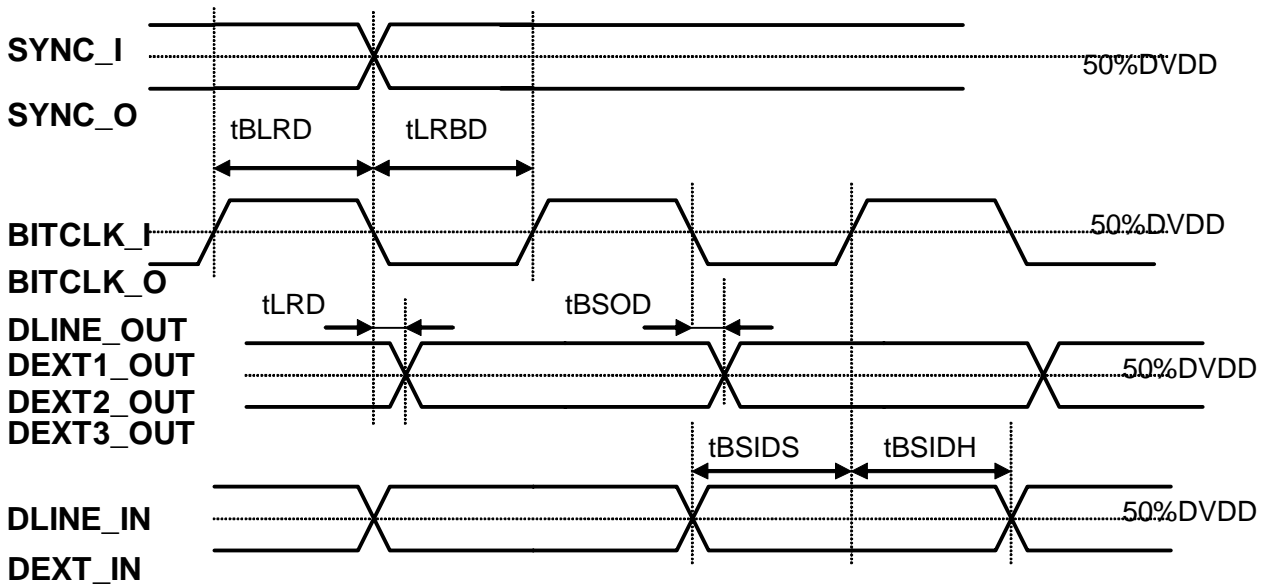


Figure 4. Audio Interface

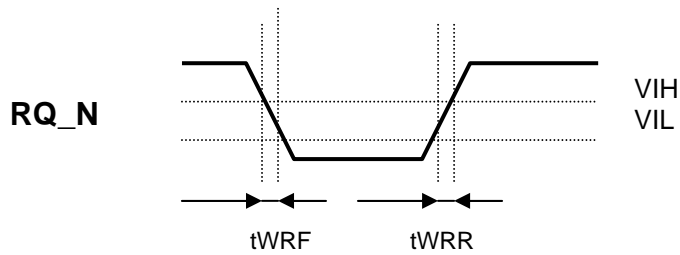


Figure 5. Microprocessor Interface Signal 1

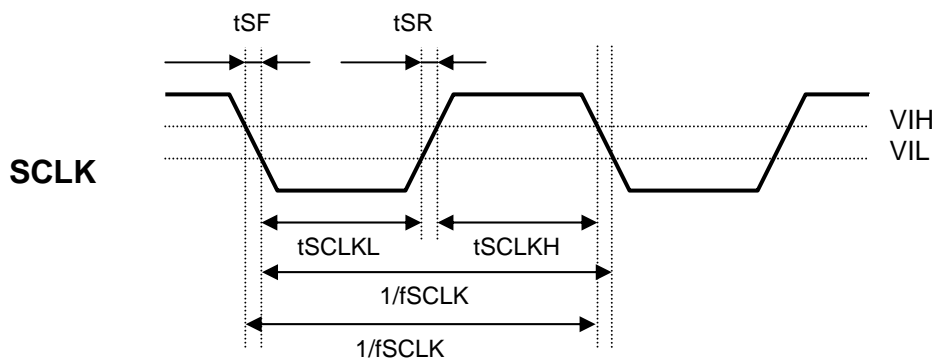


Figure 6. Microprocessor Interface Signal 2

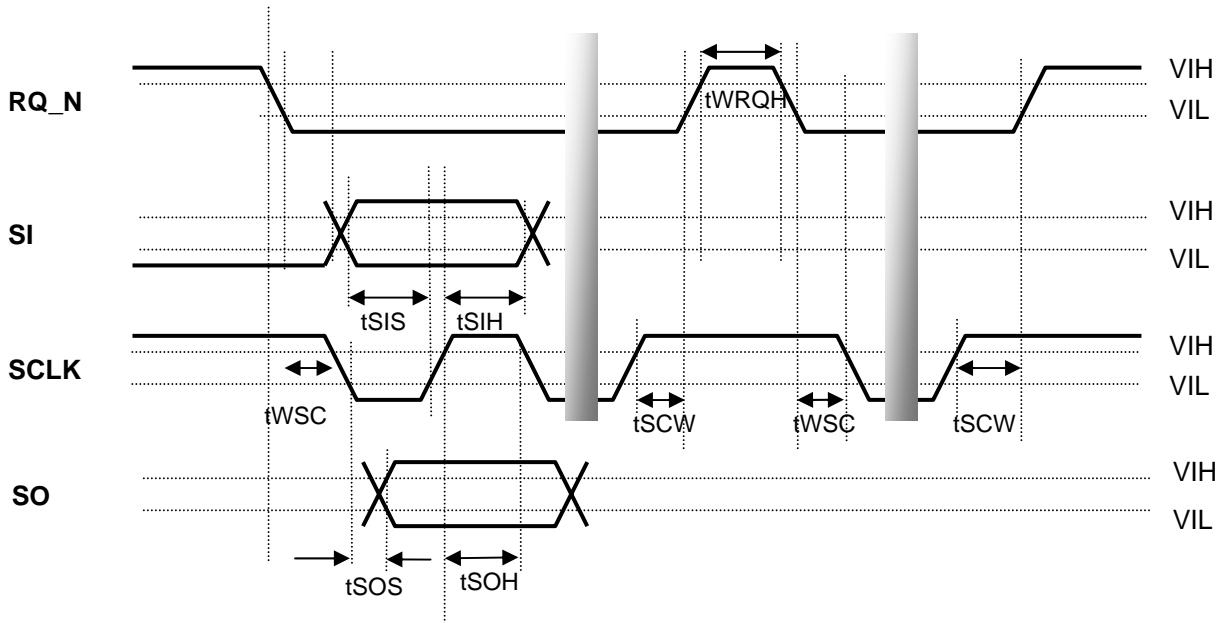


Figure 7. Microprocessor → AK7752

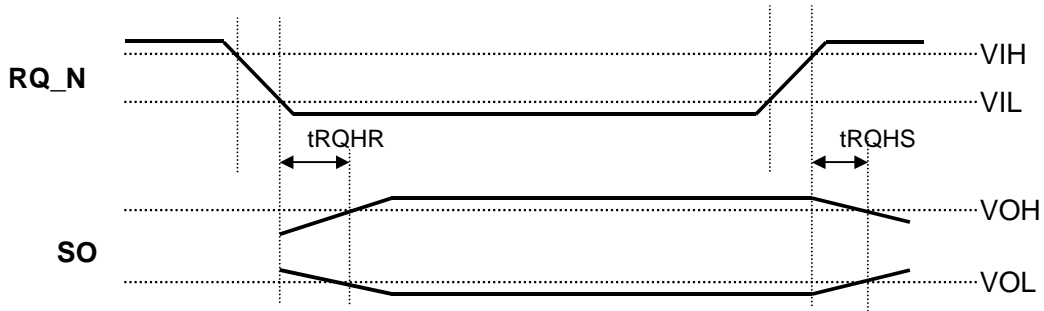


Figure 8. Microprocessor → AK7752

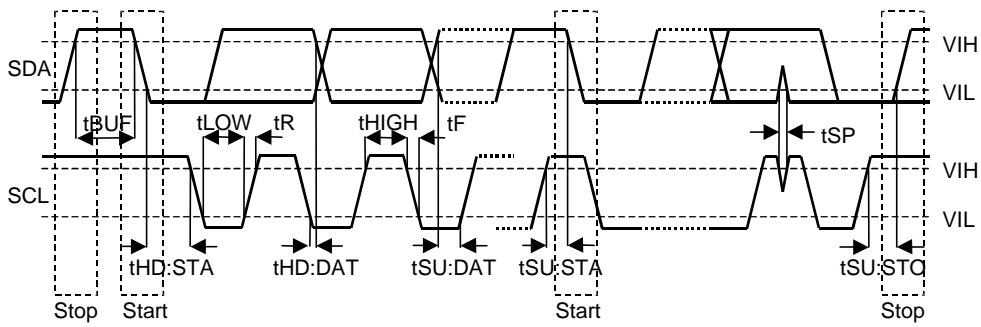


Figure 9. I²C Bus Interface

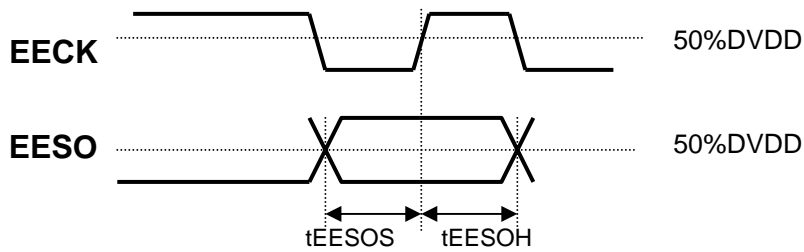


Figure 10. EEPROM Interface 1

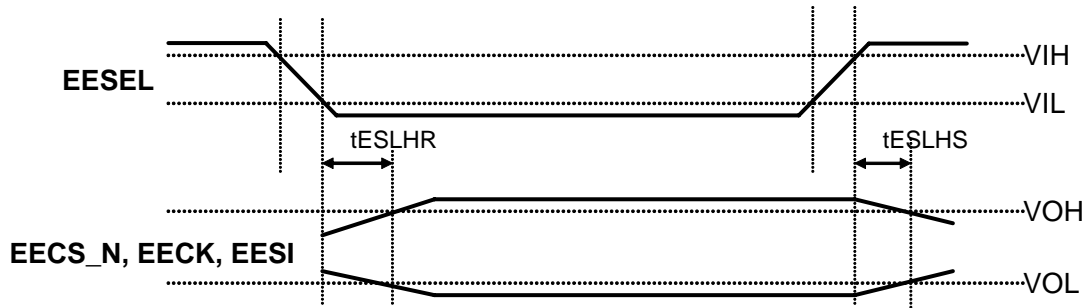
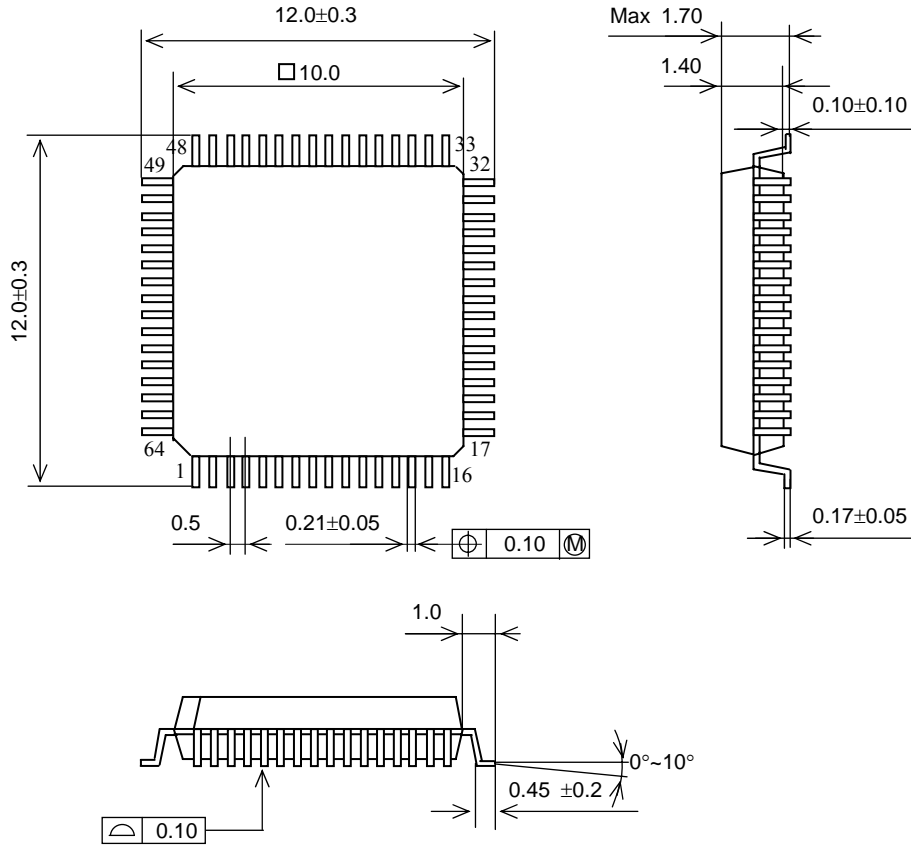


Figure 11. EEPROM Interface 2

PACKAGE

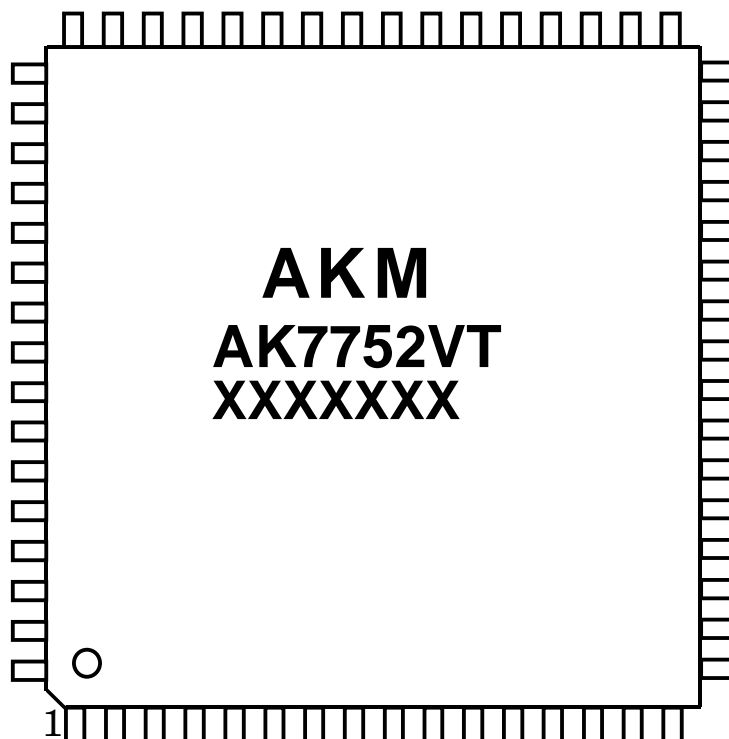
64pin LQFP (Unit: mm)



Material & Lead finish

Package:	Epoxy
Lead-frame:	Copper
Lead-finish:	Soldering plate (Pb free)

MARKING



- 1) Pin #1 indication
- 2) Date Code: XXXXXXXX (7 digits)
- 3) Marking Code: AK7752VT
- 4) Asahi Kasei Logo

IMPORTANT NOTICE

- These products and their specifications are subject to change without notice.
 When you consider any use or application of these products, please make inquiries the sales office of Asahi Kasei EMD Corporation (AKEMD) or authorized distributors as to current status of the products.
- AKEMD assumes no liability for infringement of any patent, intellectual property, or other rights in the application or use of any information contained herein.
- Any export of these products, or devices or systems containing them, may require an export license or other official approval under the law and regulations of the country of export pertaining to customs and tariffs, currency exchange, or strategic materials.
- AKEMD products are neither intended nor authorized for use as critical components^{Note1)} in any safety, life support, or other hazard related device or system^{Note2)}, and AKEMD assumes no responsibility for such use, except for the use approved with the express written consent by Representative Director of AKEMD. As used here:
 Note1) A critical component is one whose failure to function or perform may reasonably be expected to result, whether directly or indirectly, in the loss of the safety or effectiveness of the device or system containing it, and which must therefore meet very high standards of performance and reliability.
 Note2) A hazard related device or system is one designed or intended for life support or maintenance of safety or for applications in medicine, aerospace, nuclear energy, or other fields, in which its failure to function or perform may reasonably be expected to result in loss of life or in significant injury or damage to person or property.
- It is the responsibility of the buyer or distributor of AKEMD products, who distributes, disposes of, or otherwise places the product with a third party, to notify such third party in advance of the above content and conditions, and the buyer or distributor agrees to assume any and all responsibility and liability for and hold AKEMD harmless from any and all claims arising from the use of said product in the absence of such notification.

Thank you for your access to AKEMD product informations.
More detail product informations are available, please contact
our sales office or authorized distributors.