



AK5367A

96kHz 24-Bit $\Delta\Sigma$ ADC with 0V Bias Selector

GENERAL DESCRIPTION

AK5367A is a high-performance 24-bit, 96kHz sampling ADC for consumer audio and digital recording applications. The AK5367A uses an Enhanced Dual-Bit modulator architecture, this analog-to-digital converter has an impressive dynamic range of 102dB with high level integration. The AK5367A has a 4-channel stereo input selector, an input Programmable Gain Amplifier with resistance. All this integration with high-performance makes the AK5367A well suited for CD and DVD recording systems. The integrated charge pump circuit can generate the negative power supply and remove the output coupling capacitor.

FEATURES

1. 24bit Stereo ADC
 - 4:1 0V Bias Stereo input Selector
 - Digital HPF for offset cancellation ($f_c=1.0\text{Hz}@f_s=48\text{kHz}$)
 - Decimation LPF: $-0.2\text{dB}@20\text{kHz}$, $-3.0\text{dB}@23\text{kHz}$ ($f_s=48\text{kHz}$)
 - Soft Mute
 - Single-end Inputs
 - S/(N+D): 90dB
 - DR, S/N: 102dB
 - Audio I/F Format: 24bit MSB justified, I²S
2. Control Interface: I²C-Bus
3. Master Mode / Slave Mode
4. Master Clock:
 - 256fs/384fs (32kHz ~ 96kHz)
 - 512fs/768fs (32kHz ~ 48kHz)
5. Sampling Rate: 32kHz to 96kHz
6. Power Supply
 - Analog Supply: 4.5 ~ 5.5V
 - Digital Supply: 3.0 ~ 3.6V
7. Ta = $-20 \sim 85^\circ\text{C}$
8. Package: 30pin VSOP

■ Block Diagram

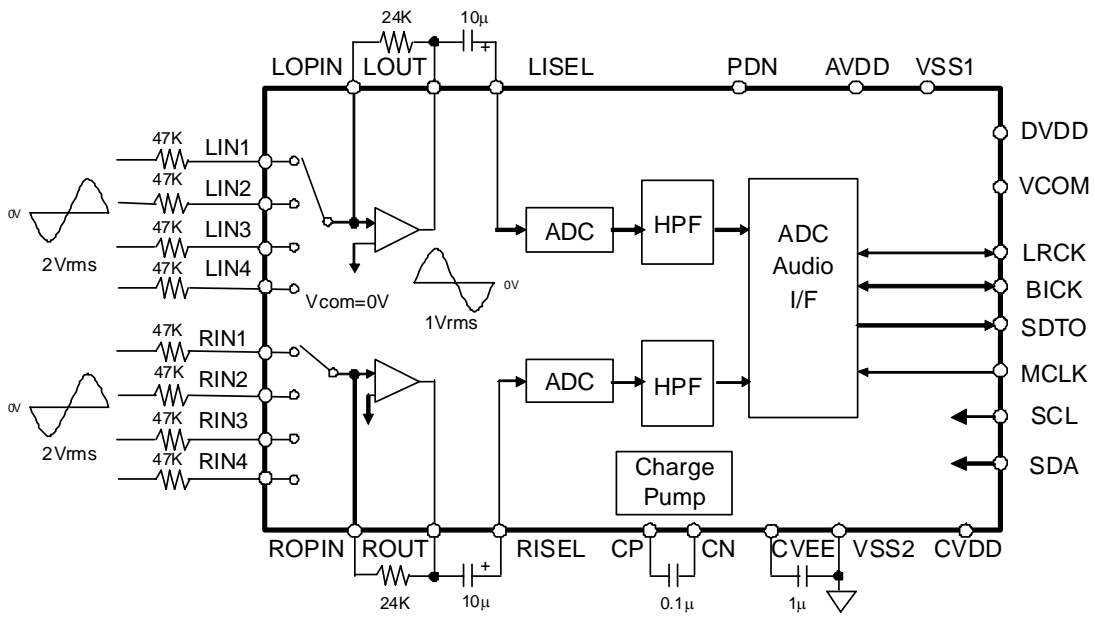

Figure 1. AK5367A Block Diagram

■ Ordering Guide

AK5367AEF
AKD5367A

-20 ~ +85°C 30pin VSOP (0.65mm pitch)
Evaluation Board for AK5367A

■ Pin Layout

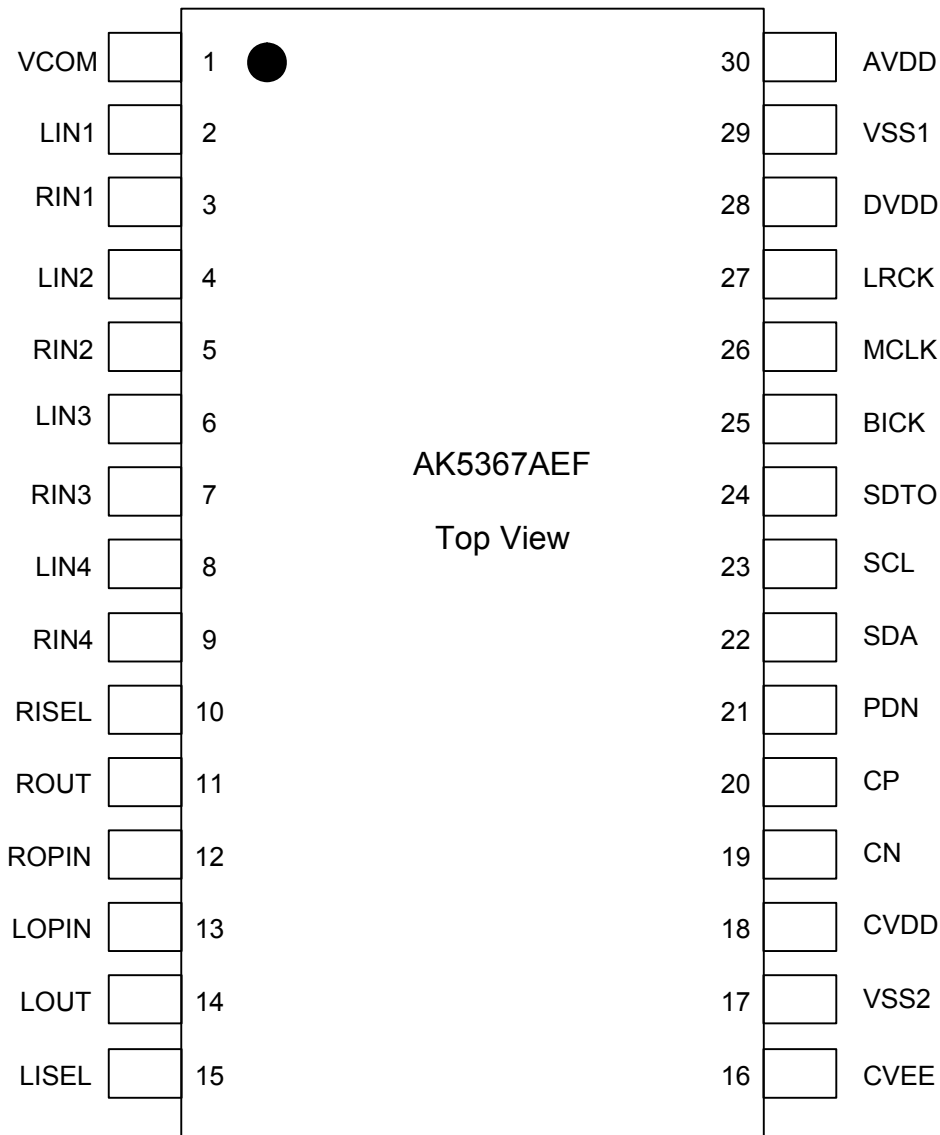

PIN/FUNCTION			
No.	Pin Name	I/O	Function
1	VCOM	O	Common Voltage Output Pin, AVDD/2 Bias voltage of ADC input.
2	LIN1	I	Lch Analog Input 1 Pin
3	RIN1	I	Rch Analog Input 1 Pin
4	LIN2	I	Lch Analog Input 2 Pin
5	RIN2	I	Rch Analog Input 2 Pin
6	LIN3	I	Lch Analog Input 3 Pin
7	RIN3	I	Rch Analog Input 3 Pin
8	LIN4	I	Lch Analog Input 4 Pin
9	RIN4	I	Rch Analog Input 4 Pin
10	RISEL	I	Rch Analog Input Pin
11	ROUT	O	Rch Feedback Resistor Output Pin
12	ROPIN	O	Rch Feedback Resistor Input Pin
13	LOPIN	O	Lch Feedback Resistor Input Pin
14	LOUT	O	Lch Feedback Resistor Output Pin
15	LISEL	I	Lch Analog Input Pin
16	CVEE	O	Negative Voltage Output Pin Connect to VSS2 with a 1.0 μ F capacitor which is low ESR (Equivalent Series Resistance) over all temperature range. When this capacitor has the polarity, the positive polarity pin must be connected to the VSS2 pin. Non polarity capacitors can also be used.
17	VSS2	-	Charge Pump Ground Pin, 0V Connect to CVEE with a 1.0 μ F capacitor which is low ESR (Equivalent Series Resistance) over all temperature range. When this capacitor has the polarity, the positive polarity pin must be connected to the VSS2 pin. Non polarity capacitors can also be used.
18	CVDD	-	Charge Pump Power Supply Pin, 3.0V~3.6V
19	CN	I	Negative Charge Pump Capacitor Terminal Pin Connect to CP with a 0.1 μ F capacitor which is low ESR (Equivalent Series Resistance) over all temperature range. When this capacitor has the polarity, the positive polarity pin must be connected to the CP pin. Non polarity capacitors can also be used.
20	CP	O	Positive Charge Pump Capacitor Terminal Pin Connect to CN with a 0.1 μ F capacitor which is low ESR (Equivalent Series Resistance) over all temperature range. When this capacitor has the polarity, the positive polarity pin must be connected to the CP pin. Non polarity capacitors can also be used.
21	PDN	I	Power Down Mode & Reset Pin “H”: Power up, “L”: Power down & Reset The AK5367A must be reset once upon power-up.
22	SDA	I/O	Control Data Input / Output Pin in I ² C Control
23	SCL	I	Control Data Clock Pin in I ² C Control
24	SDTO	O	Audio Serial Data Output Pin “L” Output at Power-down mode.
25	BICK	I/O	Audio Serial Data Clock Pin “L” Output in Master Mode at PWN bit= “0”.
26	MCLK	I	Master Clock Input Pin

No.	Pin Name	I/O	Function
27	LRCK	I/O	Channel Clock Pin “L” Output in Master Mode at PWN bit= “0”.
28	DVDD	-	Digital Power Supply Pin, 3.0~ 3.6V
29	VSS1	-	Analog Ground Pin
30	AVDD	-	Analog Power Supply Pin, 4.5 ~ 5.5V

Note: All input pins except analog input pins (RISEL, LISEL, LIN1-4, RIN1-4) must not be left floating.

■ Handling of Unused Pin

The unused input pins should be processed appropriately as below.

Classification	Pin Name	Setting
Analog	LIN1-4,RIN1-4,LISEL,RISEL LOPIN,LOUT,ROPIN,ROUT	These pins must be open.

ABSOLUTE MAXIMUM RATINGS

(VSS1=VSS2=0V; Note 1, Note 2)

Parameter		Symbol	min	max	Units
Power Supplies:	Analog	AVDD	-0.3	6.0	V
	Digital	DVDD	-0.3	6.0	V
	Charge Pump	CVDD	-0.3	4.0	V
Input Current, Any Pin Except Supplies		IIN	-	±10	mA
Analog Input Voltage(LISEL,RISEL,LIN1-4, RIN1-4 pins)		VINA	-0.3	AVDD+0.3	V
Digital Input Voltage (Note 3)		VIND	-0.3	DVDD+0.3	V
Ambient Temperature (Powered applied)		Ta	-20	85	°C
Storage Temperature		Tstg	-65	150	°C

Note 1. All voltages with respect to ground.

Note 2. VSS1 and VSS2 must be connected to the same analog ground plane.

Note 3. PDN, SCL, SDA, MCLK, BICK, LRCK pins

WARNING: Operation at or beyond these limits may result in permanent damage to the device.
Normal operation is not guaranteed at these extremes.

RECOMMENDED OPERATING CONDITIONS

(VSS1=VSS2=0V; Note 1)

Parameter		Symbol	min	typ	max	Units
Power Supplies (Note 4)	Analog	AVDD	4.5	5.0	5.5	V
	Digital	DVDD	3.0	3.3	3.6	V
	Charge Pump	CVDD	3.0	3.3	3.6	V
	DVDD-CVDD	ΔVDD	-0.3	0	+0.3	V

Note 4. The power up sequence between AVDD, DVDD and CVDD is not critical.

In slave mode, the AK5367A must be power up at the PDN pin = "L".

In master mode, the AK5367A must be power up at the PDN pin = "L", or when DVDD is powered up, MCLK clock must input and the AK5367A must be reset by the PDN pin="L". The internal register data is unknown until PDN pin="L". The power on/off sequence between AVDD, DVDD and CVDD is not critical, however when DVDD is powered off, all digital input pins must be left floating or held to VSS.

The power off is means that AVDD, CVDD and DVDD are floating or short to VSS.

WARNING: AKM assumes no responsibility for the usage beyond the conditions in this datasheet.

ANALOG CHARACTERISTICS

(Ta=25°C; AVDD=5.0V, DVDD=CVDD=3.3V; VSS1=VSS2=0V; fs=48kHz,96kHz; BICK=64fs;
Signal Frequency=1kHz; 24bit Data; Measurement frequency=20Hz ~ 20kHz at fs=48kHz, 40Hz ~ 40kHz at fs=96kHz;
unless otherwise specified)

Parameter	min	typ	max	Units	
Pre-Amp Characteristics:					
Feedback Resistance	10		50	kΩ	
S/(N+D) (Note 5)	-	100		dB	
S/N (A-weighted) (Note 5)	-	108		dB	
Load Resistance R_L (Note 6)	15			kΩ	
Load Capacitance C_L (Note 6)			20	pF	
ADC Analog Input Characteristics: (Note 7)					
Resolution			24	Bits	
Input Voltage (Note 8)	2.7	3.0	3.3	Vpp	
S/(N+D)	fs=48kHz BW=20kHz	-1dBFS	82	90	dB
		-60dBFS	-	39	dB
	fs=96kHz BW=40kHz	-1dBFS	-	90	dB
		-60dBFS	-	37	dB
DR (-60dBFS, A-weighted)	94	102		dB	
S/N (A-weighted)	94	102		dB	
Interchannel Isolation (fs=48kHz) (Note 9)	85	96		dB	
Interchannel Gain Mismatch		0.1	0.5	dB	
Gain Drift		100	-	ppm/°C	
Power Supply Rejection (Note 10)	-	50		dB	
Power Supplies					
Power Supply Current					
Normal Operation (PDN pin = "H")					
AVDD		15.5	23	mA	
CVDD		2.5	4	mA	
DVDD (fs=48kHz)		2	3	mA	
DVDD (fs=96kHz)		4	6	mA	
Power down mode (PDN pin = "L") (Note 11)					
AVDD+DVDD		10	100	μA	

Note 5. This value is measured at LOUT and ROUT pins using $R_i=47k\Omega$, $R_f=24k\Omega$ when the input signal voltage is $2V_{rms}$.

Note 6. This value of R_L and C_L are load resistance and capacitance that the LOUT and ROUT pins can drive. R_L does not include the feedback resistor (R_f) and the input impedance of the LISEL/RISEL pins. The value of C_L does not include the internal impedance of the AK5367A.

Note 7. This value is measured via the following path. Pre-Amp → ADC. ($R_i=47k\Omega$, $R_f=24k\Omega$)

Note 8. Input voltage to LISEL and RISEL pins is proportional to AVDD voltage. $V_{in} = 0.6 \times AVDD (V_{pp})$

Note 9. 93dB(typ.) at fs=96kHz.

Note 10. PSR is applied to AVDD and DVDD with 1kHz, 50mVpp Sine wave.

Note 11. All digital input pins are held DVDD or VSS2.

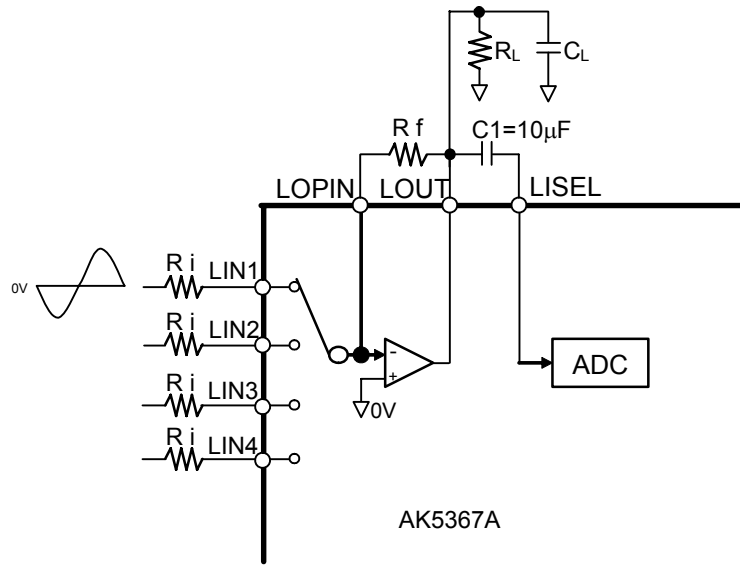

Figure 2. Pre-Amp Circuit

FILTER CHARACTERISTICS (fs=48kHz)

(Ta=-20 ~ 85°C; AVDD=4.5 ~ 5.5V; DVDD=CVDD=3.0 ~ 3.6V)

Parameter	Symbol	min	typ	max	Units
ADC Digital Filter (Decimation LPF):					
Passband (Note 12)	±0.1dB	PB	0	18.9	kHz
	-0.2dB		-	20.0	kHz
	-3.0dB		-	23.0	kHz
Stopband	SB	28			kHz
Passband Ripple	PR			±0.04	dB
Stopband Attenuation	SA	68			dB
Group Delay Distortion	ΔGD		0		μs
Group Delay (Note 13)	GD		20		1/fs
ADC Digital Filter (HPF):					
Frequency Response (Note 12)	-3dB	FR		1.0	Hz
	-0.1dB			6.5	Hz

FILTER CHARACTERISTICS (fs=96kHz)

(Ta=-20 ~ 85°C; AVDD=4.5 ~ 5.5V; DVDD=CVDD=3.0 ~ 3.6V)

Parameter	Symbol	min	typ	max	Units
ADC Digital Filter (Decimation LPF):					
Passband (Note 12)	±0.1dB	PB	0	37.8	kHz
	-0.2dB		-	40.0	kHz
	-3.0dB		-	46.0	kHz
Stopband	SB	56			kHz
Passband Ripple	PR			±0.04	dB
Stopband Attenuation	SA	68			dB
Group Delay Distortion	ΔGD		0		μs
Group Delay (Note 13)	GD		20		1/fs
ADC Digital Filter (HPF):					
Frequency Response (Note 12)	-3dB	FR		2.0	Hz
	-0.1dB			13.0	Hz

Note 12. The passband and stopband frequencies scale with fs. For example, PB= 18.9kHz@±0.1dB is 0.39375 x fs, (fs=48kHz).

Note 13. The calculated delay time induced by digital filtering. This time is from the input of an analog signal to the setting of 24bit data both channels to the ADC output register for ADC.

DC CHARACTERISTICS

(Ta=-20°C ~ 85°C; AVDD=4.5 ~ 5.5V; DVDD=CVDD=3.0 ~ 3.6V)

Parameter	Symbol	min	typ	max	Units
High-Level Input Voltage	VIH	70% DVDD	-	-	V
Low-Level Input Voltage	VIL	-	-	30% DVDD	V
High-Level Output Voltage (Iout=-1mA)	VOH	DVDD-0.5	-	-	V
Low-Level Output Voltage (Except SDA pin: Iout=1mA)	VOL	-	-	0.5	V
(SDA pin: Iout=3mA)	VOL	-	-	0.4	V
Input Leakage Current	Iin	-	-	±10	μA

SWITCHING CHARACTERISTICS

(Ta=-20°C ~ 85°C; AVDD=4.5 ~ 5.5V; DVDD=CVDD=3.0 ~ 3.6V; CL=20pF)

Parameter	Symbol	min	typ	max	Units
Master Clock Timing					
512fs, 256fs Frequency	fCLK	8.192		24.576	MHz
Pulse Width Low	tCLKL	16			ns
Pulse Width High	tCLKH	16			ns
768fs, 384fs Frequency	fCLK	12.288		36.864	MHz
Pulse Width Low	tCLKL	10.5			ns
Pulse Width High	tCLKH	10.5			ns
LRCK Frequency					
	fs	32		96	kHz
Duty Cycle		45		55	%
			50		%
Audio Interface Timing					
Slave mode					
BICK Period	tSCK	160			ns
BICK Pulse Width Low	tSCKL	65			ns
Pulse Width High	tSCKH	65			ns
LRCK Edge to BICK “↑” (Note 14)	tLRSH	30			ns
BICK “↑” to LRCK Edge (Note 14)	tSHLR	30			ns
LRCK to SDTO (MSB) (Except I ² S mode)	tLRS			35	ns
BICK “↓” to SDTO	tSSD			35	ns
Master mode					
BICK Frequency	fSCK		64fs		Hz
BICK Duty	dSCK		50		%
BICK “↓” to LRCK	tMSLR	-20		20	ns
BICK “↓” to SDTO	tSSD	-20		35	ns
Control Interface Timing (I²C Bus mode):					
SCL Clock Frequency	fSCL	-		400	kHz
Bus Free Time Between Transmissions	tBUF	1.3		-	μs
Start Condition Hold Time (prior to first clock pulse)	tHD:STA	0.6		-	μs
Clock Low Time	tLOW	1.3		-	μs
Clock High Time	tHIGH	0.6		-	μs
Setup Time for Repeated Start Condition	tSU:STA	0.6		-	μs
SDA Hold Time from SCL Falling (Note 15)	tHD:DAT	0		-	μs
SDA Setup Time from SCL Rising	tSU:DAT	0.1		-	μs
Rise Time of Both SDA and SCL Lines	tR	-		0.3	μs
Fall Time of Both SDA and SCL Lines	tF	-		0.3	μs
Setup Time for Stop Condition	tSU:STO	0.6		-	μs
Pulse Width of Spike Noise Suppressed by Input Filter	tSP	0		50	ns
Capacitive load on bus	Cb	-		400	pF

Note 14. BICK rising edge must not occur at the same time as LRCK edge.

Note 15. Data must be held long enough to bridge the 300ns-transition time of SCL.

Parameter	Symbol	min	typ	max	Units
Reset Timing					
PDN Pulse Width (Note 16)	tPD	150			ns
PDN “↑” to SDTO valid at Slave Mode (Note 17)	tPDV		4388		1/fs
PDN “↑” to SDTO valid at Master Mode (Note 17)	tPDV		4385		1/fs

Note 16. The AK5367A can be reset by bringing the PDN pin = “L”.

Note 17. This cycle is the number of LRCK rising edges from the PDN pin = “H”.

■ Timing Diagram

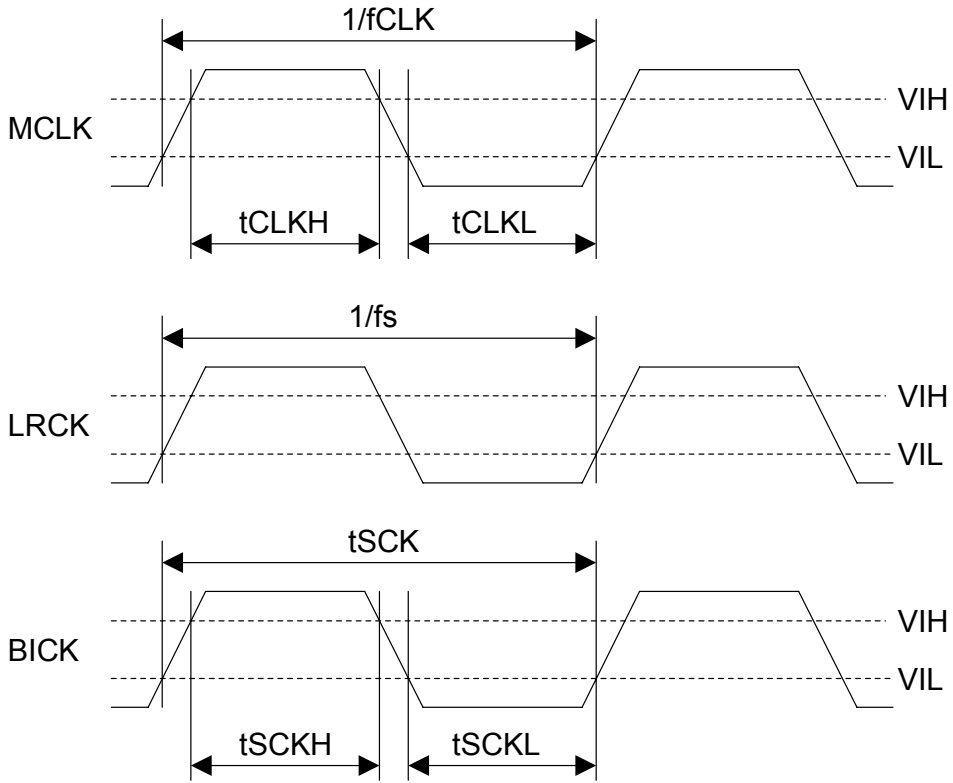

Figure 3. Clock Timing

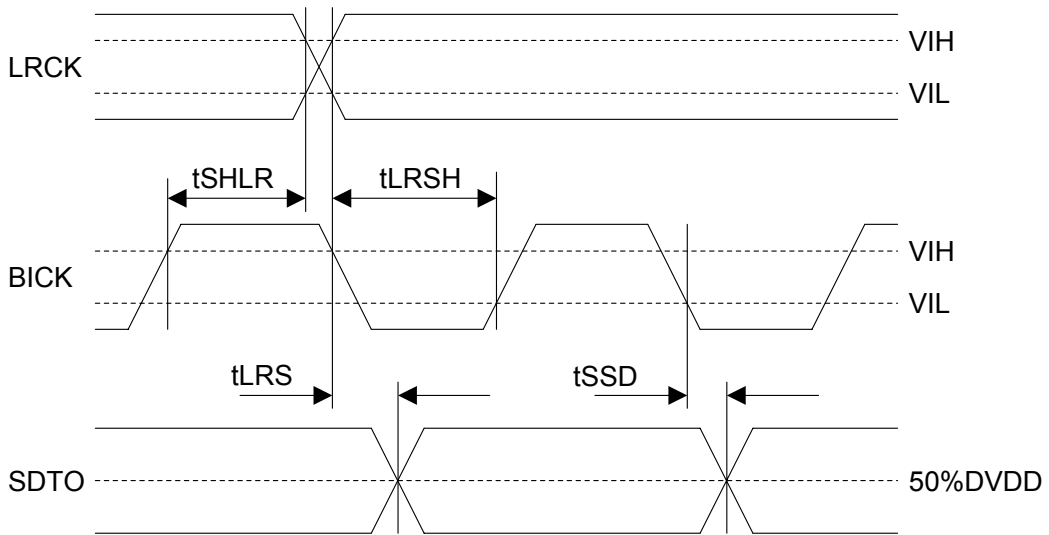

Figure 4. Audio Interface Timing (Slave mode)

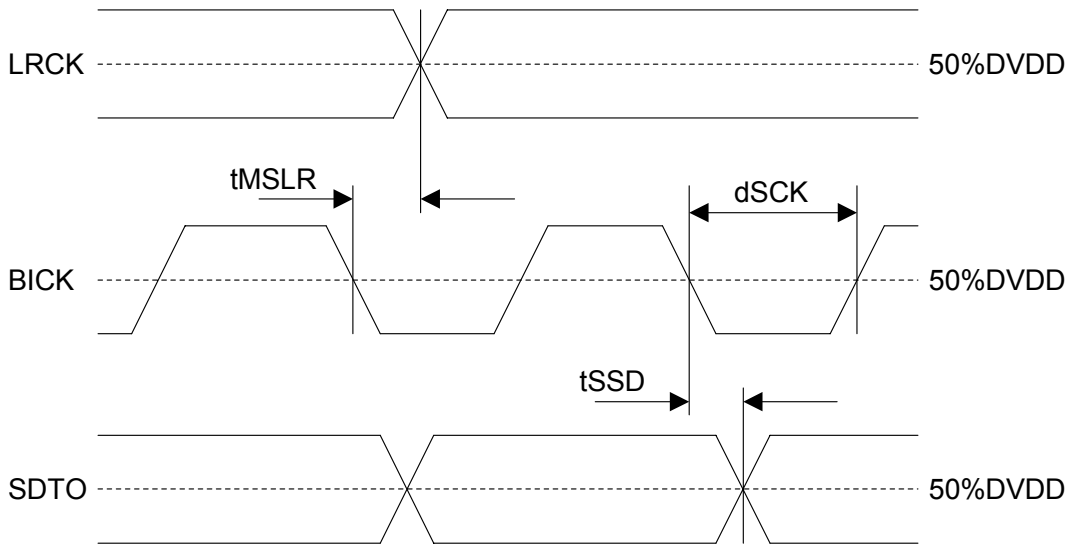

Figure 5. Audio Interface Timing (Master mode)

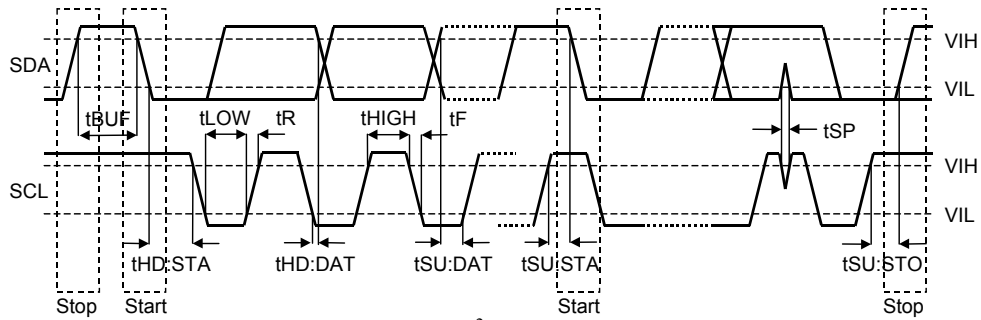

Figure 6. I²C Bus mode Timing

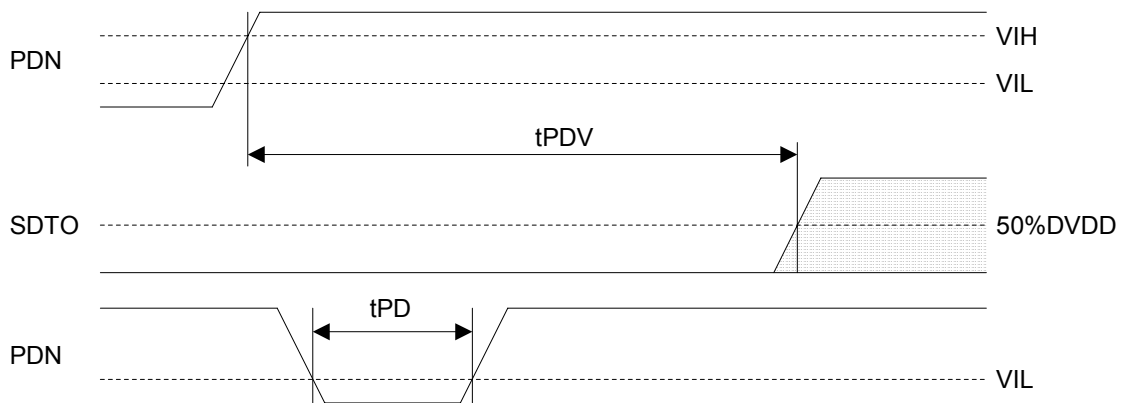

Figure 7. Power Down & Reset Timing

OPERATION OVERVIEW

■ System Clock

MCLK, BICK and LRCK clocks are required. The LRCK clock input must be synchronized with MCLK, however the phase is not critical. [Table 1](#) shows the relationship of typical sampling frequency and the system clock frequency. The MCLK, BICK and master/slave mode setting are selected by CKS2-0 bits([Table 2](#)).

In slave mode, all external clocks (MCLK, BICK and LRCK) must be present unless the PDN pin = "L". If these clocks are not provided, the AK5367A may draw excess current due to its use of internal dynamically refreshed logic. If the external clocks are not present, place the AK5367A in power-down mode (PDN pin = "L"). In master mode, the master clock (MCLK) must be provided unless the PDN pin = "L". It is not necessary to reset by bringing the PDN pin "L" when clocks and fs are changed. They should be changed after soft mute (SMUTE bit = "1") to avoid switching noise.

fs	MCLK			
	256fs	384fs	512fs	768fs
32kHz	8.192MHz	12.288MHz	16.384MHz	24.576MHz
44.1kHz	11.2896MHz	16.9344MHz	22.5792MHz	33.8688MHz
48kHz	12.288MHz	18.432MHz	24.576MHz	36.864MHz
96kHz	24.576MHz	36.864MHz	N/A	N/A

Table 1. System Clock Example (N/A: Not available)

Mode	CKS2	CKS1	CKS0	Master/Slave	MCLK	BICK
0	0	0	0	Slave	256/384fs (32k≤fs≤96k) 512/768fs (32k≤fs≤48k)	≥ 48fs or 32fs (Note 18)
1	0	0	1		Reserved	
2	0	1	0	Master	256fs (32k≤fs≤96k)	64fs
3	0	1	1	Master	512fs (32k≤fs≤48k)	64fs
4	1	0	0		Reserved	
5	1	0	1		Reserved	
6	1	1	0	Master	384fs (32k≤fs≤96k)	64fs
7	1	1	1	Master	768fs (32k≤fs≤48k)	64fs

(default)

Note 18. The SDTO output is 16bit when BICK=32fs input.

Table 2. Operation Mode Select

■ Audio Interface Format

Two kinds of data formats can be chosen with the DIF bit (Table 3). In both modes, the serial data is in MSB first, 2’s compliment format. The SDTO is clocked out on the falling edge of BICK. The audio interface supports both master and slave modes. In master mode, BICK and LRCK are output with the BICK frequency fixed to 64fs and the LRCK frequency fixed to 1fs.

Mode	DIF bit	SDTO	LRCK	BICK(Slave)	BICK(Master)	Figure
0	0	24bit, MSB justified	H/L	≥ 48fs or 32fs	64fs	Figure 8 (default)
1	1	24bit, I ² S Compatible	L/H	≥ 48fs or 32fs	64fs	Figure 9

Table 3. Audio Interface Format

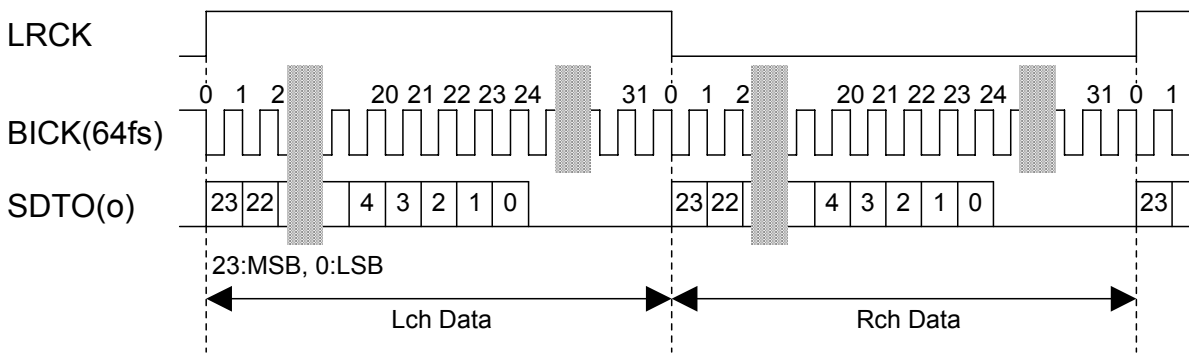

Figure 8. Mode 0 Timing

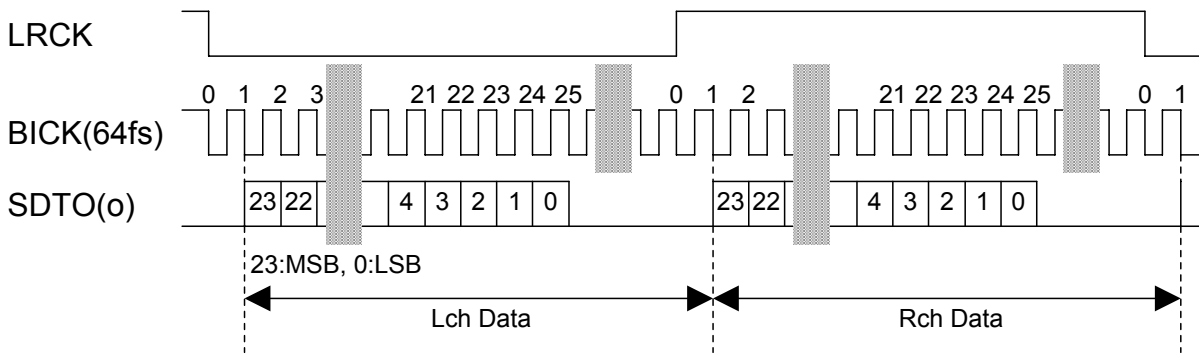

Figure 9. Mode 1 Timing

■ Master Mode and Slave Mode

The AK5367A becomes slave mode when it is in the power-down mode (PDN pin = “L”) or exiting power-down. After exiting the power-down mode, master mode should be set by CKS2-0 bits.

In master mode, LRCK and BICK pins are floating until CKS2-0 bits fixed. Therefore BICK and LRCK pins must be connected with 100 kΩ pull-up or pull-down resistance.

■ Digital High Pass Filter

The ADC has a digital high pass filter for DC offset cancellation. The cut-off frequency of the HPF is 1.0Hz (@fs=48kHz) and scales with sampling rate (fs).

■ Power-down

The AK5367A is placed in the power-down mode by bringing the PDN pin = "L" and the digital filter is also reset at the same time. This reset must always be executed after power-up. At the power-down mode, the VCOM voltage is VSS1. After exiting the power-down mode, the Charge pump circuit is powered up, then Pre-Amp circuit is automatically powered up and an analog initialization cycle starts (Figure 10). Therefore, the output data SDTO becomes available after 4388 x LRCK cycles at slave mode, and 4385 x LRCK cycles in master mode. In the initialization, the both channel of ADC output is "0" of 2's complement. After the initialization, the ADC output is settled equal to analog input signal. (the setting time is long as group delay)

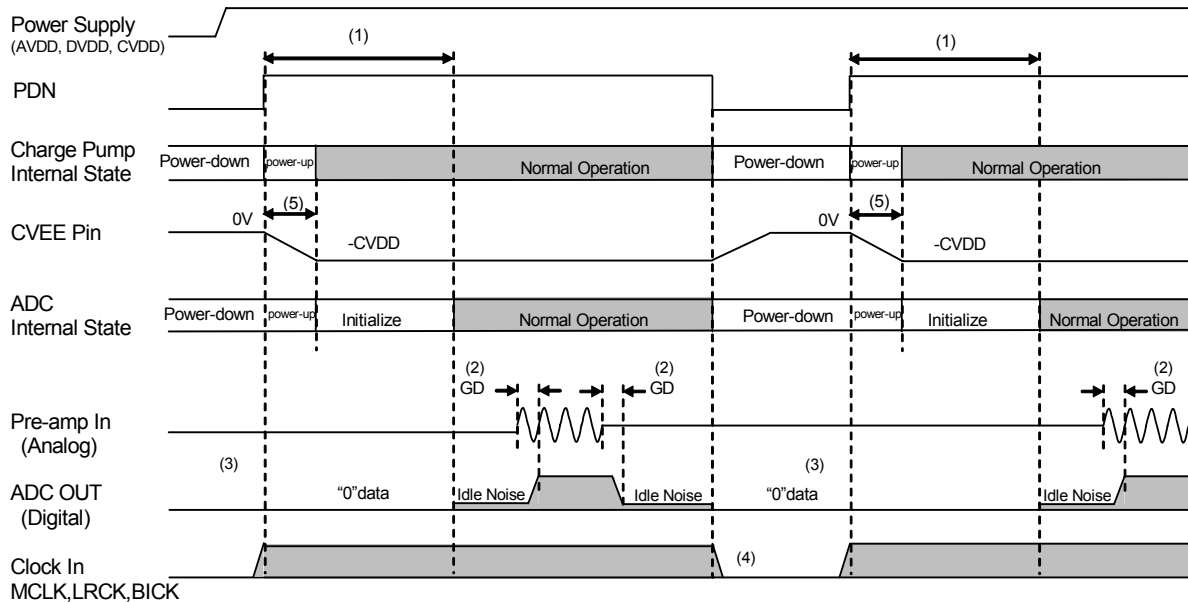

Notes:

- (1) 4388/fs at slave mode, 4385/fs at master mode.
- (2) Analog output corresponding to digital input has group delay (GD).
- (3) ADC output is "0" data at the power-down mode.
- (4) Place the AK5367A in power-down mode if MCLK, BICK and LRCK are not present.
- (5) Power-up time of Charge Pump Circuit. 260/fs (slave mode), 257/fs (master mode).

Figure 10. Power-down/up sequence example

■ System Reset

The AK5367A must be reset once by bringing the PDN pin “L” after power-up. At the slave mode, the internal timing starts clocking by the rising edge (falling edge at Mode 1) of LRCK after exiting from reset and power down state by MCLK. The AK5367A is in power-down states until the LRCK is input. At master mode, bringing the PDN pin “H” and exiting from reset and power down state by MCLK input.

■ Soft Mute Operation

Soft mute operation is performed in the digital domain of the ADC output. When SMUTE bit goes “1”, the ADC output data is attenuated to $-\infty$ within 1024 LRCK cycles. When the SMUTE bit returned “0”, the mute is cancelled and the output attenuation gradually changes to 0dB within 1024 LRCK cycles. If the soft mute is cancelled before mute state after starting of the operation, the attenuation is discontinued and returned to 0dB. The soft mute is effective for changing the signal source without stopping the signal transmission.

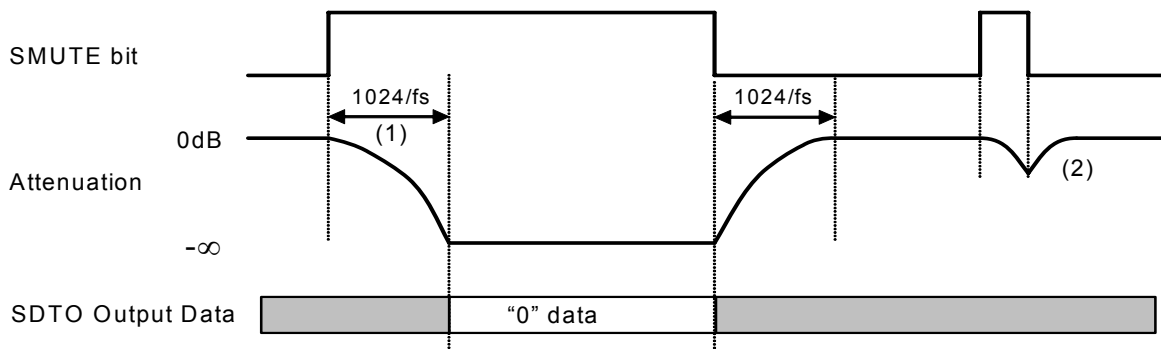

Figure 11. Soft Mute Function

Notes:

- (1) The output signal is attenuated by $-\infty$ within 1024 LRCK cycles ($1024/f_s$).
- (2) If the soft mute is cancelled before the mute, the attenuation is discontinued and returned to 0dB by the same cycle.

■ Input Selector

The AK5367A includes 4ch stereo input selectors. The input selector is 4 to 1 selector and set by SEL2-0 bits (Table 4).

SEL2 bit	SEL1 bit	SEL0 bit	Input Selector
0	0	0	LIN1 / RIN1
0	0	1	LIN2 / RIN2
0	1	0	LIN3 / RIN3
0	1	1	LIN4 / RIN4
1	0	0	All off (Note) (default)

Table 4. Input Selector

Note: The LOUT, ROUT pin are 0V.

[Input selector switching sequence]

The input selector should be changed after soft mute to avoid the switching noise of the input selector (Figure 12).

1. Enable soft mute before changing channel.
2. Change channel.
3. Disable soft mute.

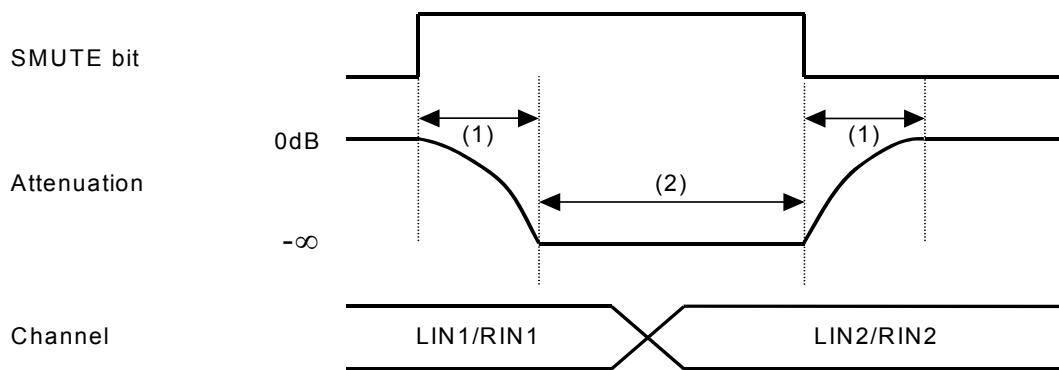

Figure 12. Input channel switching sequence example

Note:

- (1) The output signal is attenuated by $-\infty$ within 1024 LRCK cycles (1024/fs).
- (2) When changing channels, the input channel should be changed during (2). The period of (2) should be around 200ms because there is some DC difference between the channels.

■ Pre-Amp and Input Attenuator

The input ATTs are constructed by adding the input resistor (R_i) for LIN1-4/RIN1-4 pins and the feedback resistor (R_f) between LOPIN/ROPIN pin and LOU/ROU pin (Figure 13). The input voltage range of the LISEL/RISEL pin is typically $0.6 \times AVDD$ (V_{pp}). If the input voltage of the input selector exceeds typ. $0.6 \times AVDD$, the input voltage of the LISEL/RISEL pins must be attenuated to $0.6 \times AVDD$ by the input ATTs. Table 5 shows the example of R_i and R_f .

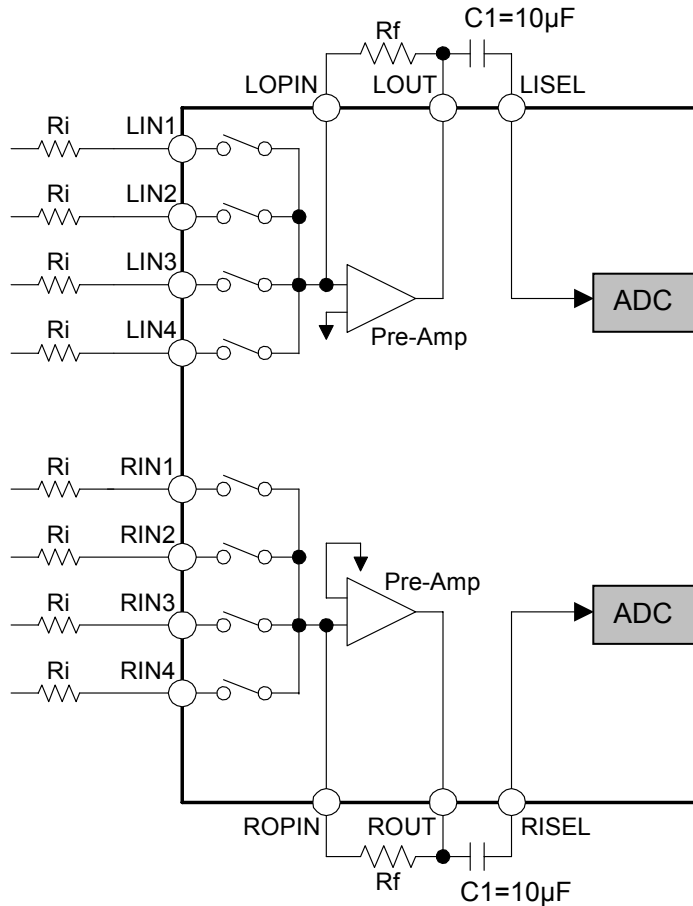

Figure 13. Pre-Amp and Input ATT

- Example for input range

Input Range	R_i [k Ω]	R_f [k Ω]	ATT Gain [dB]	LISEL/RISEL pin
4Vrms	47	12	-11.86	1.02Vrms
2Vrms	47	24	-5.84	1.02Vrms
1Vrms	47	47	0	1Vrms

Table 5. Input ATT example

Note: The value of R_i is over 10k Ω .

■ Charge Pump Circuit

The internal charge pump circuit generates negative voltage(CVEE) from CVDD voltage. The generated voltage is used for Pre-Amp.

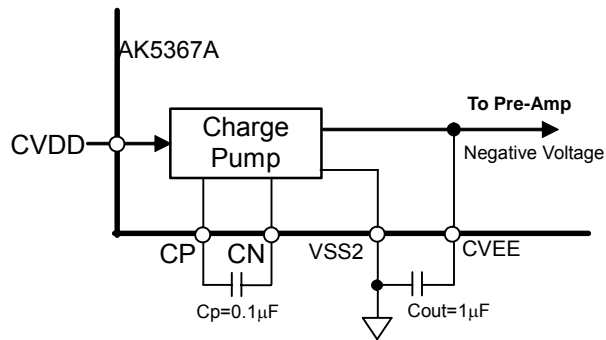

Figure 14. Charge Pump Circuit

■ Serial Control Interface

The AK5367A supports the first-mode I²C-bus system (max: 400kHz).
 The pull-up resistance of SDA,SCL pins should be connected below the voltage of DVDD+0.3V.

1. WRITE Operations

Figure 15 shows the data transfer sequence for the I²C-bus mode. All commands are preceded by START condition. A HIGH to LOW transition on the SDA line while SCL is HIGH indicates START condition (Figure 21). After the START condition, a slave address is sent. This address is 7 bits long followed by the eighth bit that is a data direction bit (R/W). The most significant 7 bits of the slave address are fixed as “0110001”. If the slave address matches that of the AK5367A, the AK5367A generates an acknowledge and the operation is executed. The master must generate the acknowledge-related clock pulse and release the SDA line (HIGH) during the acknowledge clock pulse (Figure 22). A R/W bit value of “1” indicates that the read operation is to be executed. “0” indicates that the write operation is to be executed.

The second byte consists of the control register address of the AK5367A. The format is MSB first, and those most significant 6-bits are fixed to zeros (Figure 17). The data after the second byte contains control data. The format is MSB first, 8bits (Figure 18). The AK5367A generates an acknowledge after each byte is received. A data transfer is always terminated by a STOP condition generated by the master. A LOW to HIGH transition on the SDA line while SCL is HIGH defines a STOP condition (Figure 21).

The AK5367A can perform more than one byte write operation per sequence. The master can transmit more than one byte instead of terminating the write cycle after the first data byte is transferred. After receiving each data packet the internal 2-bit address counter is incremented by one, and the next data is automatically taken into the next address. If the address exceeds 02H prior to generating the stop condition, the address counter will “roll over” to 00H and the previous data will be overwritten.

The data on the SDA line must remain stable during the HIGH period of the clock. The HIGH or LOW state of the data line can only change when the clock signal on the SCL line is LOW (Figure 23) except for the START and STOP conditions.

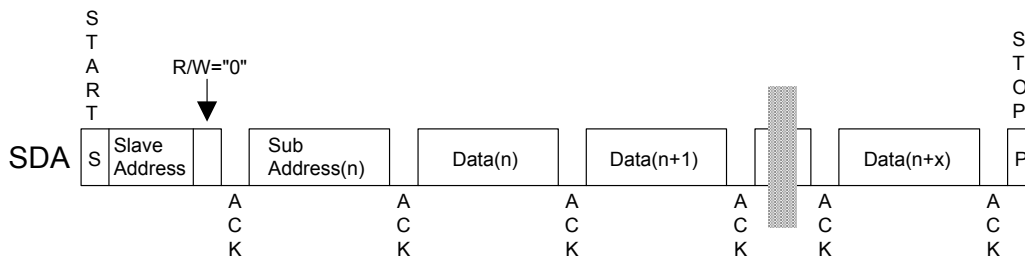

Figure 15. Data Transfer Sequence at the I²C-Bus Mode

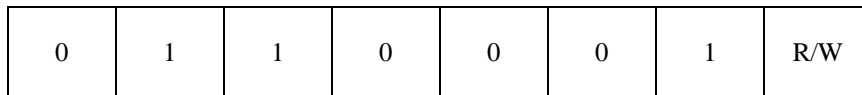

Figure 16. The First Byte

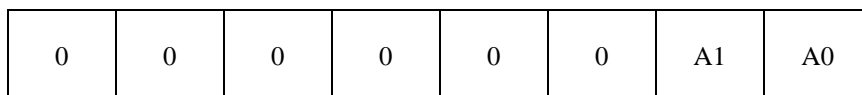

Figure 17. The Second Byte

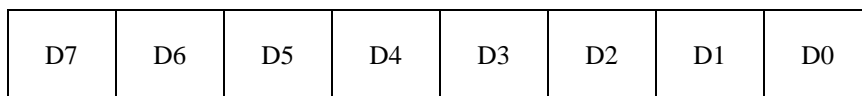

Figure 18. Byte Structure after the second byte

2. READ Operations

Set the R/W bit = "1" for the READ operation of the AK5367A. The master can read the next address's data by generating an acknowledge instead of terminating the write cycle after the receipt of the first data word. After receiving each data packet the internal 2-bit address counter is incremented by one, and the next data is automatically taken into the next address. If the address exceeds 02H prior to generating a stop condition, the address counter will "roll over" to 00H and the previous data will be overwritten.

The AK5367A supports two basic read operations: CURRENT ADDRESS READ and RANDOM ADDRESS READ.

2-1. CURRENT ADDRESS READ

The AK5367A contains an internal address counter that maintains the address of the last word accessed, incremented by one. Therefore, if the last access (either a read or write) were to address "n", the next CURRENT READ operation would access data from the address "n+1". After receipt of the slave address with R/W bit set to "1", the AK5367A generates an acknowledge, transmits 1-byte of data to the address set by the internal address counter and increments the internal address counter by 1. If the master does not generate an acknowledge but generates a stop condition, the AK5367A ceases transmission.

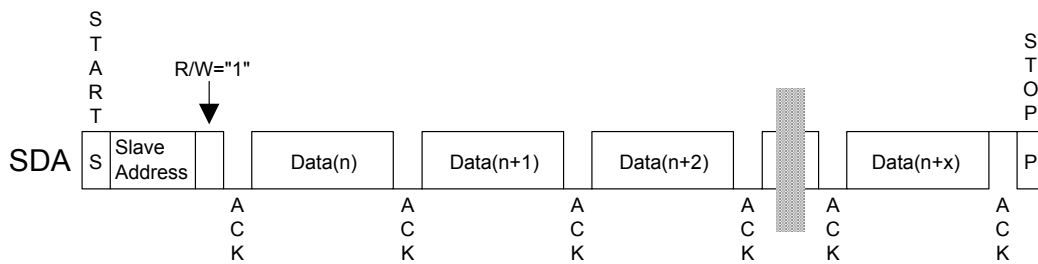

Figure 19. CURRENT ADDRESS READ

2-2. RANDOM ADDRESS READ

The random read operation allows the master to access any memory location at random. Prior to issuing the slave address with the R/W bit "1", the master must first perform a "dummy" write operation. The master issues start request, a slave address (R/W bit = "0") and then the register address to read. After the register address is acknowledged, the master immediately reissues start request and the slave address with the R/W bit "1". The AK5367A then generates an acknowledge, 1 byte of data and increments the internal address counter by 1. If the master does not generate an acknowledge but generates stop condition, the AK5367A ceases transmission.

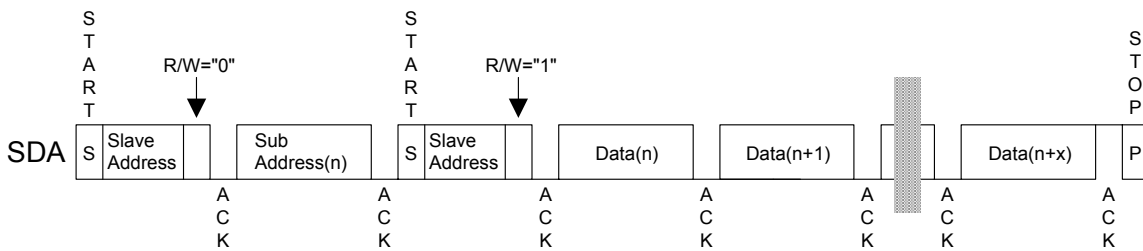

Figure 20. RANDOM ADDRESS READ

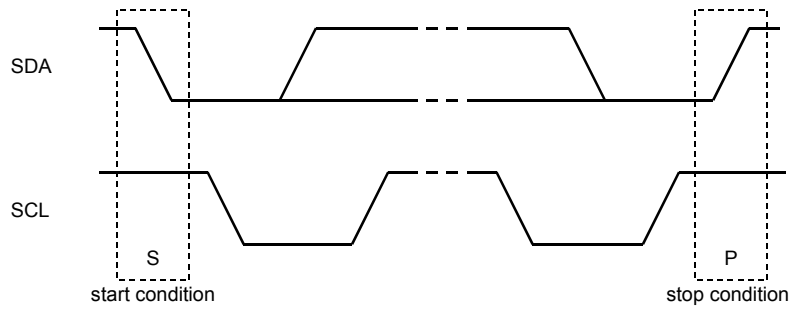

Figure 21. START and STOP Conditions

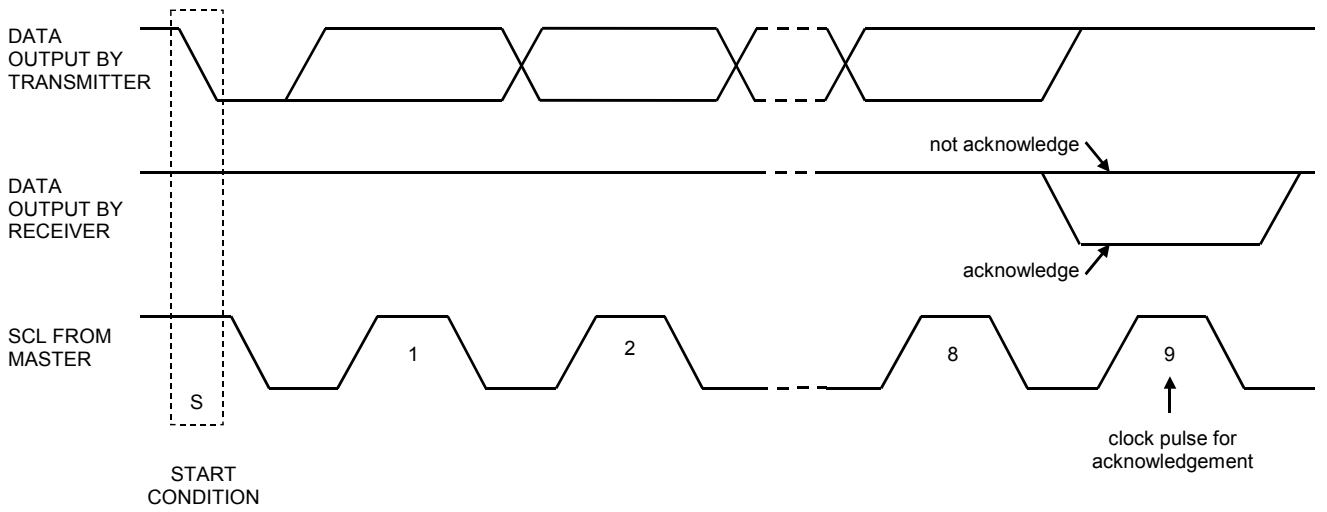

Figure 22. Acknowledge on the I²C-Bus

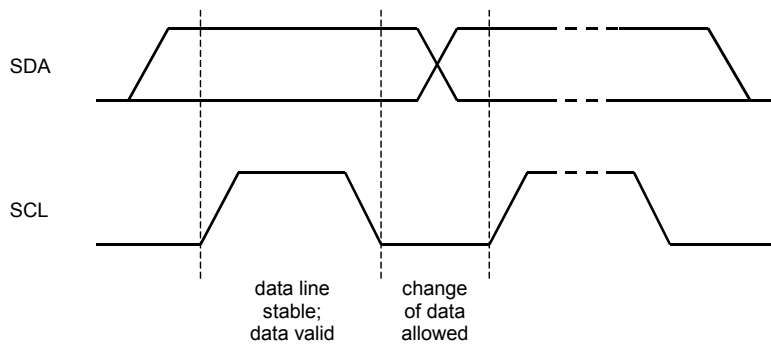

Figure 23. Bit Transfer on the I²C-Bus

■ Register Map

Addr	Register Name	D7	D6	D5	D4	D3	D2	D1	D0
00H	Power Down Control	0	0	0	0	0	0	0	PWN
01H	Input Selector Control	0	0	0	0	0	SEL2	SEL1	SEL0
02H	Clock & Format Control	0	0	0	DIF	CKS2	CKS1	CKS0	SMUTE

PDN pin = “L” resets the registers to their default values.

Note: Unused bits must contain a “0” value.

Only write to address 00H to 02H.

■ Register Definitions

Addr	Register Name	D7	D6	D5	D4	D3	D2	D1	D0
00H	Power Down Control	0	0	0	0	0	0	0	PWN
	R/W	RD	RD	RD	RD	RD	RD	RD	R/W
	Default	0	0	0	0	0	0	0	1

PWN: Power down control

0: Power down. All registers are not initialized.

1: Normal Operation (default)

“0” powers down all sections and then ADC do not operate. The contents of all register are not initialized and enabled to write to the registers.

Addr	Register Name	D7	D6	D5	D4	D3	D2	D1	D0
01H	Input Selector Control	0	0	0	0	0	SEL2	SEL1	SEL0
	R/W	RD	RD	RD	RD	RD	RD	R/W	R/W
	Default	0	0	0	0	0	1	0	0

SEL2-0: Input selector ([Table 4](#))

Initial values are “100”.

Addr	Register Name	D7	D6	D5	D4	D3	D2	D1	D0
02H	Clock & Format Control	0	0	0	DIF	CKS2	CKS1	CKS0	SMUTE
	R/W	RD	RD	RD	R/W	R/W	R/W	R/W	R/W
	Default	0	0	0	0	0	0	0	0

SMUTE: Soft Mute control

0: Normal Operation (default)

1: SDTO outputs soft-muted.

CKS2-0: Operation mode select ([Table 2](#))

Initial values are “000”.

DIF: Audio interface format ([Table 3](#))

Initial values are “0” (24bit, MSB justified).

SYSTEM DESIGN

Figure 24 shows the system connection diagram. The evaluation board (AKD5367A) demonstrates application circuits, the optimum layout, power supply arrangements and measurement results.

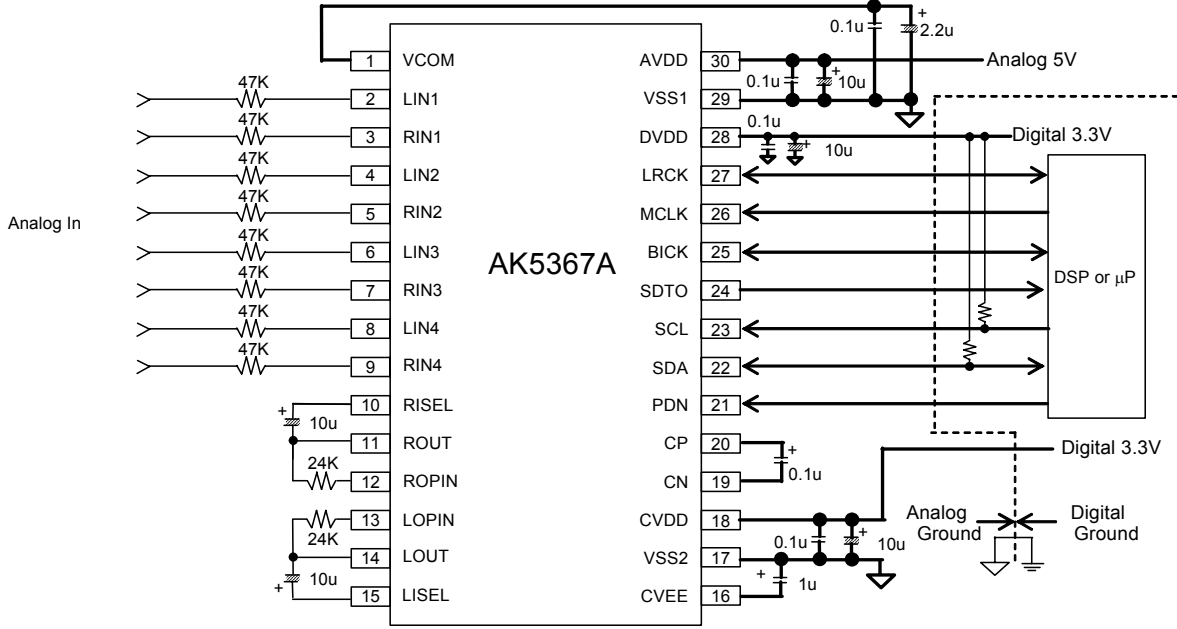

Figure 24. Typical Connection Diagram

1. Grounding and Power Supply Decoupling

The AK5367A requires careful attention to power supply and grounding arrangements. AVDD, DVDD and CVDD are usually supplied from the analog supply in the system. Alternatively if AVDD, DVDD and CVDD are supplied separately, the power up sequence is not critical. **VSS1 and VSS2 of the AK5367A must be connected to analog ground plane.** System analog ground and digital ground must be connected together near to where the supplies are brought onto the printed circuit board. Decoupling capacitors must be as near to the AK5367A as possible, with the small value ceramic capacitor being the closest.

2. Voltage Reference Inputs

The differential voltage between AVDD and VSS1 sets the analog input range. VCOM is a signal common of this chip. An electrolytic capacitor 2.2 μ F parallel with a 0.1 μ F ceramic capacitor attached to the VCOM pin eliminates the effects of high frequency noise. No load current may be drawn from the VCOM pin. All signals, especially clocks, should be kept away from the VCOM pins in order to avoid unwanted coupling into the AK5367A.

3. Analog Inputs

An analog input of AK5367A is single-ended input to Pre-Amp through the external resistor. For input signal range, adjust feedback resistor so that Pre-Amp output may become the input range (typ. 0.6 x AVDD Vpp) of ADC (LISEL,RISEL pin). Between the Pre-Amp output (LOUT, ROUT pin) and the ADC input (LISEL,RISEL pin) is AC coupled with capacitor. When the impedance of LISEL/RISEL pins is "R" and the capacitor of between the Pre-Amp output and the ADC input is "C", the cut-off frequency is $f_c = 1/(2\pi RC)$. The ADC output data format is 2's compliment. The internal HPF removes the DC offset. The AK5367A samples the analog inputs at 64fs. The digital filter rejects noise above the stop band except for multiples of 64fs. The AK5367A includes an anti-aliasing filter (RC filter) to attenuate a noise around 64fs.

4. Attention to the PCB Wiring

LIN1-4 and RIN1-4 pins are the summing nodes of the Pre-Amp. Attention should be given to avoid coupling with other signals on those nodes. This can be accomplished by making the wire length of the input resistors as short as possible. The same theory also applies to the LOPIN/ROPIN pins and feedback resistors; keep the wire length to a minimum. Unused input pins among LIN1-4 and RIN1-4 pins should be left open. When external devices are connected to LOUT and ROUT pin, the input impedance is min. 15k Ω .

4. I²C bus Connection

SCL and SDA pins should be connected to DVDD through the resistor based on I²C standard. As there is a protection between each pin and DVDD, the pulled up voltage must be DVDD or lower (Figure 25).

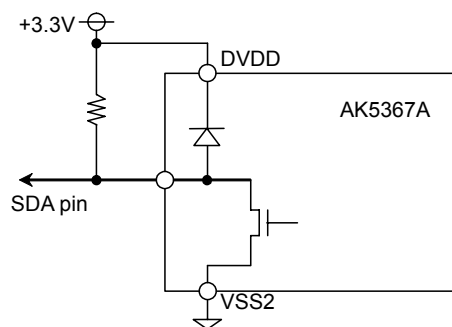
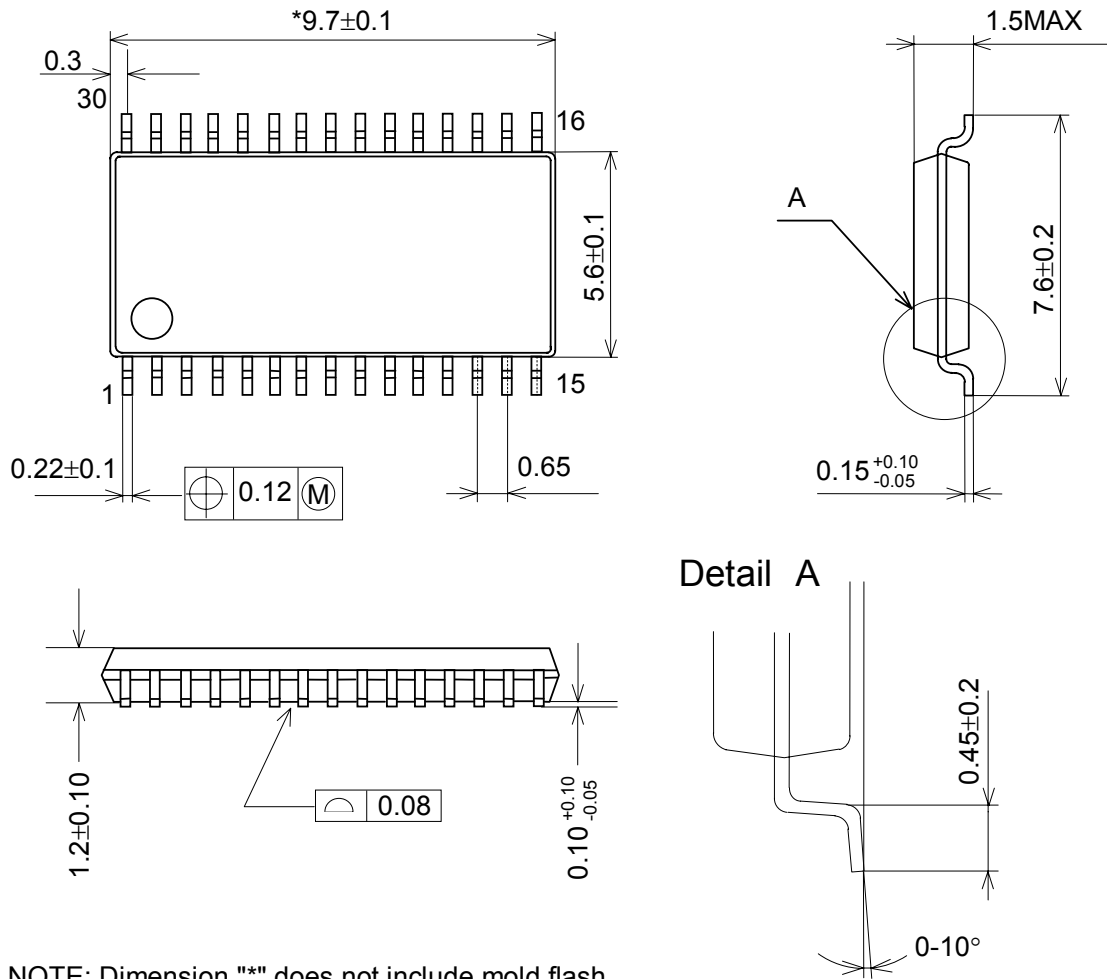

Figure 25. SDA pin output

PACKAGE

30pin VSOP (Unit: mm)



NOTE: Dimension "*" does not include mold flash.

■ Material & Lead finish

Package molding compound:	Epoxy
Lead frame material:	Cu
Lead frame surface treatment:	Solder (Pb free) plate

MARKING

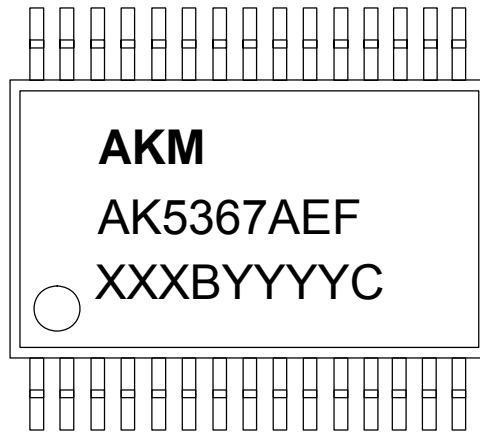

XXXBYYYYC Date code identifier

XXXB: Lot number (X: Digit number, B: Alpha character)
 YYYYYC: Assembly date (Y: Digit number, C: Alpha character)

REVISION HISTORY

Date (YY/MM/DD)	Revision	Reason	Page	Contents
08/05/23	00	First Edition		
09/05/21	01	Description Addition	27	PACKAGE An angle was added in the package drawing. (Detail A)

IMPORTANT NOTICE

- These products and their specifications are subject to change without notice.
When you consider any use or application of these products, please make inquiries the sales office of Asahi Kasei Microdevices Corporation (AKM) or authorized distributors as to current status of the products.
- AKM assumes no liability for infringement of any patent, intellectual property, or other rights in the application or use of any information contained herein.
- Any export of these products, or devices or systems containing them, may require an export license or other official approval under the law and regulations of the country of export pertaining to customs and tariffs, currency exchange, or strategic materials.
- AKM products are neither intended nor authorized for use as critical components^{Note1)} in any safety, life support, or other hazard related device or system^{Note2)}, and AKM assumes no responsibility for such use, except for the use approved with the express written consent by Representative Director of AKM. As used here:
 - Note1) A critical component is one whose failure to function or perform may reasonably be expected to result, whether directly or indirectly, in the loss of the safety or effectiveness of the device or system containing it, and which must therefore meet very high standards of performance and reliability.
 - Note2) A hazard related device or system is one designed or intended for life support or maintenance of safety or for applications in medicine, aerospace, nuclear energy, or other fields, in which its failure to function or perform may reasonably be expected to result in loss of life or in significant injury or damage to person or property.
- It is the responsibility of the buyer or distributor of AKM products, who distributes, disposes of, or otherwise places the product with a third party, to notify such third party in advance of the above content and conditions, and the buyer or distributor agrees to assume any and all responsibility and liability for and hold AKM harmless from any and all claims arising from the use of said product in the absence of such notification.