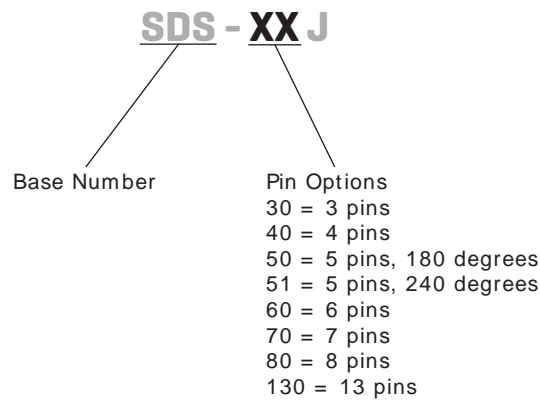

SERIES: SDS-XXJ | **DESCRIPTION:** STANDARD DIN CONNECTOR

FEATURES

- PCB mount
- right angle
- 3~8, 13 pins

PART NUMBER KEY

SPECIFICATIONS

parameter	conditions/description	min	typ	max	units
rated input voltage	all models		100		Vac
	130 model		12		Vdc
	all other models		24		Vdc
rated input current	130 model, at 100 Vac			1	A
	all other models, at 100 Vac			2	A
	130 model, at 12 Vdc			2	A
	all other models, at 24 Vdc			1	A
contact resistance				20	mΩ
insulation resistance	at 500 Vdc	100			MΩ
voltage withstand	for 1 minute			500	Vac
insertion force	130 model			3	kg
	all other models			5	kg
withdrawal force	40 model	0.6		3	kg
	130 model	0.5		2	kg
	all other models	1		3.5	kg
operating temperature		-40		85	°C
life			1,000		cycles

MECHANICAL DRAWINGS

units: mm[inches]

TOLERANCE: ± 0.2mm

	MATERIAL	PLATING
earth terminal (30~ 80)	phosphor bronze	tin
earth terminal (130)	phosphor bronze	silver
contact terminals (30~ 80)	brass	tin
contact terminals (130)	phosphor bronze	silver
plate (30~ 60)	bakelite	
plate (70, 80, 130)	N/A	
plastic	PBT	

SDS-30J

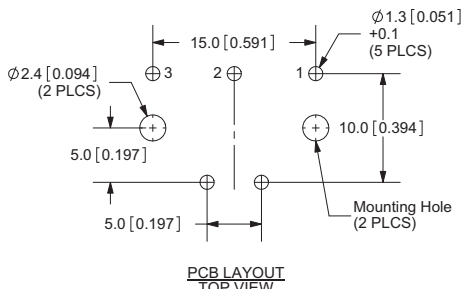
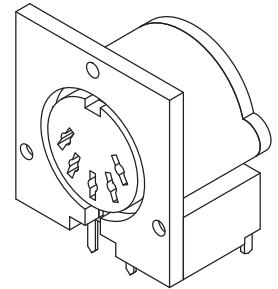
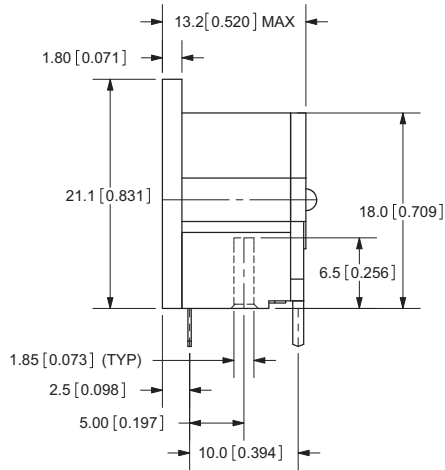
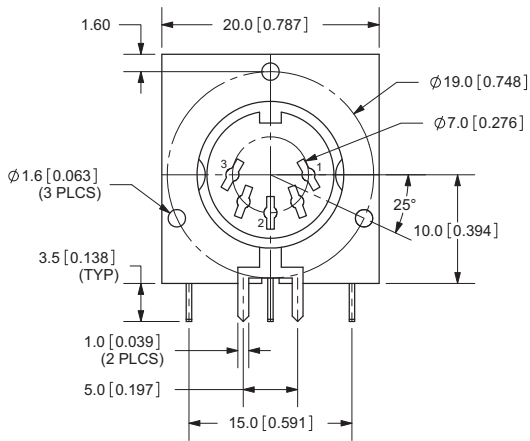

SDS-51J

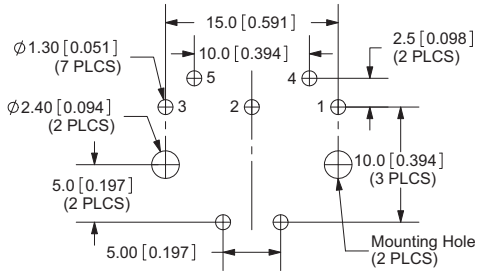
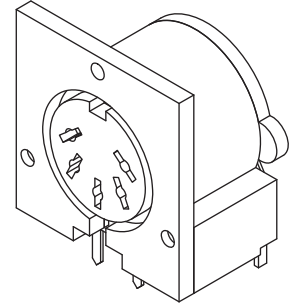
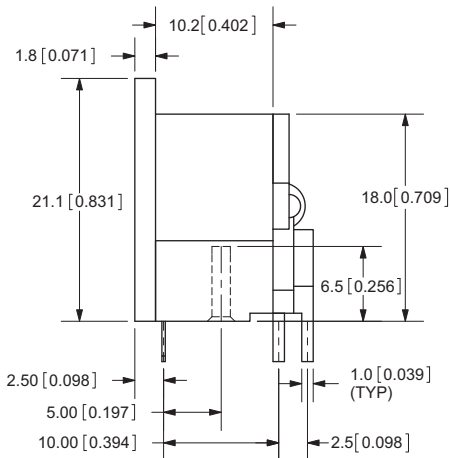
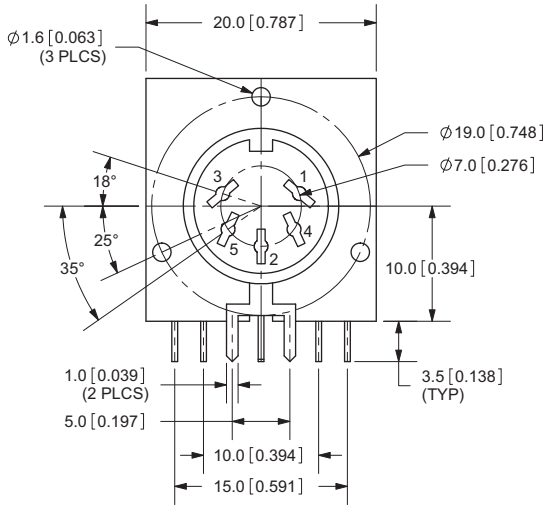

PCB LAYOUT

SDS-60J

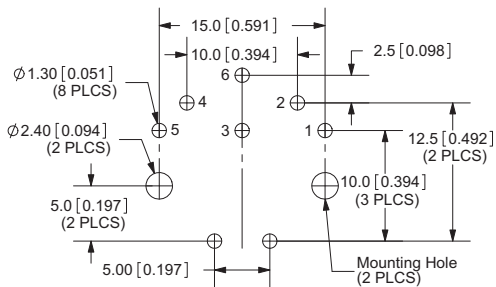
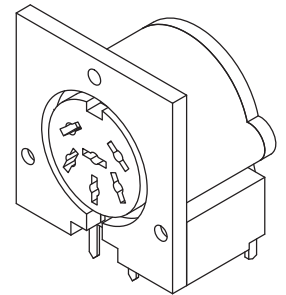
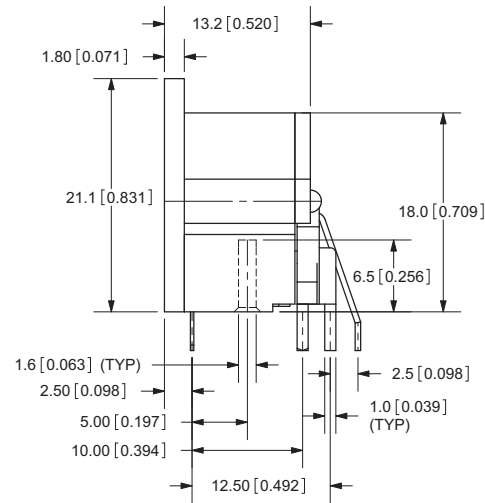
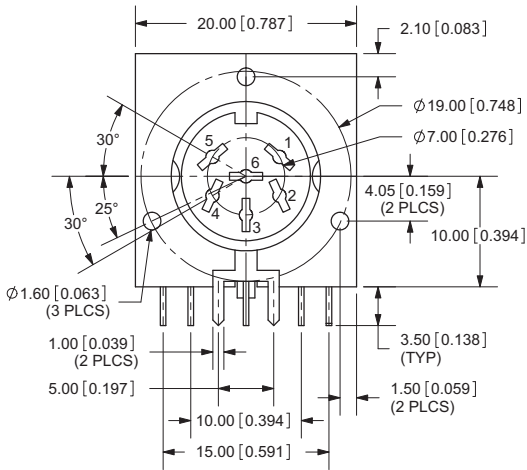

PCB LAYOUT
TOP VIEW

SDS-70J

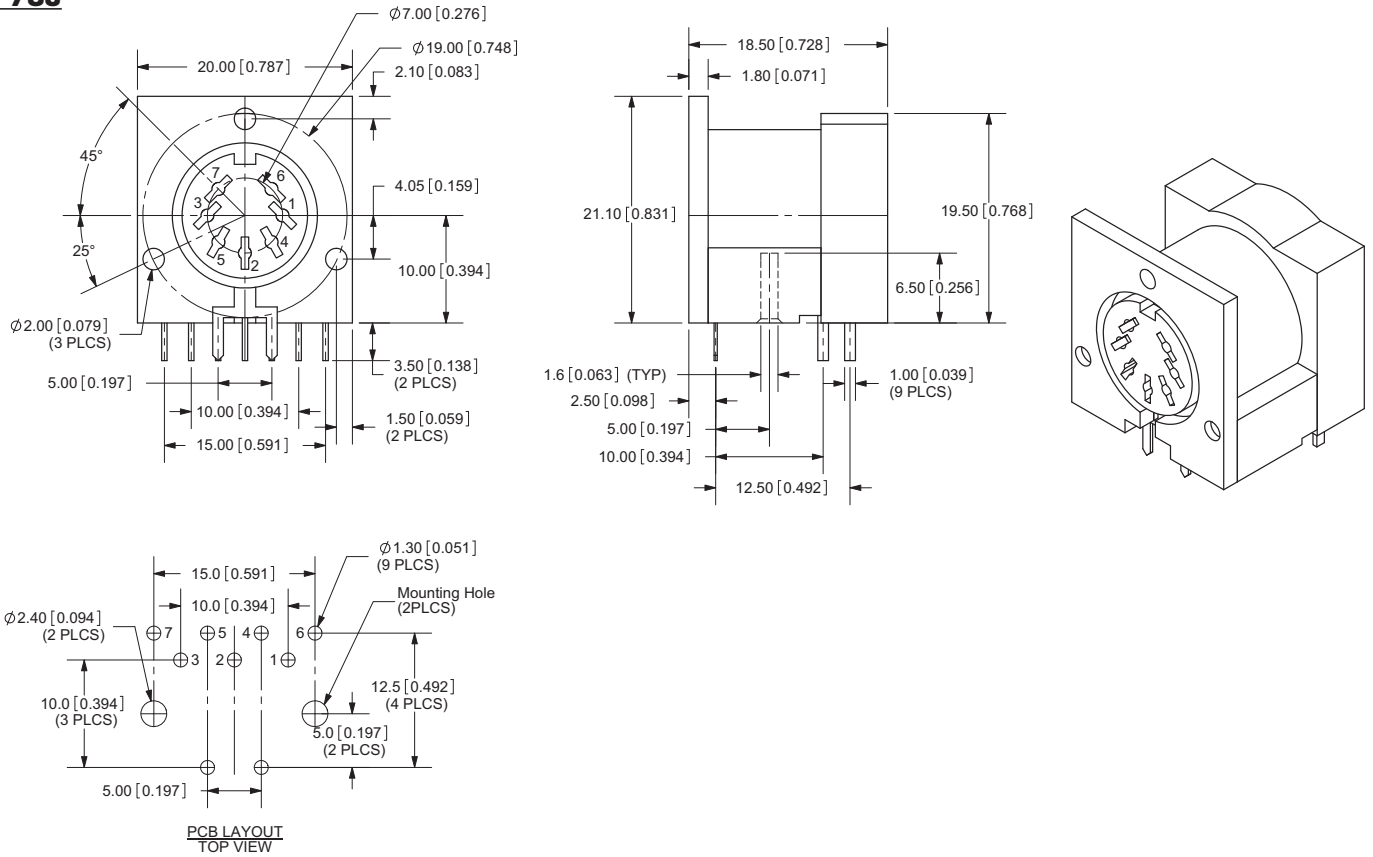

SDS-80J

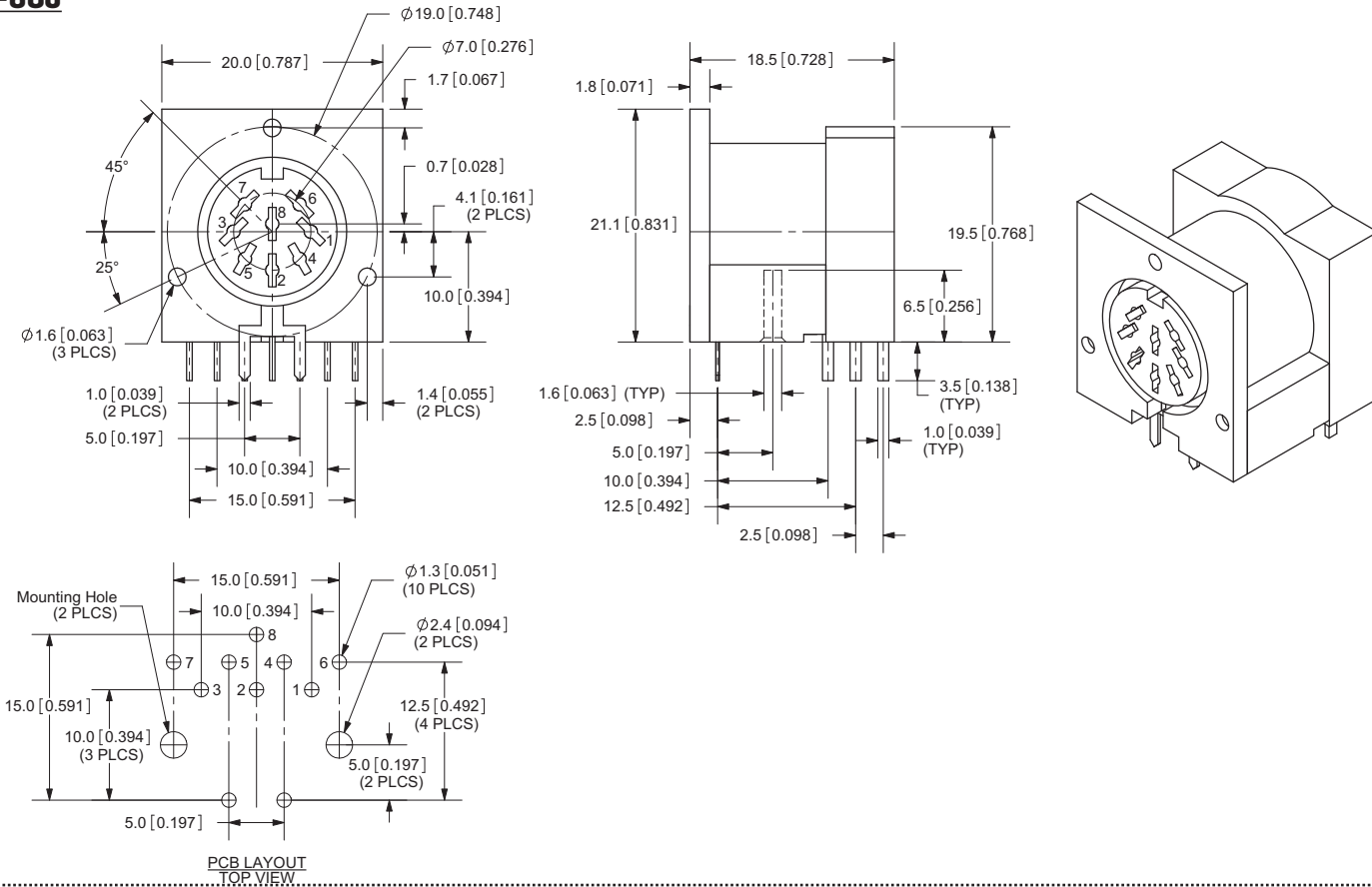

SDD-130J

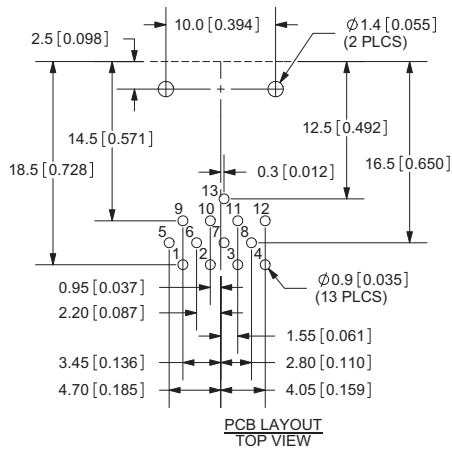
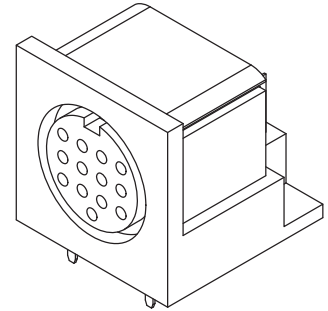
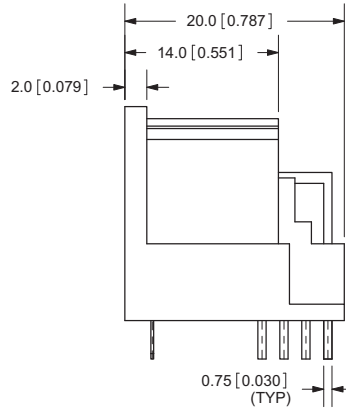
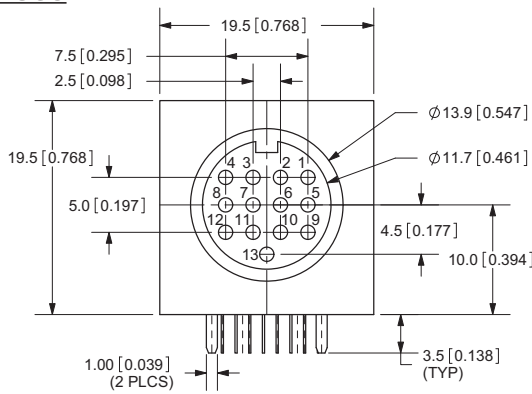

REVISION HISTORY

rev.	description	date
1.0	initial release	02/23/2006
1.01	new template applied	04/26/2012

The revision history provided is for informational purposes only and is believed to be accurate.



Headquarters
20050 SW 112th Ave.
Tualatin, OR 97062
800.275.4899

Fax 503.612.2383
cui.com
techsupport@cui.com

CUI offers a one (1) year limited warranty. Complete warranty information is listed on our website.

CUI reserves the right to make changes to the product at any time without notice. Information provided by CUI is believed to be accurate and reliable. However, no responsibility is assumed by CUI for its use, nor for any infringements of patents or other rights of third parties which may result from its use.

CUI products are not authorized or warranted for use as critical components in equipment that requires an extremely high level of reliability. A critical component is any component of a life support device or system whose failure to perform can be reasonably expected to cause the failure of the life support device or system, or to affect its safety or effectiveness.