

**SERIES:** VWRBT1 | **DESCRIPTION:** DC-DC CONVERTER

**FEATURES**

- 1 W isolated output
- wide input (2:1)
- industry standard 16 pin SMT package style
- single regulated outputs
- 1,500 V isolation
- short circuit protection
- wide temperature (-40~85°C)
- efficiency up to 80%



MODEL	input voltage		output voltage (Vdc)	output current		output power max (W)	ripple <sup>1</sup> max (mVp-p)	noise <sup>1</sup> max (mVp-p)	efficiency typ (%)
	typ (Vdc)	range (Vdc)		min (mA)	max (mA)				
VWRBT1-D12-S3.3-SMT	12	9~18	3.3	30	303	1	30	80	69
VWRBT1-D12-S5-SMT	12	9~18	5	20	200	1	30	80	72
VWRBT1-D12-S9-SMT	12	9~18	9	11	111	1	30	80	74
VWRBT1-D12-S12-SMT	12	9~18	12	8	83	1	30	80	75
VWRBT1-D12-S15-SMT	12	9~18	15	6	67	1	30	80	76
VWRBT1-D24-S3.3-SMT	24	18~36	3.3	30	303	1	30	80	70
VWRBT1-D24-S5-SMT	24	18~36	5	20	200	1	30	80	74
VWRBT1-D24-S9-SMT	24	18~36	9	11	111	1	30	80	76
VWRBT1-D24-S12-SMT	24	18~36	12	8	83	1	30	80	78
VWRBT1-D24-S15-SMT	24	18~36	15	6	67	1	30	80	78

Notes: 1. ripple and noise are measured at 20 MHz BW

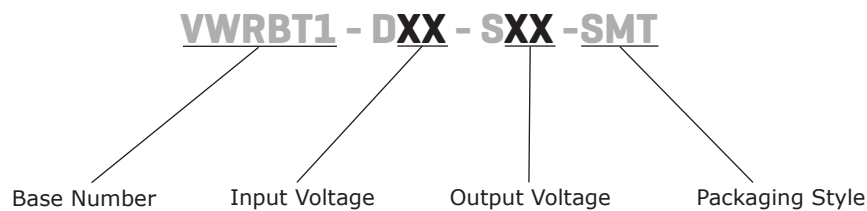
**PART NUMBER KEY**

**INPUT**

parameter	conditions/description	min	typ	max	units
operating input voltage	12 V model	9	12	18	Vdc
	24 V model	18	24	36	Vdc

**OUTPUT**

parameter	conditions/description	min	typ	max	units
line regulation	measured from low line to high line		±0.2	±0.5	%
load regulation	measured from 10% to 100% full load		±0.5	±1	%
voltage accuracy			±1	±2	%
switching frequency	100% load, nominal input voltage		300		kHz
temperature coefficient				±0.03	%/°C

**PROTECTIONS**

parameter	conditions/description	min	typ	max	units
short circuit protection	continuous				

**SAFETY AND COMPLIANCE**

parameter	conditions/description	min	typ	max	units
isolation voltage	tested for 1 minute, at 1 mA max.	1,500			Vdc
insulation resistance	at 500 Vdc	1,000			MΩ
isolation capacitance	input to output		85		pF
RoHS compliant	yes				
MTBF		1,000,000			hours

**ENVIRONMENTAL**

parameter	conditions/description	min	typ	max	units
operating temperature		-40		85	°C
storage temperature		-55		125	°C
storage humidity	non-condensing			95	%
temperature rise	at full load		15	30	°C
lead temperature	for 10 seconds			245	°C

## DERATING CURVES

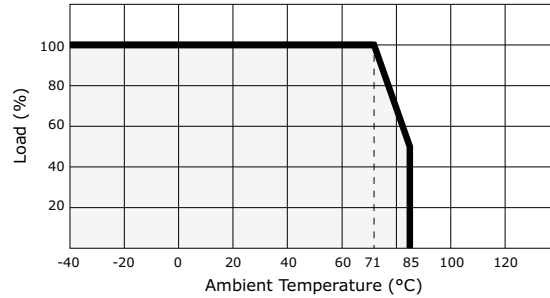

## MECHANICAL

parameter	conditions/description	min	typ	max	units
dimensions	0.939 x 0.539 x 0.299 (23.86 x 13.70 x 7.60 mm)				inch
case material	plastic (UL94-V0)				
weight			5.2		g

## MECHANICAL DRAWING

units: mm [inches]  
 tolerance: ±0.25 [±0.010]  
 pin section tolerance: ±0.10 mm [±0.004]

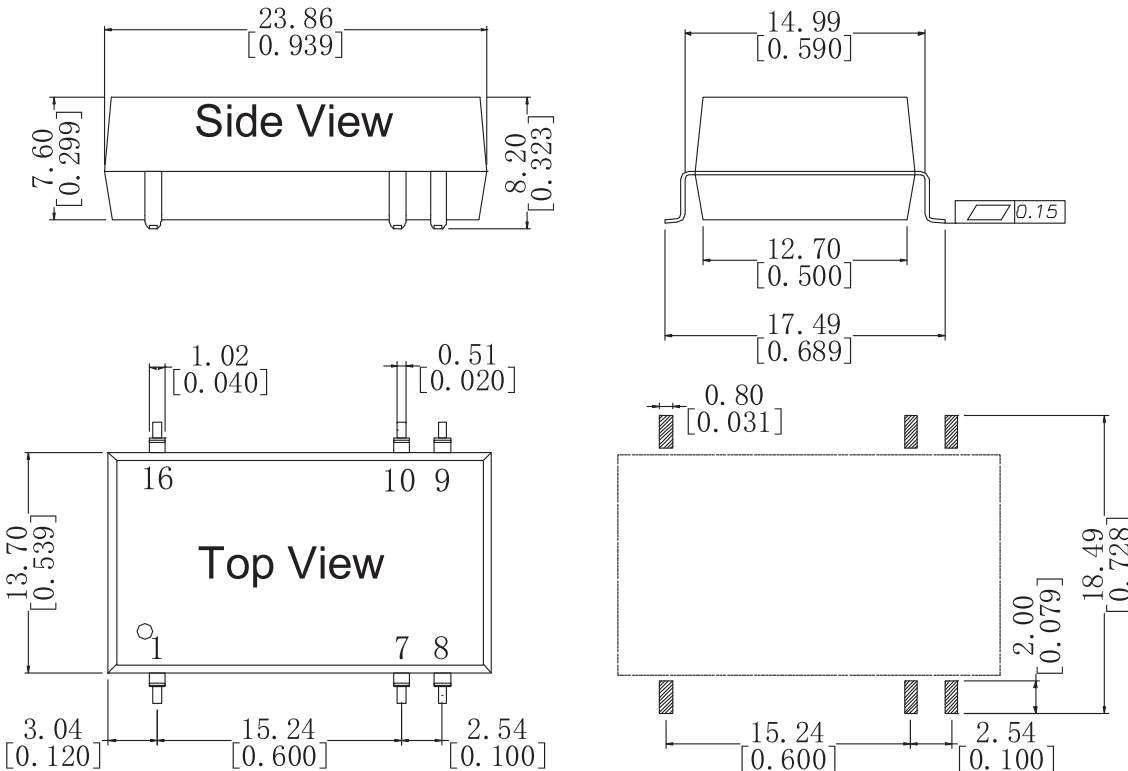

## APPLICATION NOTES

-All of the VWRBT1-SMT Series have been tested according to the following recommended testing circuit before leaving the factory. This series should be tested under load (Figure 1). If you want to further decrease the input/output ripple, you can increase capacitance properly or choose capacitors with low ESR. However, the capacitance should not be too high (Table 1).

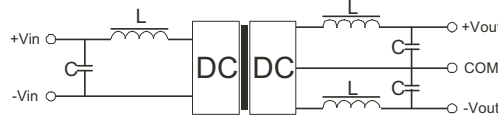

Figure 1

### 1. Recommended circuit

It is best to test with full load and not to test without load. To further reduce output ripple, you may increase the external capacitor, choose a capacitor with low ESR, or add external inductor to the circuit as shown above.

#### CS Pin

By connecting a low ESR capacitor between this terminal and the pin-7 (Figure 1), the output ripple and noise may be further improved. Generally, the capacitance is no greater than 47uF.

General:  $C_{in}$  &  $L_{in}$ : 22uF & 12uH

CS: 47uF(max)  $C_{out}$ :100uF

Table 1

Vout	$C_{out}/\mu F$ (max)	$C_s \mu F$
3.3 V	1000	47
5 V	470	47
9 V	330	47
12 V	150	47
15 V	100	47

### 2. Input current

Nominal input voltage range. The input current of the power supply must be sufficient to the startup current ( $I_p$ ) of the DC/DC module (Figure 2)

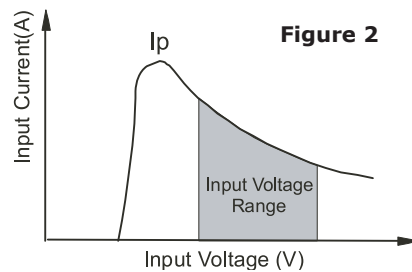

### 3. Output Load

In order to ensure the product operates efficiently and reliably, make sure the specified range of input voltage is not exceeded.

### 4. NC Terminals

Unless otherwise specified, NC terminals of all series are used for converter's interior circuit connection, and are not allowed connection of any external circuit.

**No parallel connection or plug and play.**

## REVISION HISTORY

---

rev.	description	date
1.0	initial release	01/11/2008
1.01	new template applied, V-Infinity branding removed	09/04/2012

The revision history provided is for informational purposes only and is believed to be accurate.



**CUI INC**<sup>®</sup>

**Headquarters**  
20050 SW 112th Ave.  
Tualatin, OR 97062  
**800.275.4899**

Fax 503.612.2383  
**cui.com**  
techsupport@cui.com

CUI offers a two (2) year limited warranty. Complete warranty information is listed on our website.

CUI reserves the right to make changes to the product at any time without notice. Information provided by CUI is believed to be accurate and reliable. However, no responsibility is assumed by CUI for its use, nor for any infringements of patents or other rights of third parties which may result from its use.

CUI products are not authorized or warranted for use as critical components in equipment that requires an extremely high level of reliability. A critical component is any component of a life support device or system whose failure to perform can be reasonably expected to cause the failure of the life support device or system, or to affect its safety or effectiveness.