



## FEATURES

- Low, Quiescent Current
- Guaranteed 300mA Output Current
- Over-Temperature Protection and Short-Circuit Protection
- Fixed Mode : 3.9V
- Ultra Low Supply Shutdown Current
- Stable with Low Cost Ceramic Capacitors
- RoHS Compliant & Halogen Free
- High PSRR

## APPLICATIONS

- Cellular Phones
- Notebook Computers
- PDAs
- Hand-Held Devices

## DESCRIPTION

APE8835 series are the positive linear regulators with very low quiescent current, can supply 300mA output current with a low dropout voltage.

Current limit is designed to ensure specified output current and controlled short-circuit current. On-chip over temperature limiting provides protection against overload that would create excessive junction temperatures.

APE8835 series may offer several fixed output voltage types and low-profile ,space-saving SOT-23-5L package.

## TYPICAL APPLICATION

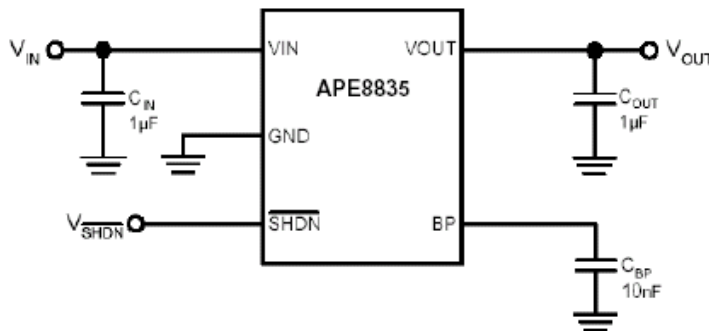

## ORDERING INFORMATION

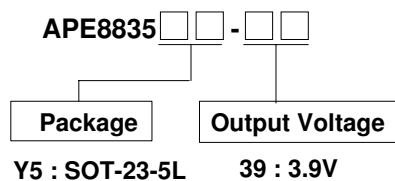



**ABSOLUTE MAXIMUM RATINGS** (at  $T_A=25^{\circ}\text{C}$ )

Input Voltage (VIN)	6V
Power Dissipation (SOT-23-5L)	0.4W
Storage Temperature Range	-65 to 150°C
Maximum Junction Temperature	150°C

**RECOMMENDED OPERATING CONDITIONS**

Input Voltage (VIN)	5V to 5.5V
Operating Junction Temperature Range	-40 to 125°C
Ambient Temperature	-40 to 85°C

**PACKAGE INFORMATION**

SOT-23-5L

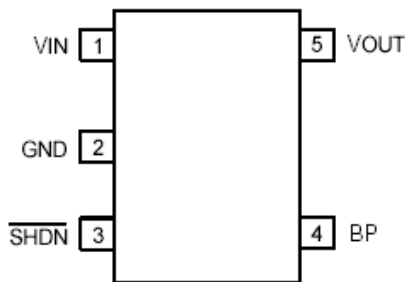

$R_{thja}=250^{\circ}\text{C/W}$

**ELECTRICAL SPECIFICATIONS**

( $V_{IN}=5\text{V}$ ,  $V_{SHDN}=V_{IN}$ ,  $T_A=25^{\circ}\text{C}$ ,  $C_{IN}=C_{OUT}=1\mu\text{F}$ , unless otherwise noted.)

PARAMETER	SYM	TEST CONDITION	MIN	TYP	MAX	UNITS
Output Voltage Accuracy(fixed)			-3.0	-	3.0	%
Max. Output Current			300	-	-	mA
Current Limit	$I_{LM}$		400	550	-	mA
Short Circuit Current	$I_{SC}$	$V_{OUT}<1.0\text{V}$	-	500	-	mA



**ELECTRICAL SPECIFICATIONS(Cont.)**

PARAMETER	SYM	TEST CONDITION	MIN	TYP	MAX	UNITS
Ground Pin Current	$I_Q$	$I_{OUT}=0mA, V_{IN}=5V$	-	80	-	$\mu A$
Dropout Voltage(Note1)	$V_{DROP}$	$V_{OUT}=3.9V, I_{OUT}=300mA$	-	0.25	0.5	V
Line Regulation	$\Delta V_{LNR}$	$V_{IN}=V_{OUT}+0.5V$ to 5.5V, $I_{OUT}=10mA$	-	0.06	0.12	%/V
Load Regulation(Note2)	$\Delta V_{LDR}$	$I_{OUT}=10mA$ to 300mA	-	-	0.02	%/mA
Ripple Rejection	PSRR	$I_O=1mA, C_{OUT}=1\mu F, f_{RIPPLE}=1KHZ$ $f_{RIPPLE}=10KHZ$	-	-65	-	dB
			-	-40	-	

**SHUTDOWN**

SHDN Input Thershold	$V_{IH}$	Regulator enabled	1.5	-	-	V
	$V_{IL}$	Regulator shutdown	-	-	0.4	
SHDN Input Bias Current	$I_{SHDN}$	$V_{SHDN}=V_{IN}, T_A=25^\circ C$	-	0.003	0.1	$\mu A$
Shutdown Supply Current	$I_{QSHDN}$	$V_{OUT}=0V, T_A=25^\circ C$	-	0.2	1	$\mu A$

**THERMAL PROTECTION**

Thermal Shutdown Temperature	$T_{SHDN}$		-	160	-	$^\circ C$
Thermal Shutdown Hysteresis	$\Delta T_{SHDN}$		-	32	-	$^\circ C$

Note1. 1 : The dropout voltage is defined as  $V_{IN}-V_{OUT}$ , which is measured when  $V_{OUT}$  drop about 100mV. junction temperature as close to ambient as possible.

Note2. Regulation is measured at a constant junction temperature by using pulse current and load regulation in the load range from 0mA to 300mA.

**PIN DESCRIPTIONS**

PIN SYMBOL	PIN DESCRIPTION
VIN	Power is supplied to this device from this pin which is required an input filter capacitor. In general, the input capacitor in the range of 1 $\mu F$ to 10 $\mu F$ is sufficient.
GND	Common ground pin
SHDN	Chip Enable (Active High)
BP	Reference Noise Bypass ( the Bypass Capacitor $\geq 1nF$ )
VOUT	The output supplies power to loads. The output capacitor is required to prevent output voltage unstable. The APE8835 is stable with an output capacitor 1 $\mu F$ or greater. The larger output capacitor will be required for application with large transit load to limit peak voltage transits, besides could reduce output noise, improve stability, PSRR.

**BLOCK DIAGRAM**

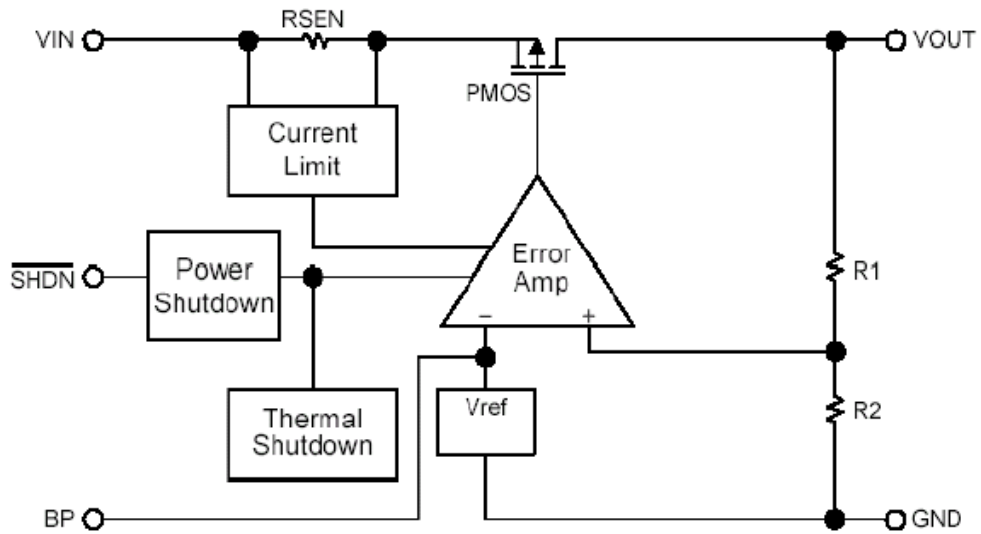



# TYPICAL PERFORMANCE CHARACTERISTICS

Line Regulation

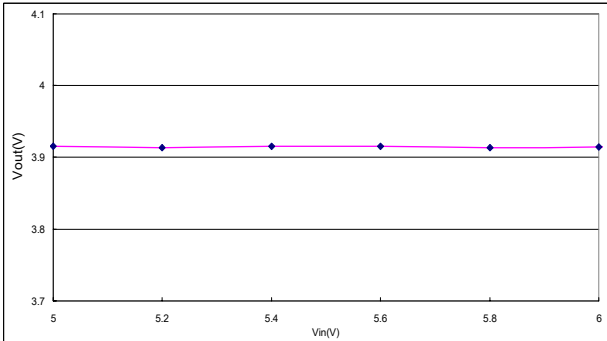

Load Regulation

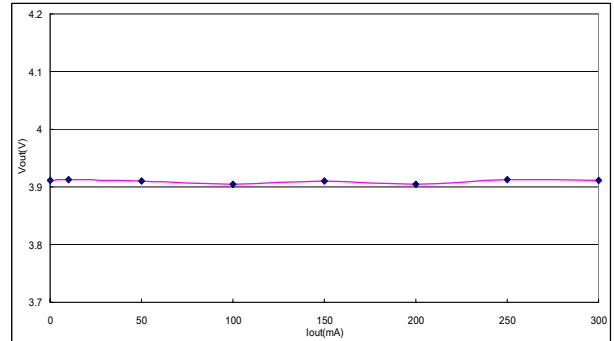

Load Transient

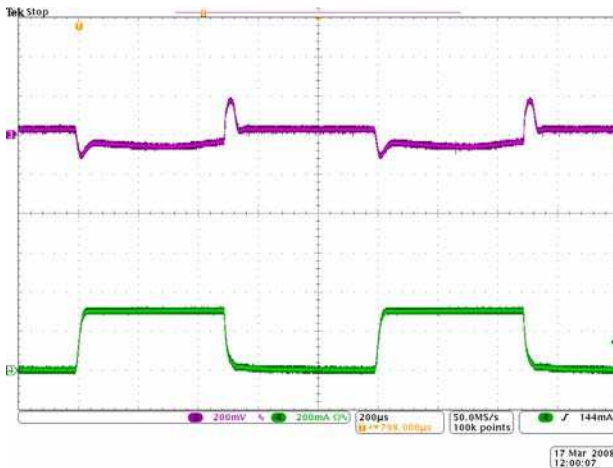

Short Circuit Current

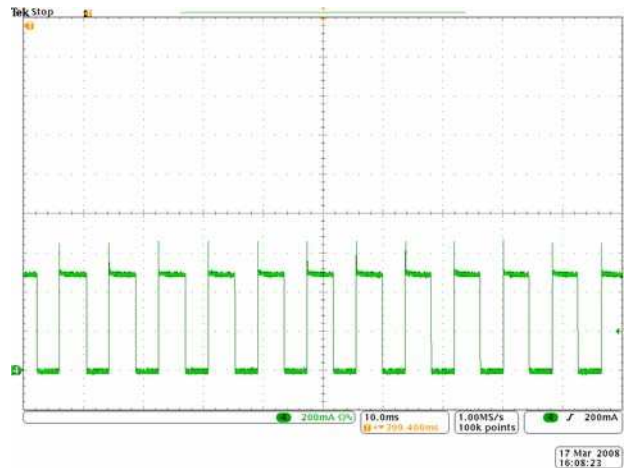

Turn-on

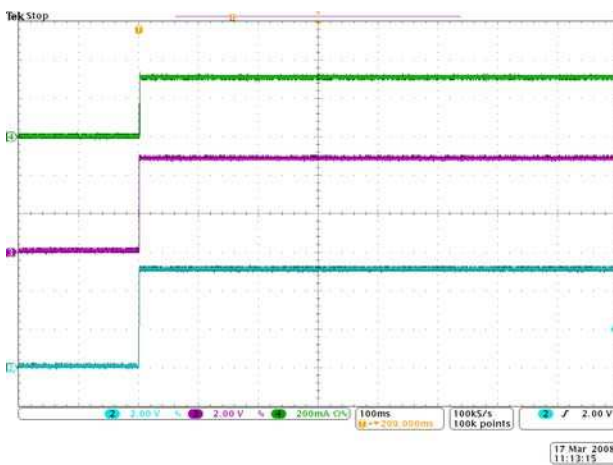

Turn-off

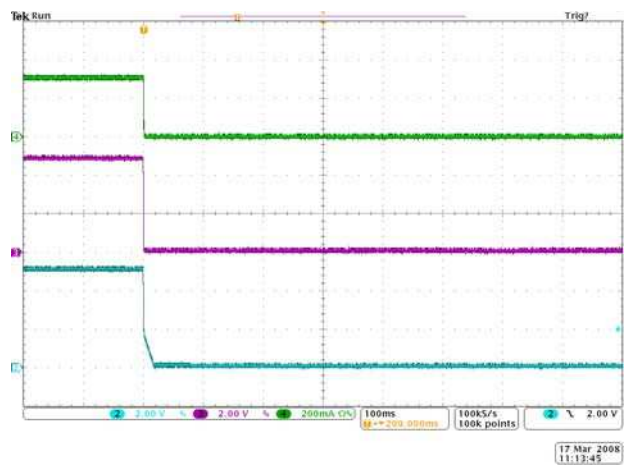



TYPICAL PERFORMANCE CHARACTERISTICS(Cont.)

Dropout Voltage vs.  $I_L$

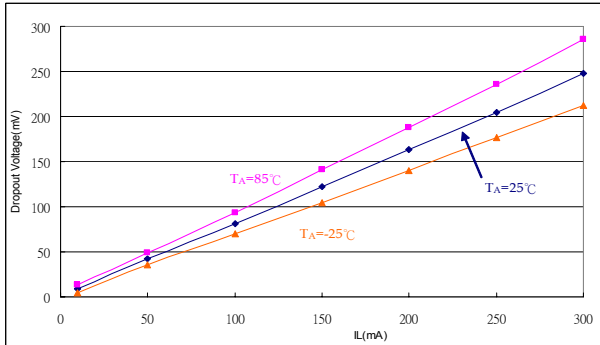

Output Voltage vs. Temperature

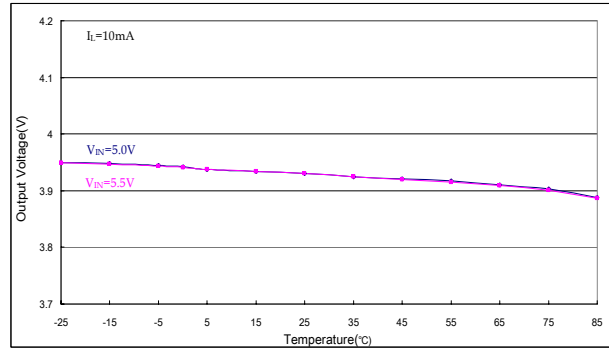



**Package Outline : SOT-23-5L**

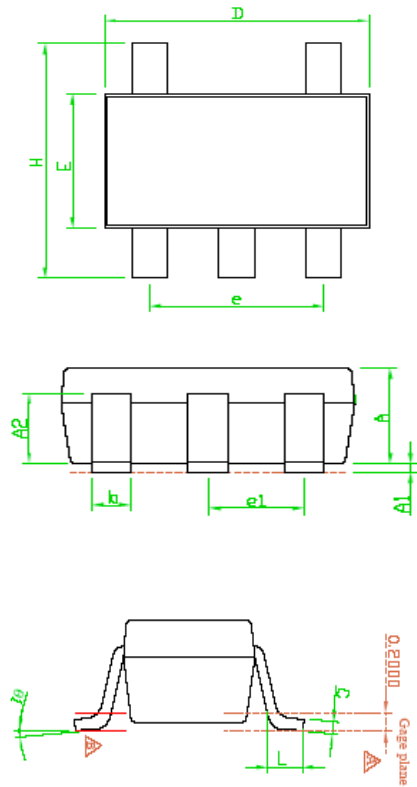

SYMBOLS	Millimeters		
	MIN	NOM	MAX
A	1.00	1.10	1.30
A1	0.00	---	0.10
A2	0.70	0.80	0.90
b	0.35	0.40	0.50
C	0.10	0.15	0.25
D	2.70	2.90	3.10
E	1.50	1.60	1.80
e	---	1.90(TYP)	---
H	2.60	2.80	3.00
L	0.37	---	---
$\theta 1$	1°	5°	9°
e2	---	0.95(TYP)	---

- Note 1 : Package Body Sizes Exclude Mold Flash Protrusions or Gate Burrs.
- Note 2 : Tolerance  $\pm 0.1000$  mm(4mil) Unless Otherwise Specified.
- Note 3 : Coplanarity : 0.1000 mm
- Note 4 : Dimension L Is Measured in Gage plane.

**Part Marking Information & Packing : SOT-23 -5L**

