



FEATURES

- Low, Quiescent Current
- Guaranteed 300mA Output Current
- Over-Temperature Protection and Short-Circuit Protection
- Fixed Mode : 4.75V
- Ultra Low Supply Shutdown Current
- Stable with Low Cost Ceramic Capacitors
- RoHS Compliant & Halogen Free
- High PSRR

APPLICATIONS

- Cellular Phones
- Notebook Computers
- PDAs
- Hand-Held Devices

DESCRIPTION

The APE8833 series are low dropout, positive linear regulators with very low quiescent current. The APE8833 can supply 300mA output current with a low dropout voltage.

The APE8833 regulator is able to operate with output capacitors as small as 1 μ F for stability. Other than the current limit protection APE8833 also offers on chip thermal shutdown feature providing protection against overload or any condition when the ambient temperature exceeds the junction temperature.

The APE8833 series are offering several fixed output voltage types and low-profile ,space-saving SOT-23-5L package.

TYPICAL APPLICATION

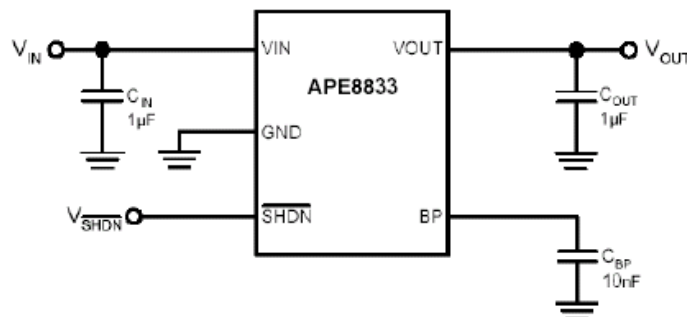

ORDERING INFORMATIO





ABSOLUTE MAXIMUM RATINGS (at $T_A=25^\circ\text{C}$)

Input Voltage (VIN)	6V
Power Dissipation (SOT-23-5L)	0.4W
Storage Temperature Range	-65 to 150°C
Maximum Junction Temperature	150°C

RECOMMENDED OPERATING CONDITIONS

Input Voltage (VIN)	5V to 5.5V
Operating Junction Temperature Range	-40 to 125°C
Ambient Temperature	-40 to 85°C

PACKAGE INFORMATION

SOT-23-5L

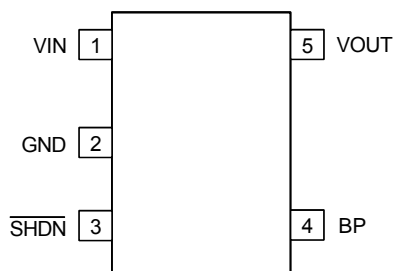

$R_{thja}=250^\circ\text{C/W}$

ELECTRICAL SPECIFICATIONS

($V_{IN}=5\text{V}$, $V_{SHDN}=V_{IN}$, $T_A=25^\circ\text{C}$, $C_{IN}=C_{OUT}=1\mu\text{F}$, unless otherwise noted.)

Parameter	SYM	TEST CONDITION	MIN	TYP	MAX	UNITS
Input Voltage	V_{IN}		5	-	6	V
Output Voltage Accuracy(fixed)			-3.0	-	3.0	%
Max. Output Current			300	-	-	mA
Current Limit	I_{LM}		400	550	-	mA
Short Circuit Current	I_{SC}	$V_{OUT}<1.0\text{V}$	-	500	-	mA



ELECTRICAL SPECIFICATIONS(Cont.)

Parameter	SYM	TEST CONDITION	MIN	TYP	MAX	UNITS
Ground Pin Current	I_Q	$I_{OUT}=0mA, V_{IN}=5V$	-	80	-	μA
Dropout Voltage(Note1)	V_{DROP}	$V_{OUT}=4.75V, I_{OUT}=300mA$	-	0.25	0.5	V
Line Regulation	ΔV_{LNR}	$V_{IN}=V_{OUT}+0.5V$ to $5.5V, I_{OUT}=10mA$	-	0.06	0.12	%/V
Load Regulation(Note2)	ΔV_{LDR}	$I_{OUT}=10mA$ to $300mA$	-	-	0.02	%/mA
Ripple Rejection	PSRR	$I_O=1mA, C_{OUT}=1\mu F, f_{RIPPLE}=1KHz$ $f_{RIPPLE}=10KHz$	-	-65	-	dB
			-	-40	-	

SHUTDOWN

SHDN Input Thershold	V_{IH}	Regulator enabled	1.5	-	-	V
	V_{IL}	Regulator shutdown	-	-	0.4	
SHDN Input Bias Current	I_{SHDN}	$V_{SHDN}=V_{IN}, T_A=25^\circ C$	-	0.003	0.1	μA
Shutdown Supply Current	I_{QSHDN}	$V_{OUT}=0V, T_A=25^\circ C$	-	0.2	1	μA

THERMAL PROTECTION

Thermal Shutdown Temperature	T_{SHDN}		-	160	-	$^\circ C$
Thermal Shutdown Hysteresis	ΔT_{SHDN}		-	32	-	$^\circ C$

Note1. 1 : The dropout voltage is defined as $V_{IN}-V_{OUT}$, which is measured when V_{OUT} drop about 100mV. junction temperature as close to ambient as possible.

Note2. Regulation is measured at a constant junction temperature by using 30ms current pulse and load regulation in the load range from 0mA to 300mA.

PIN DESCRIPTIONS

PIN SYMBOL	PIN DESCRIPTION
VIN	Power is supplied to this device from this pin which is required an input filter capacitor. In general, the input capacitor in the range of $1\mu F$ to $10\mu F$ is sufficient.
GND	Common ground pin
SHDN	Chip Enable (Active High)
BP	Reference Noise Bypass (the Bypass Capacitor $\geq 1nF$)
VOUT	The output supplies power to loads. The output capacitor is required to prevent output voltage unstable. The APE8833 is stable with an output capacitor $1\mu F$ or greater. The larger output capacitor will be required for application with large transit load to limit peak voltage transits, besides could reduce output noise, improve stability, PSRR.



BLOCK DIAGRAM

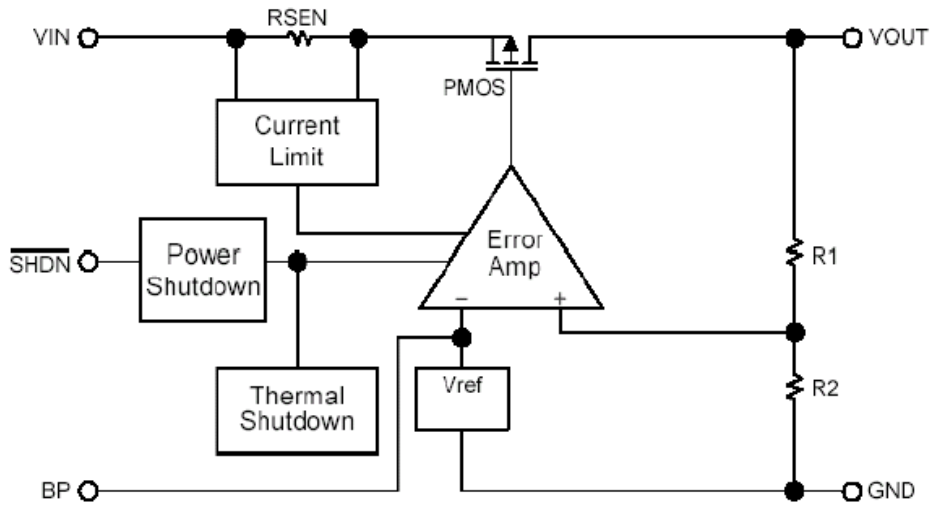



TYPICAL PERFORMANCE CHARACTERISTICS

Line Regulation

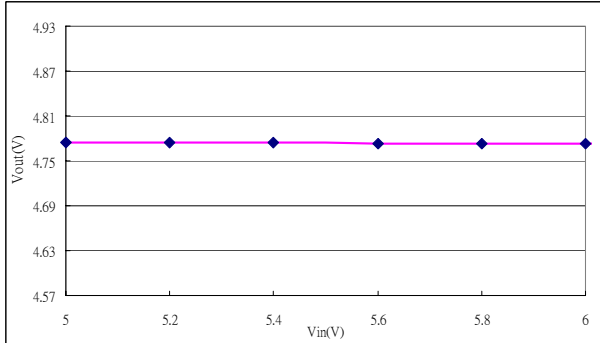

Load Regulation

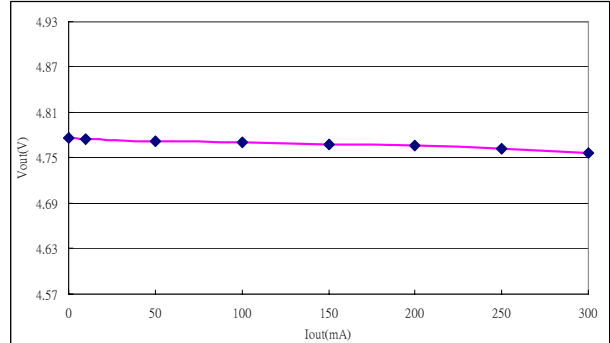

Load Transient

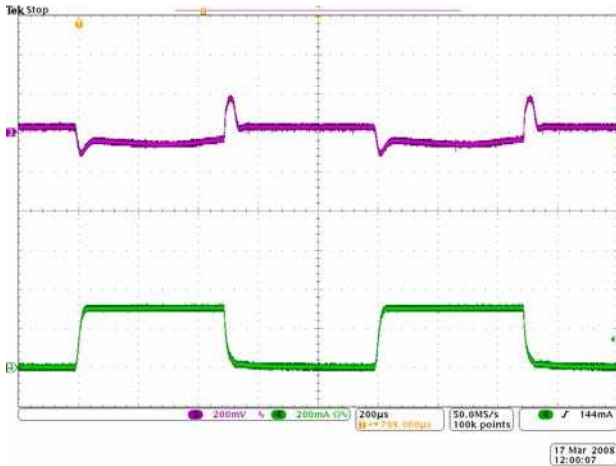

Short Circuit Current

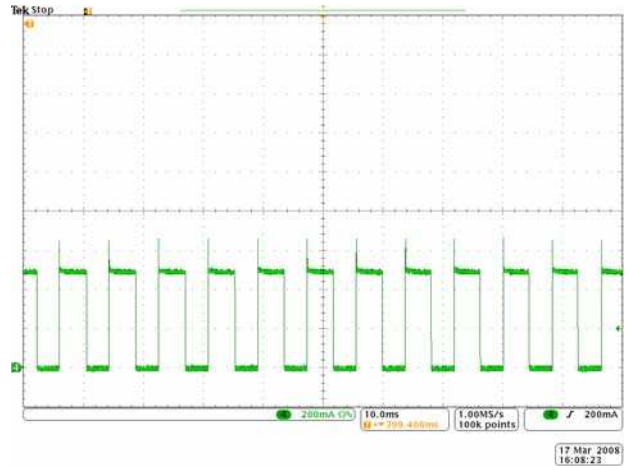

Turn-on

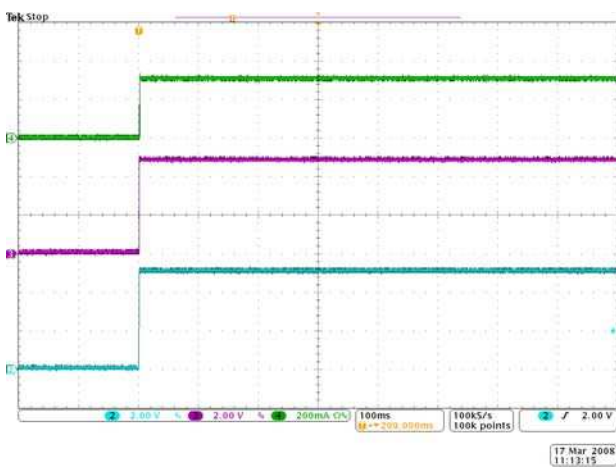

Turn-off

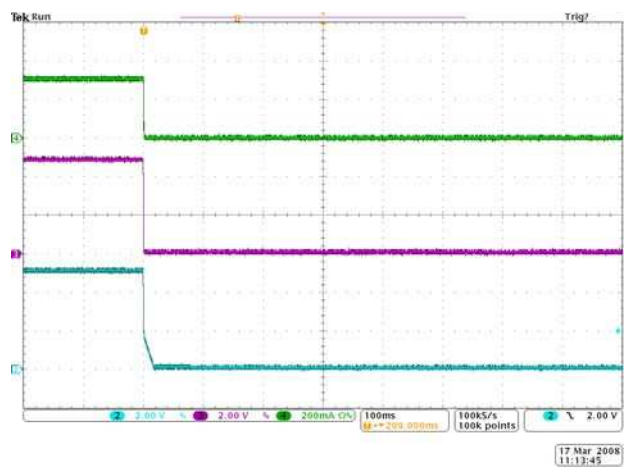



TYPICAL PERFORMANCE CHARACTERISTICS(Cont.)

Dropout Voltage vs. I_L

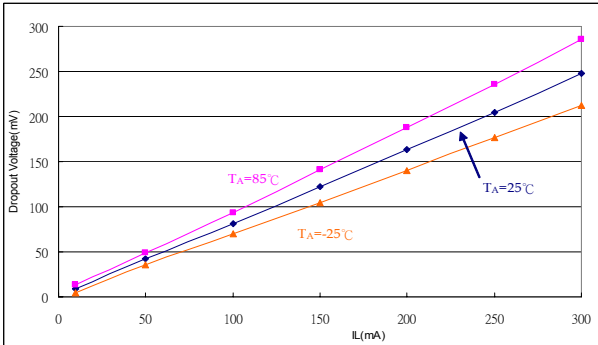

Output Voltage vs. Temperature

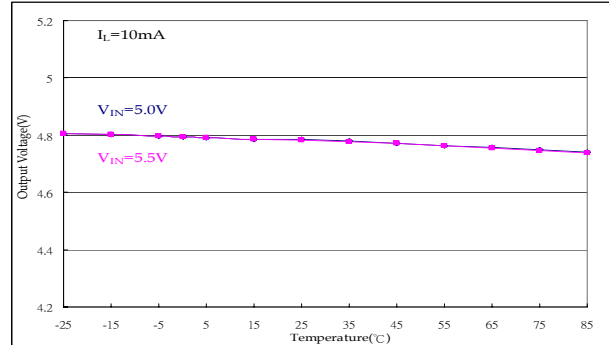



Package Outline : SOT-23-5L

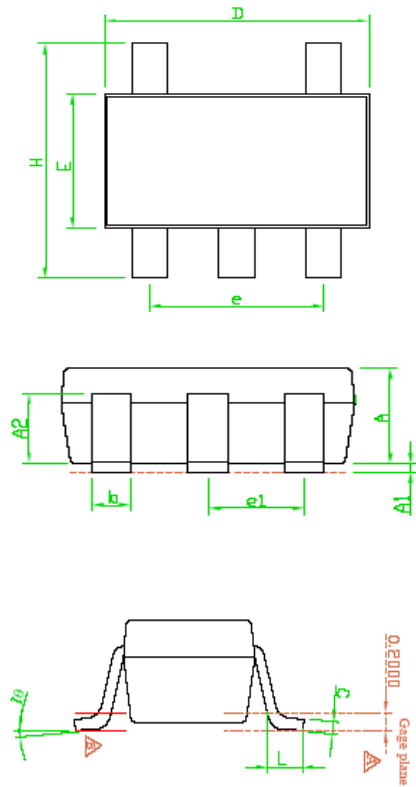

SYMBOLS	Millimeters		
	MIN	NOM	MAX
A	1.00	1.10	1.30
A1	0.00	---	0.10
A2	0.70	0.80	0.90
b	0.35	0.40	0.50
C	0.10	0.15	0.25
D	2.70	2.90	3.10
E	1.50	1.60	1.80
e	---	1.90(TYP)	---
H	2.60	2.80	3.00
L	0.37	---	---
$\theta 1$	1°	5°	9°
e2	---	0.95(TYP)	---

- Note 1 : Package Body Sizes Exclude Mold Flash Protrusions or Gate Burrs.
- Note 2 : Tolerance ± 0.1000 mm(4mil) Unless Otherwise Specified.
- Note 3 : Coplanarity : 0.1000 mm
- Note 4 : Dimension L Is Measured in Gage plane.

Part Marking Information & Packing : SOT-23 -5L

