



150mA ULTRA LOW DROPOUT POSITIVE ADJUSTABLE AND FIXED REGULATORS

FEATURES

- Stable with 2.2uF Low ESR Ceramic Capacitor
- 2% Voltage Reference Accuracy
- Wide Operating Range: 4.5V ~ 25V
- 5uA Quiescent Current in Shutdown
- Current Limit and Thermal Shutdown
- Logic Input Enable Pin
- RoHS Compliant & Halogen Free
- SOT-89, ESOP-8, J-lead 2021-8, SOT-23-5L & TSOT-23-5L Package

DESCRIPTION

The APU8850 device is an efficient linear voltage regulator with better than 2% initial voltage accuracy, very low dropout voltage and very low ground current designed especially for hand held, battery powered applications. Other features of the device are: TTL compatible enable/shutdown control input, current limiting and thermal shutdown.

The APU8850 is available in fixed and adjustable output voltage versions in a small SOT-23-5L, TSOT-23-5L, J-lead 2021-8, ESOP-8 & SOT-89 package.

APPLICATIONS

- Laptop, Notebook & Palmtop Computers
- Battery Powered Equipments
- PCMCIA Vcc & Vpp Regulator
- Consumer Electronics
- High Efficiency Linear Power Supplies

TYPICAL APPLICATION

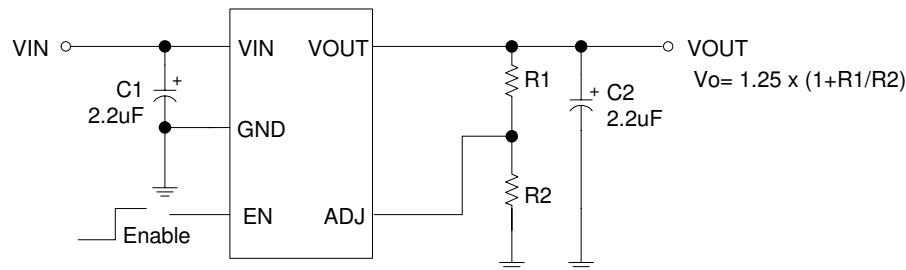

Figure 1 - Typical application of the APU8850 adjustable voltage regulator.

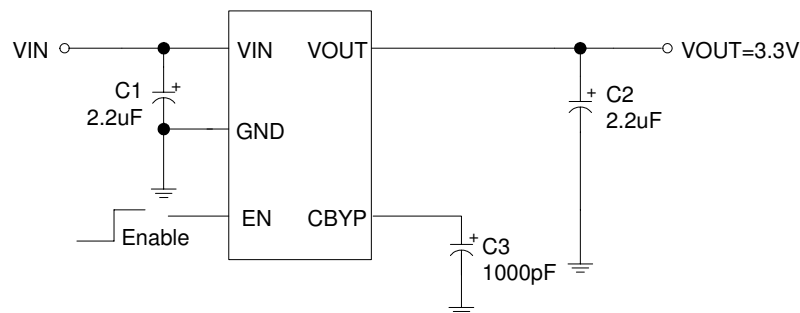

Figure 2 - Typical application of the APU8850-33 fixed voltage regulator.

ORDERING INFORMATION

APU8850X-XX-HF ← Halogen Free

Package	Output Voltage
Y5 : SOT-23-5L	Blank : ADJ
TY5 : TSOT-23-5L	15 : 1.5V
U : J-lead 2021-8	18 : 1.8V
G : SOT-89	25 : 2.5V
MP : ESOP-8	28 : 2.8V
	30 : 3.0V
	33 : 3.3V
	50 : 5.0V

ABSOLUTE MAXIMUM RATINGS ($T_A=25^{\circ}\text{C}$, unless otherwise specified.)

Input Voltage (V_{IN})	27V
Enable Input Voltage (V_{EN})	27V
Storage Temperature Range (T_{ST})	-65 to 150°C
Operating Junction Temperature Range (T_J)	-40 to 85°C
Thermal Resistance Junction to Ambient (R_{thja})	
SOT-23-5L/TSOT-23-5L	256°C/W
SOT-89	250°C/W
ESOP-8	150°C/W
J-lead 2021-8	300°C/W

PACKAGE INFORMATION

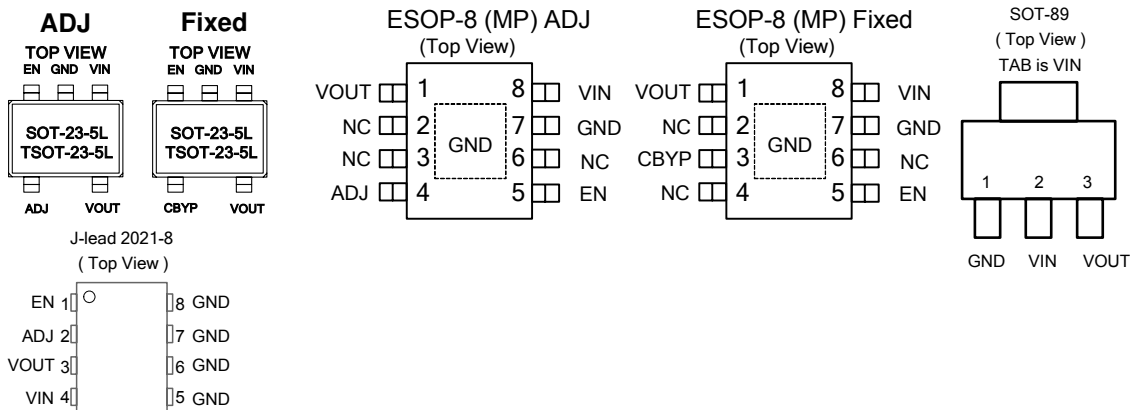

ELECTRICAL SPECIFICATIONS

Unless otherwise specified, these specifications apply over $C_{IN}=C_O=2.2\text{F}$, $I_O=100\mu\text{A}$, $V_{IN(MIN)}=4.5\text{V}$, $C_{BYP}=470\text{pF}$ (for fixed voltage devices), $V_{EN}=2\text{V}$ and $T_A=25^{\circ}\text{C}$. Typical values refer to $T_A=25^{\circ}\text{C}$. Low duty cycle pulse testing is used which keeps junction and case temperatures equal to the ambient temperature.

Parameter	SYM	TEST CONDITION	MIN	TYP	MAX	UNITS
Reference Voltage	V_O		-2	-	2	%
Line Regulation	ΔV_L	$V_O + 2\text{V} < V_{IN} < 25\text{V}$, $I_O=1\text{mA}$	-	0.1	-	%/V
Load Regulation (Note 1)	ΔV_L	$V_{IN}=V_O+2\text{V}$	-	0.5	-	%
Dropout Voltage (Note 2)	V_{DROP}	$I_O=100\mu\text{A}$	-	1	-	V
		$I_O=100\text{mA}$	-	1.2	-	V
Ground Current (Note 3)	I_Q	$V_{EN}=2\text{V}$, $I_O=100\mu\text{A}$	-	250	-	μA
Ground Current-SD Activated	$I_{Q(SD)}$	$V_{EN}=0\text{V}$ or Open	-	1	-	μA
Adjust Pin Current	I_{ADJ}	$V_{IN}=4.5\text{V}$, $V_O=V_{ADJ}$	-	0.1	-	μA
Current Limit	I_{CL}		200	-	-	mA
Short Current	I_Z	$V_O=0\text{V}$	-	175	-	mA
Enable Pin Input LO Voltage	$V_{EN(L)}$	Regulator OFF	-	-	0.8	V
Enable Pin Input HI Voltage	$V_{EN(H)}$	Regulator ON	2	-	-	V
Enable Pin Input LO Current		$V_{EN(L)}=0\text{V}$	-	0.01	-	μA
Enable Pin Input HI Current		$V_{EN(H)}=2\text{V}$	-	10	-	μA
Ripple Rejection	PSRR	$C_{BYP}=1\text{nF}$, $C_O=2.2\mu\text{F}$, $f_{RIPPLE}=1\text{kHz}$	-	70	-	dB
Over Temperature Shutdown			-	150	-	$^{\circ}\text{C}$
Over Temperature Shutdown Hysteresis			-	10	-	$^{\circ}\text{C}$

Note 1: Low duty cycle pulse testing with Kelvin connections is required in order to maintain accurate data.

Note 2: Dropout voltage is defined as the minimum differential voltage between V_{IN} and V_{OUT} required to maintain regulation at V_{OUT} .

It is measured when the output voltage drops 1% below its nominal value.

Note 3: Ground current is the regulator quiescent current plus the pass transistor current. The total current from the supply is the sum of the load current plus the ground pin current.



PIN DESCRIPTIONS

PIN SYMBOL	PIN DESCRIPTION
VIN	The input pin of the regulator. Typically a large storage capacitor is connected from this pin to ground to insure that the input voltage does not sag below the minimum drop out voltage during the load transient response. This pin must always be higher than VOUT by at least the amount of the dropout voltage and some margin in order for the device to regulate properly.
GND	Ground pin. This pin must be connected to the lowest potential in the system and all other pins must be at higher potential with respect to this pin.
EN	Enable pin. A low signal or left open on this pin shuts down the output. This pin must be tied HI or to VIN for normal operation.
Adj (Adjustable only)	A resistor divider from this pin to the VOUT pin and ground sets the output voltage.
C _{BYP} (Fixed only)	A 470 to 1000pF bypass capacitor connected to this pin reduces the output noise.
VOUT	The output of the regulator. A minimum of 2.2uF with max ESR of 1 Ω capacitor must be connected from this pin to ground to insure stability.

BLOCK DIAGRAM

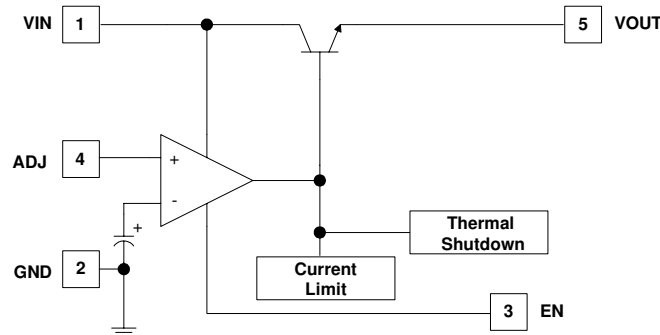

Figure 3 - APU8850Y5 Adjustable output block diagram.

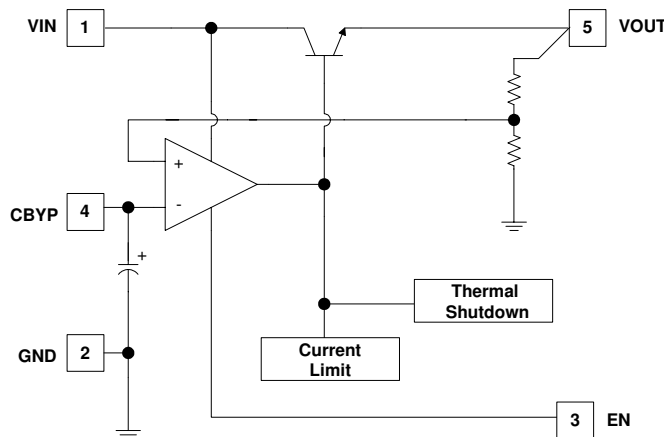

Figure 4 - APU8850Y5 Fixed Mode output block diagram.



TYPICAL PERFORMANCE CHARACTERISTICS

VIN=5V , VEN=5V , VOUT=3.3V

Output Voltage VS. Temperature

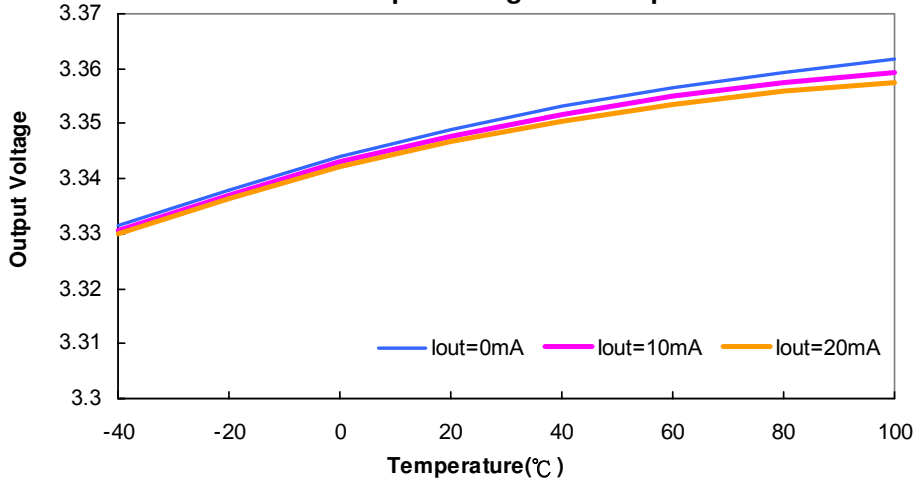

VIN=5V , VEN=5V , VOUT=3.3V

ADJ Voltage VS. Temperature

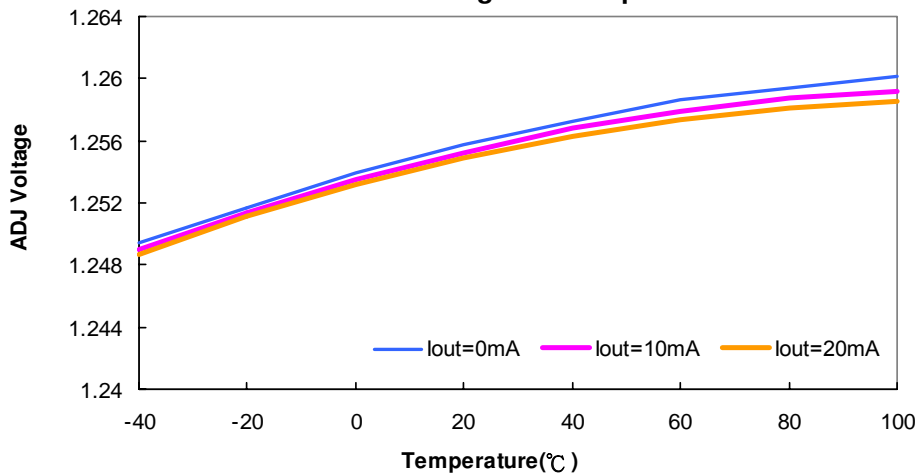

VIN=4.5V , VOUT=3.3V IOU=10mA~200mA

Load Transient

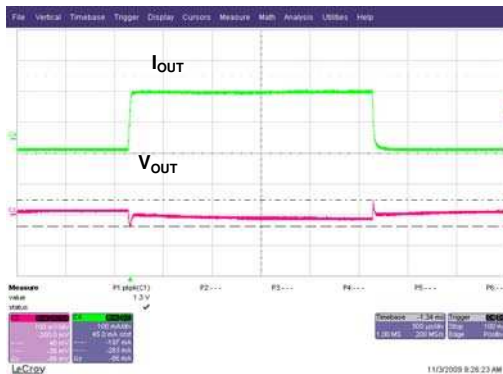



TYPICAL PERFORMANCE CHARACTERISTICS

Quiescent Current vs. Temperature
VIN=4.5V , VOUT=3.3V , IOU=10mA

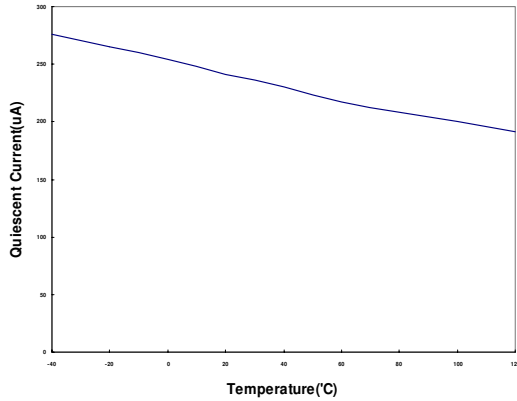

Quiescent Current vs. Input Voltage
VIN=4.5V~20V , VOUT=3.3V

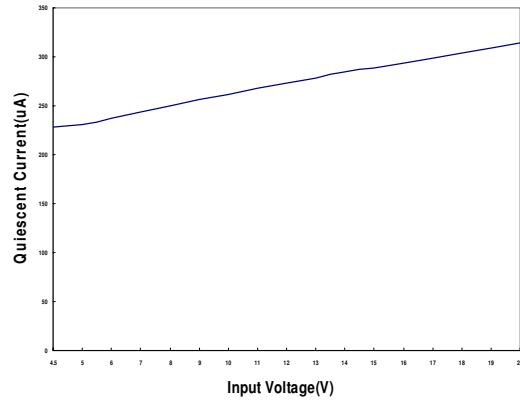

Output Voltage vs. Output Current
VIN=4.5V , VOUT=3.3V , IOU=10mA~200mA

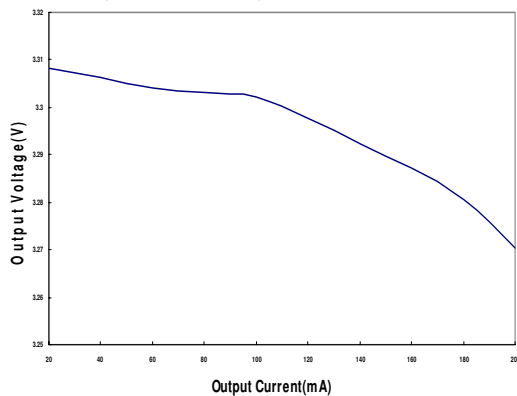

Output Voltage vs. Input Voltage
VIN=4.5V~20V , VOUT=3.3V

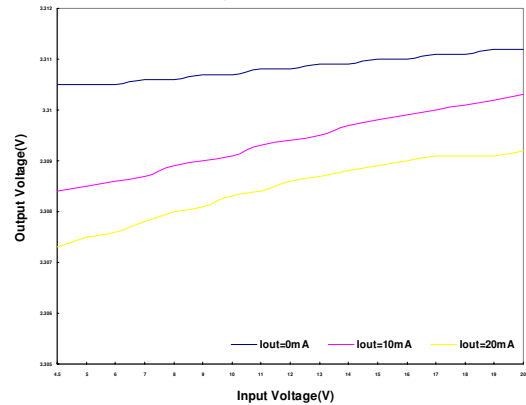

Dropout Voltage vs. Temperature
VIN=4.5V , VOUT=3.3V

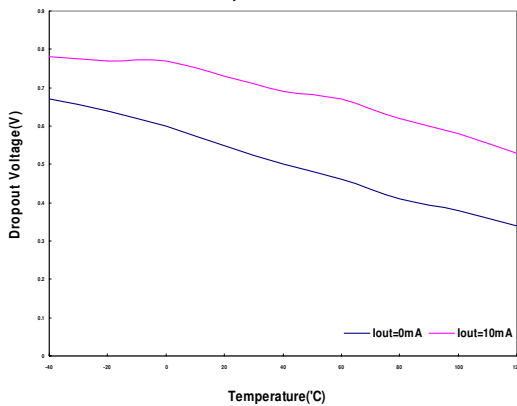

Dropout Voltage vs. Output Current
VIN=4.5V , VOUT=3.3V , IOU=10mA~200mA

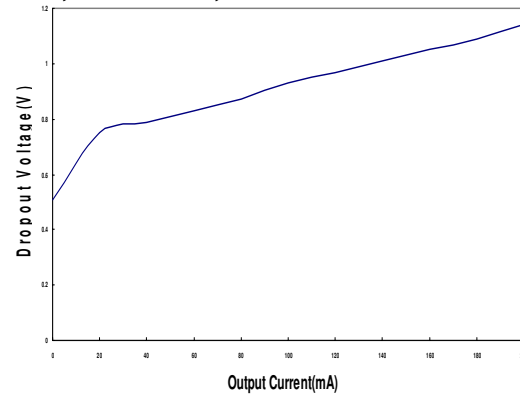



MARKING INFORMATION

ESOP-8

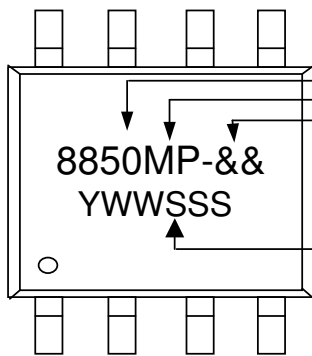

Part Number
Package Code
Output Voltage :
Date Code (YWWSSS)
Y : Last Digit Of The Year
WW : Week
SSS : Sequence

Identification Code	V _{OUT}	Identification Code	V _{OUT}
Blank	ADJ	28	2.8V
15	1.5V	30	3.0V
18	1.8V	33	3.3V
25	2.5V	50	5.0V

SOT-23-5L / TSOT-23-5L

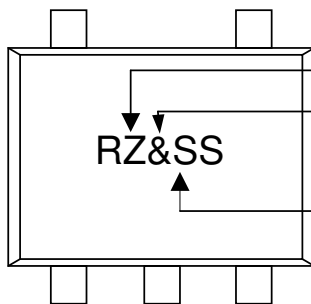

Part Number : RZ
Output Voltage :
Date Code
SS:2004,2008,2012...
SS:2003,2007,2011...
SS:2002,2006,2010...
SS:2001,2005,2009...

Identification Code	V _{OUT}	Identification Code	V _{OUT}
Blank	ADJ	G	2.8V
C	1.5V	H	3.0V
D	1.8V	I	3.3V
F	2.5V	J	5.0V

J-lead 2021-8

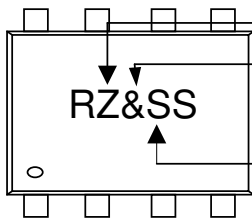

Part Number : RZ
Output Voltage :
Date Code
SS:2004,2008,2012...
SS:2003,2007,2011...
SS:2002,2006,2010...
SS:2001,2005,2009...

Identification Code	V _{OUT}	Identification Code	V _{OUT}
Blank	ADJ	G	2.8V
C	1.5V	H	3.0V
D	1.8V	I	3.3V
F	2.5V	J	5.0V

SOT-89

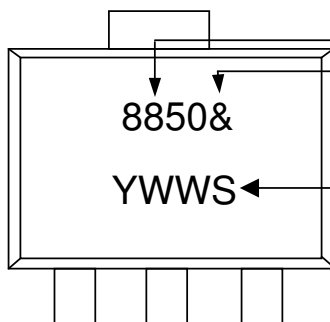

Part Number
Output Voltage :
Date Code (YWWS)
Y:Year
WW : Week
S : Sequence

Identification Code	V _{OUT}	Identification Code	V _{OUT}
Blank	ADJ	G	2.8V
C	1.5V	H	3.0V
D	1.8V	I	3.3V
F	2.5V	J	5.0V