



## 600mA LOW DROPOUT LINEAR REGULATOR

### FEATURES

- Low Dropout Voltage of 600mV at 600mA
- Guaranteed 600mA Output Current
- Very Low Quiescent Current at about 30uA
- Max.  $\pm 2\%$  Output Accuracy
- Needs Only 1 $\mu$ F Capacitor for Stability
- Thermal Shutdown Protection
- Current Limit Protection
- Low-ESR Ceramic Capacitor for Output Stability
- RoHS Compliant

### APPLICATIONS

- DVD/CD-ROMs, CD/RWs
- Wireless Devices
- LCD Modules
- Battery Power Systems
- Card Readers
- XDSL Routers

### DESCRIPTION

The APE8805 series are low dropout, positive linear regulators with very low quiescent current. The APE8805 can supply 600mA output current with a low dropout voltage at about 600mV.

The APE8805 regulator is able to operate with output capacitors as small as 1 $\mu$ F for stability. Other than the current limit protection APE8805 also offers on chip thermal shutdown feature providing protection against overload or any condition when the ambient temperature exceeds the junction temperature.

The APE8805 series are available in fixed output voltage ranging from 1.5V, 1.8V, 2.0V, 2.5V, 2.8V, 3V and 3.3V. The APE8805 series are available in space-saving SOT-23, SOT-89, and SOT-223 packages.

### TYPICAL APPLICATION CIRCUIT

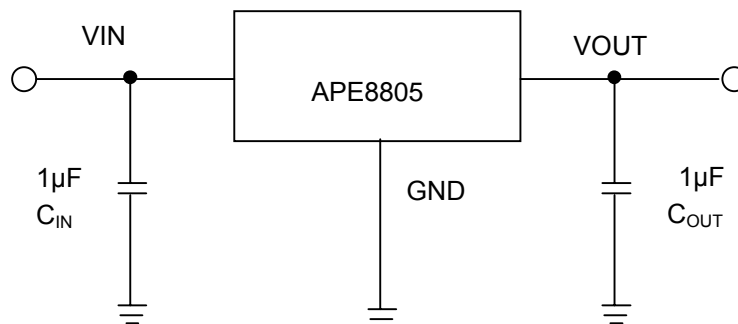
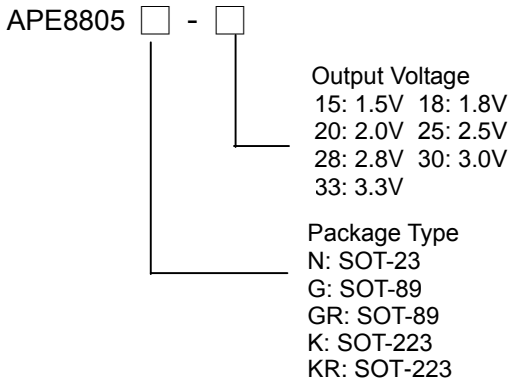

Figure 1. Typical Application Circuit of APE8805

Note : To prevent oscillation, it is recommended to use minimum 1 $\mu$ F X7R or X5R dielectric capacitors if ceramics are used as input/output capacitors.



**ORDERING INFORMATION**



Note : The devices are available in fixed voltages range of 1.5V, 1.8V, 2.0V, 2.5V, 2.8V, 3V & 3.3V. Please consult APEC sales office or authorized distributor for availability of special output voltages.

**PIN ASSIGNMENTS**

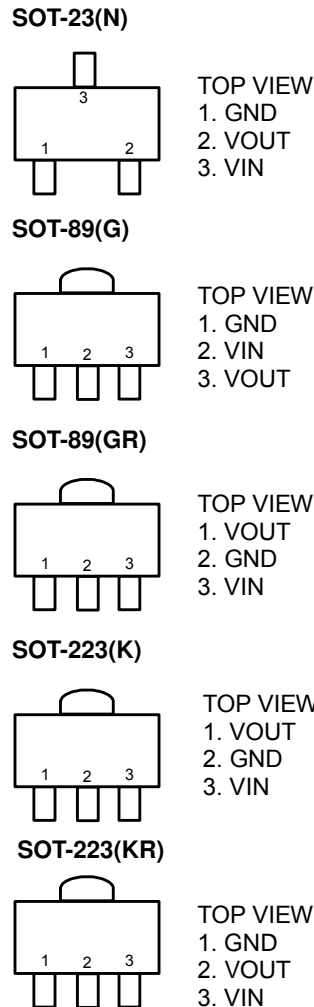

Figure 2. Pin Assignment of APE8805

**ABSOLUTE MAXIMUM RATINGS**

Parameter	Symbol	Min	Max	Unit
Supply Input Voltage	$V_{IN}$		6	V
Maximum Junction Temperature	$T_J$		150	°C
Power Dissipation SOT-23	$P_D$		0.4	W
Power Dissipation SOT-89	$P_D$		0.57	W
Power Dissipation SOT-223	$P_D$		0.74	W
Package Thermal Resistance SOT-23	$\theta_{JA}$		250	°C/W
Package Thermal Resistance SOT-89	$\theta_{JA}$		175	°C/W
Package Thermal Resistance SOT-223	$\theta_{JA}$		135	°C/W
Storage Temperature Range	$T_S$	-65	150	°C
Lead Temperature (Soldering, 10 sec.)	$T_{LEAD}$		260	°C

Note : Stresses beyond those listed under "Absolute Maximum Ratings" may cause permanent damage to the device.



## RECOMMENDED OPERATING CONDITIONS

Parameter	Symbol	Min	Max	Unit
Input Voltage	$V_{IN}$	2.8	5.5	V
Operating Junction Temperature Range	$T_J$	-40	125	°C
Ambient Temperature Range	$T_A$	-40	125	°C

## ELECTRICAL CHARACTERISTICS

( $V_{IN}=V_{OUT}+1V$  or  $V_{IN}=2.8V$  whichever is greater,  $C_{IN}=1\mu F$ ,  $C_{OUT}=1\mu F$ ,  $T_A=25\text{ }^\circ\text{C}$ , unless otherwise specified)

Parameter	Symbol	Conditions	Min	Typ	Max	Unit
Output Voltage Accuracy	$\Delta V_{OUT}$	$I_O = 1\text{mA}$	-2		+2	%
Current Limit	$I_{LIMIT}$	$R_{Load}=1\Omega$	600			mA
Quiescent Current	$I_Q$	$I_O = 0\text{mA}$		30	50	$\mu\text{A}$
Dropout Voltage (Note 1)	$V_{DROP}$	$1.2V \leq V_{OUT} \leq 2.0V$		1400		mV
		$2.0V < V_{OUT} \leq 2.8V$		800		
		$2.8V < V_{OUT} \leq 4.5V$		600		
Line Regulation	$\Delta V_{LINE}$	$I_O=1\text{mA}$ , $V_{IN}=V_{OUT}+1V$ to 5V		1	5	mV
Load Regulation (Note 2)	$\Delta V_{LOAD}$	$I_O=0\text{mA}$ to 600mA		13	50	mV
Ripple Rejection	PSRR	$V_{IN}=V_{OUT}+1V$ $f_{RIPPLE} = 120\text{Hz}$ , $C_{OUT} = 1\mu F$		60		dB
Temperature Coefficient	TC	$I_{OUT} = 1\text{mA}$ , $V_{IN} = 5V$		50		ppm/°C
Thermal Shutdown Temperature	TSD			160		°C
Thermal Shutdown Hysteresis	$\Delta TSD$			25		°C

Note 1 : The dropout voltage is defined as  $V_{IN}-V_{OUT}$ , which is measured when  $V_{OUT}$  drop about 100mV.

Note 2 : Regulation is measured at a constant junction temperature by using 40ms current pulse and load regulation in the load range from 0mA to 600mA.

## FUNCTIONAL PIN DESCRIPTION

Pin Name	Pin Function
<b>VIN</b>	Power is supplied to this device from this pin which is required an input filter capacitor. In general, the input capacitor in the range of 1 $\mu\text{F}$ to 10 $\mu\text{F}$ is sufficient.
<b>VOUT</b>	The output supplies power to loads. The output capacitor is required to prevent output voltage unstable. The APE8805 is stable with an output capacitor 1 $\mu\text{F}$ or greater. The larger output capacitor will be required for application with large transit load to limit peak voltage transits, besides could reduce output noise, improve stability, PSRR.
<b>GND</b>	Common ground pin



## BLOCK DIAGRAM

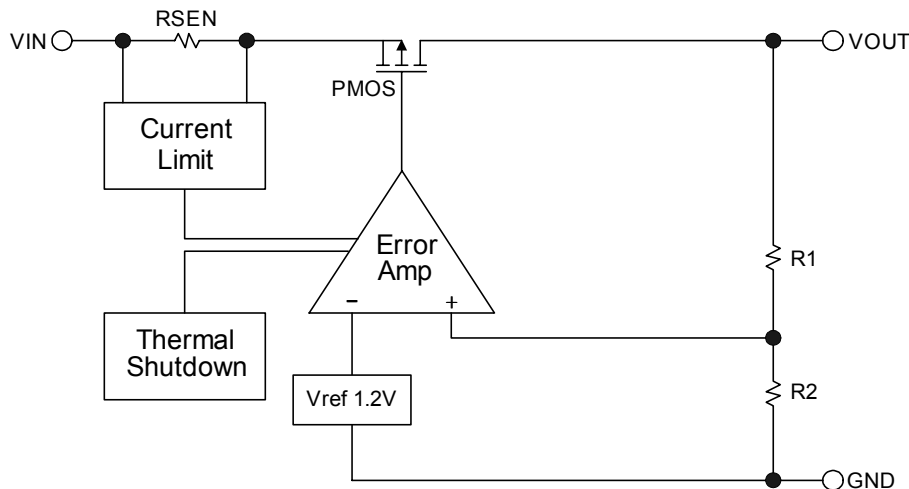

Figure 3. Block Diagram of APE8805

## APPLICATION INFORMATION

The APE8805 series are low dropout linear regulators that could provide 600mA output current at dropout voltage about 600mV. Besides, current limit and on chip thermal shutdown features provide protection against any combination of overload or ambient temperature that could exceed junction temperature.

### 1. OUTPUT AND INPUT CAPACITOR

The APE8805 regulator is designed to be stable with a wide range of output capacitors. The ESR of the output capacitor affects stability. Larger value of the output capacitor decreases the peak deviations and provides to improve transition response for larger current changes. The capacitor types (aluminum, ceramic, and tantalum) have different characterizations such as temperature and voltage coefficients. All ceramic capacitors are manufactured with a variety of dielectrics, each with different behavior across temperature and applications. Common dielectrics used are X5R, X7R and Y5V. It is recommended to use 1uF to 10uF X5R or X7R dielectric ceramic capacitors with 30mΩ to 50mΩ ESR range between device outputs to ground for transient stability. The APE8805 is designed to be stable with low ESR ceramic capacitors and higher values of capacitors and ESR could improve output stability. So the

ESR of output capacitor is very important because it generates a zero to provide phase lead for loop stability. There are no requirements for the ESR on the input capacitor, but its voltage and temperature coefficient have to be considered for device application environment.

### 2. PROTECTION FEATURES

In order to prevent overloading or thermal condition from damaging device, APE8805 regulator has internal thermal and current limiting functions designed to protect the device. It will rapidly shut off PMOS pass element during overloading or over temperature condition.

### 3. THERMAL CONSIDERATION

The power handling capability of the device will be limited by maximum operation junction temperature (125°C). The power dissipated by the device will be estimated by

$$PD = I_{OUT} \times (V_{IN} - V_{OUT}).$$

The power dissipation should be lower than the maximum power dissipation listed in "Absolute Maximum Ratings" section.



## TYPICAL PERFORMANCE CURVES

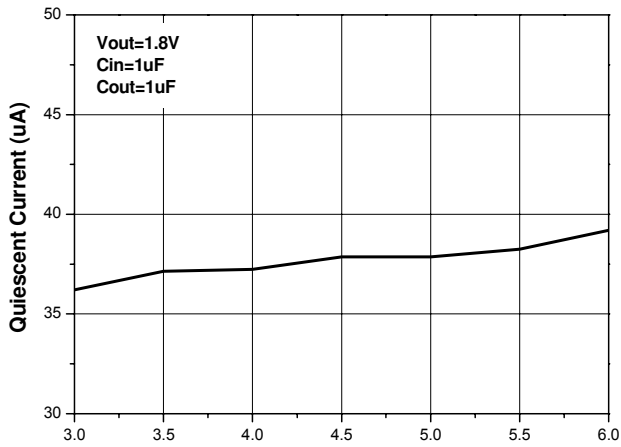

Figure 4. Quiescent Current vs. Input Voltage

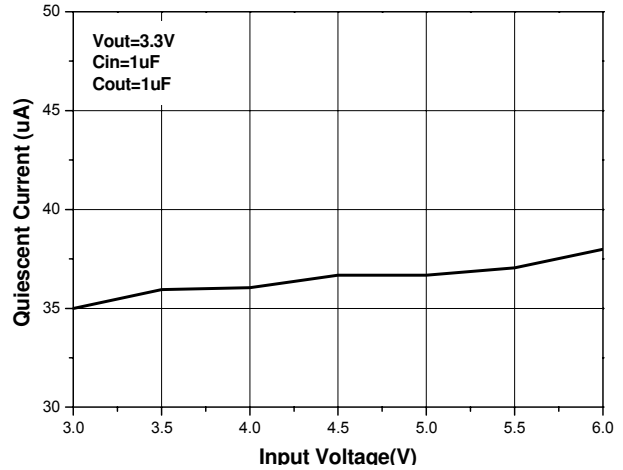

Figure 5. Quiescent Current vs. Input Voltage

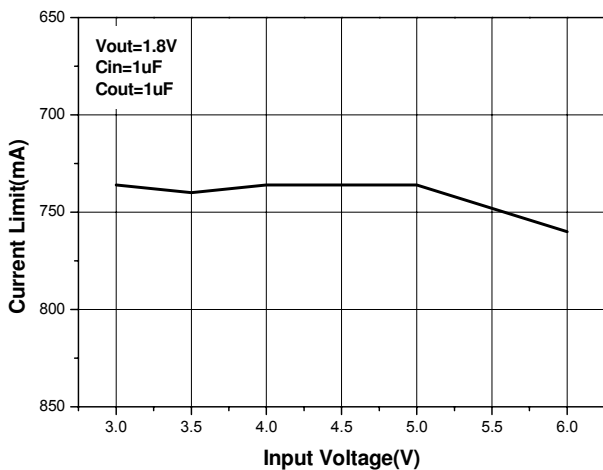

Figure 6. Current limit vs. Input Voltage

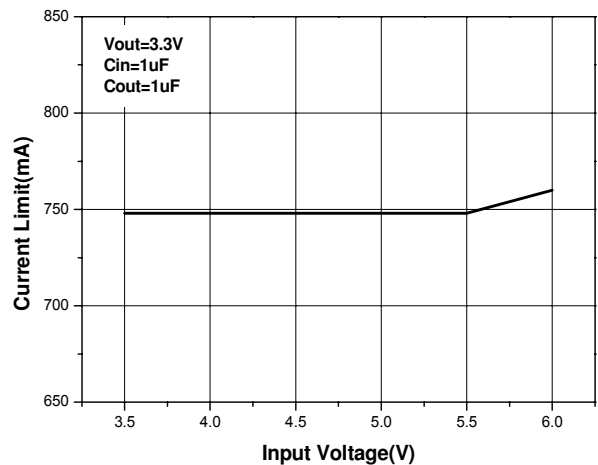

Figure 7. Current Limit vs. Input Voltage

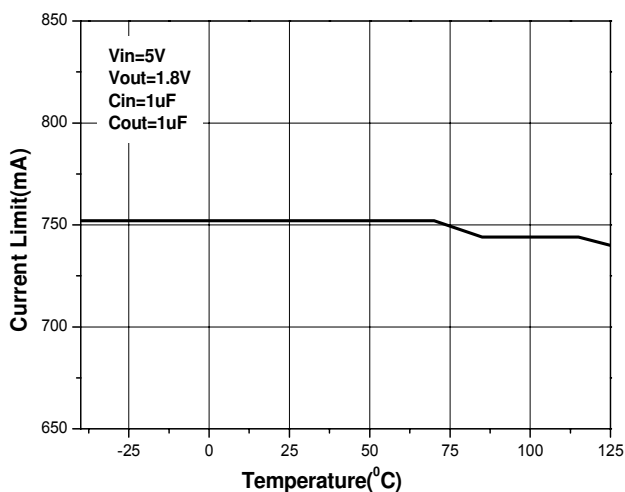

Figure 8. Current limit vs. Temperature

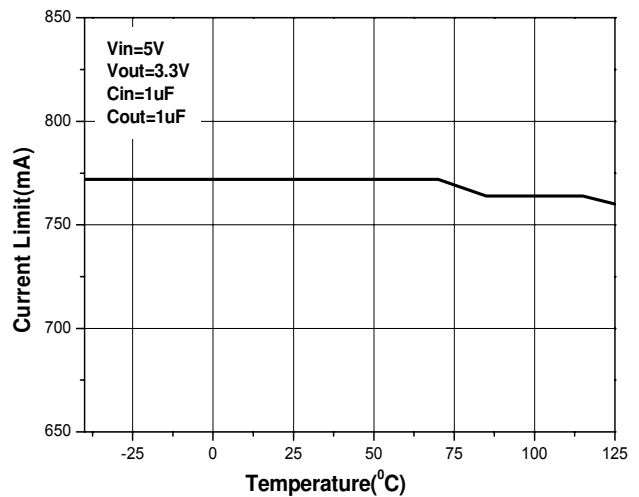

Figure 9. Current limit vs. Temperature



## TYPICAL PERFORMANCE CURVES (Continued)

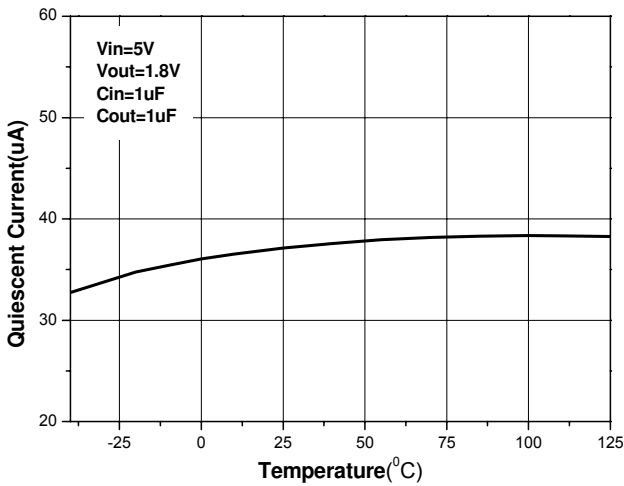

Figure 10. Quiescent Current vs. Temperature

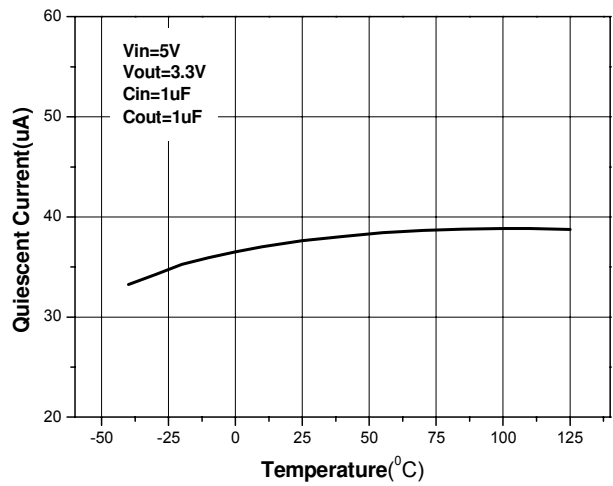

Figure 11. Quiescent Current vs. Temperature

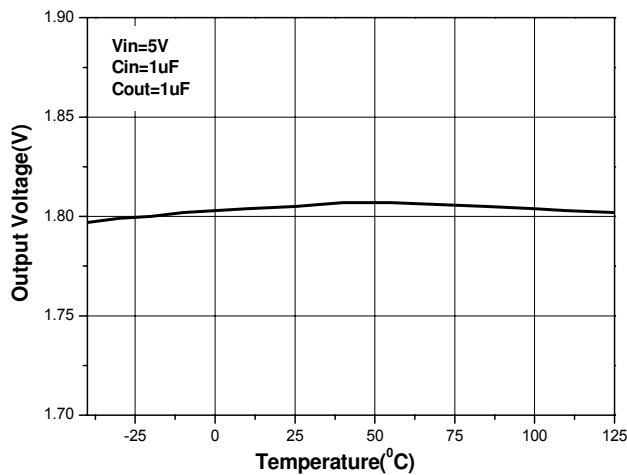

Figure 12. Temperature Stability

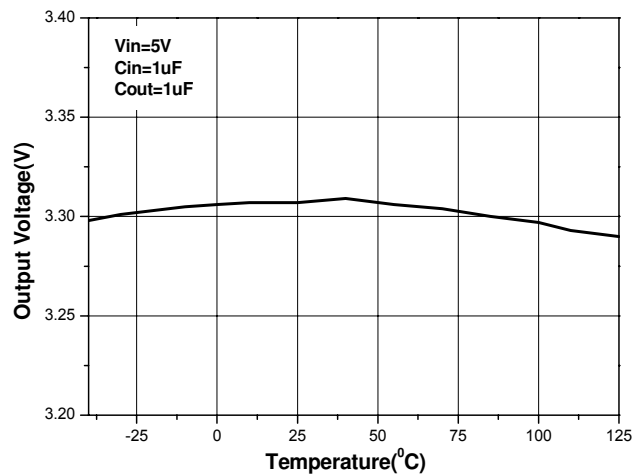

Figure 13. Temperature Stability

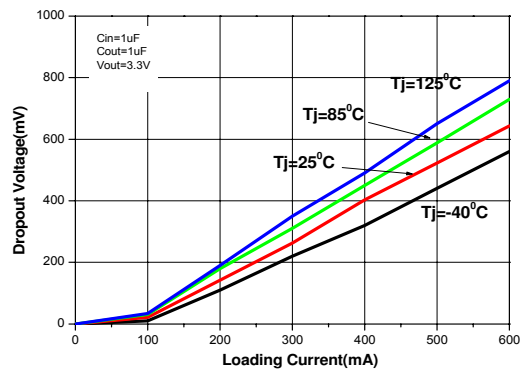

Figure 14. Dropout Voltage vs. Loading Current



## TYPICAL PERFORMANCE CURVES (Continued)

$V_{IN}=4V$   $I_{OUT}=1mA$  to  $150mA$   
 $V_{OUT}=3.3V$   $C_{IN}=1\mu F$   $C_{OUT}=1\mu F$

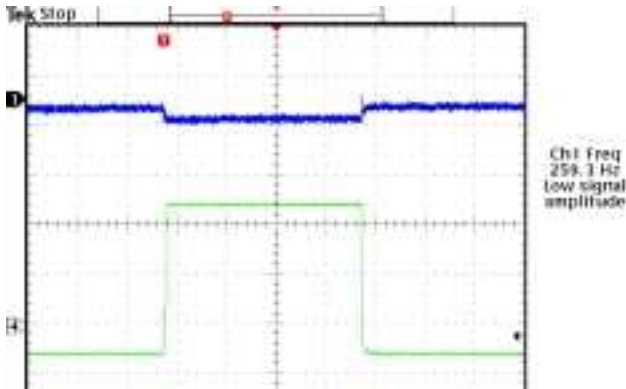

Figure 15. Load Transition Response

$V_{IN}=4V$   $I_{OUT}=1mA$  to  $150mA$   
 $V_{OUT}=3.3V$   $C_{IN}=1\mu F$   $C_{OUT}=4.7\mu F$

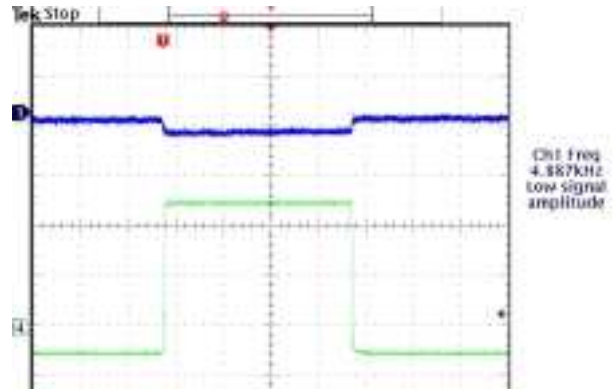

Figure 16. Load Transition Response

$V_{IN}=3V$  to  $4V$   $I_{OUT}=10mA$   $V_{OUT}=1.8V$   $C_{IN}=1\mu F$   $C_{OUT}=1\mu F$

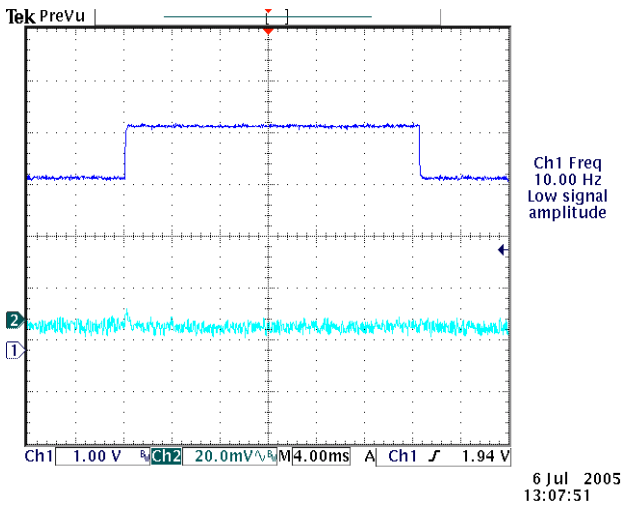

Figure 17. Line Transition Response

$V_{IN}=3V$  to  $4V$   $I_{OUT}=10mA$   $V_{OUT}=1.8V$   $C_{IN}=1\mu F$   $C_{OUT}=4.7\mu F$

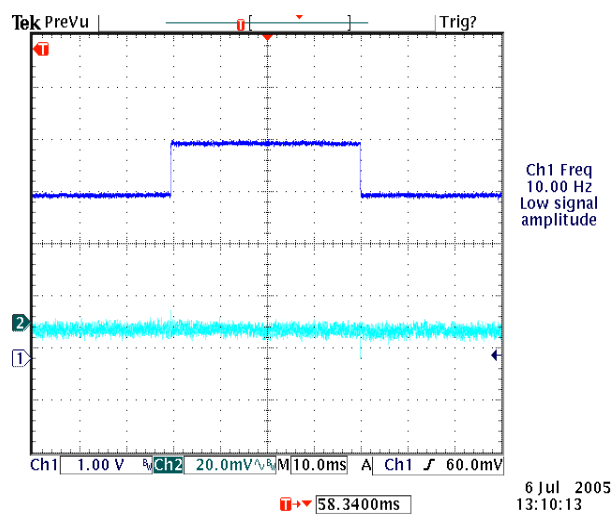
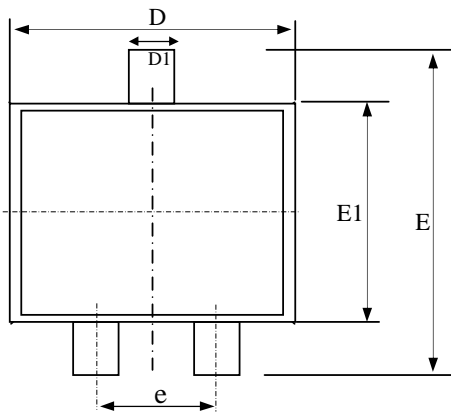

Figure 18. Line Transition Response



**Package Outline : SOT-23**



SYMBOLS	Millimeters		
	MIN	NOM	MAX
A	1.00	1.15	1.30
A1	0.00	--	0.10
A2	0.10	0.15	0.25
D1	0.30	0.40	0.50
e	1.70	2.00	2.30
D	2.70	2.90	3.10
E	2.40	2.65	3.00
E1	1.40	1.50	1.60

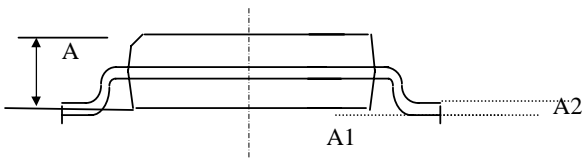

1. All Dimension Are In Millimeters.
2. Dimension Does Not Include Mold Protrusions.

**Part Marking Information & Packing : SOT-23**

Laser Marking

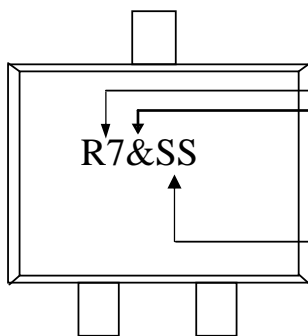

Part Number : R7  
 Output Voltage : ADJ : Blank  
 A : 1.5V    D : 2.8V    P : 2.0V  
 B : 1.8V    E : 3.0V  
 C : 2.5V    F : 3.3V  
 Date Code :  
 SS:2004,2008,2012...  
 SS:2003,2007,2011...  
 SS:2002,2006,2010...  
 SS:2001,2005,2009...  
 "A~Z" showed on 3rd position --> week 1 ~ week 26,  
 "A~Z" showed on 4th position --> week 27 ~ week 52.



**Package Outline & Packing : SOT-89**

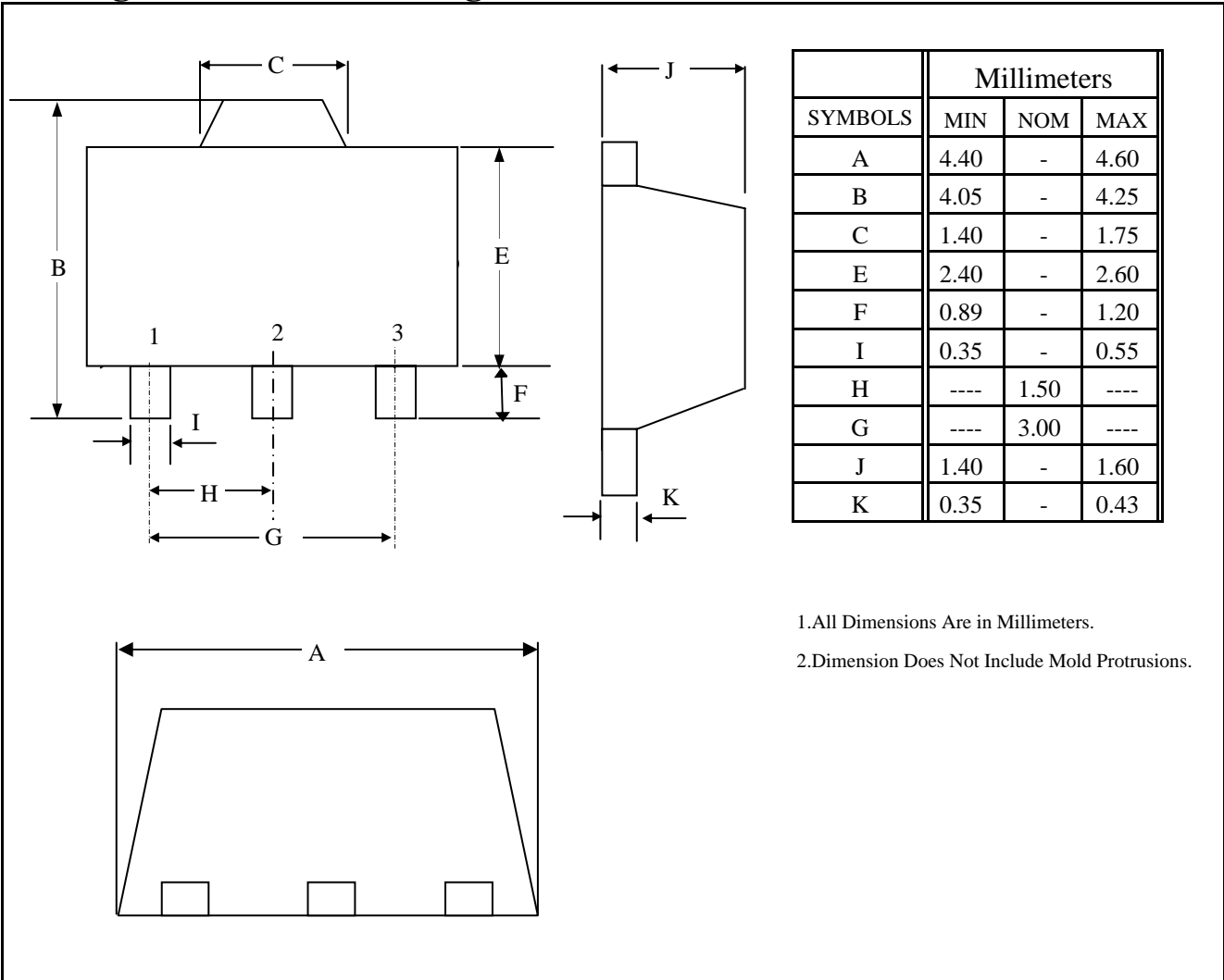

**Part Marking Information : SOT-89**

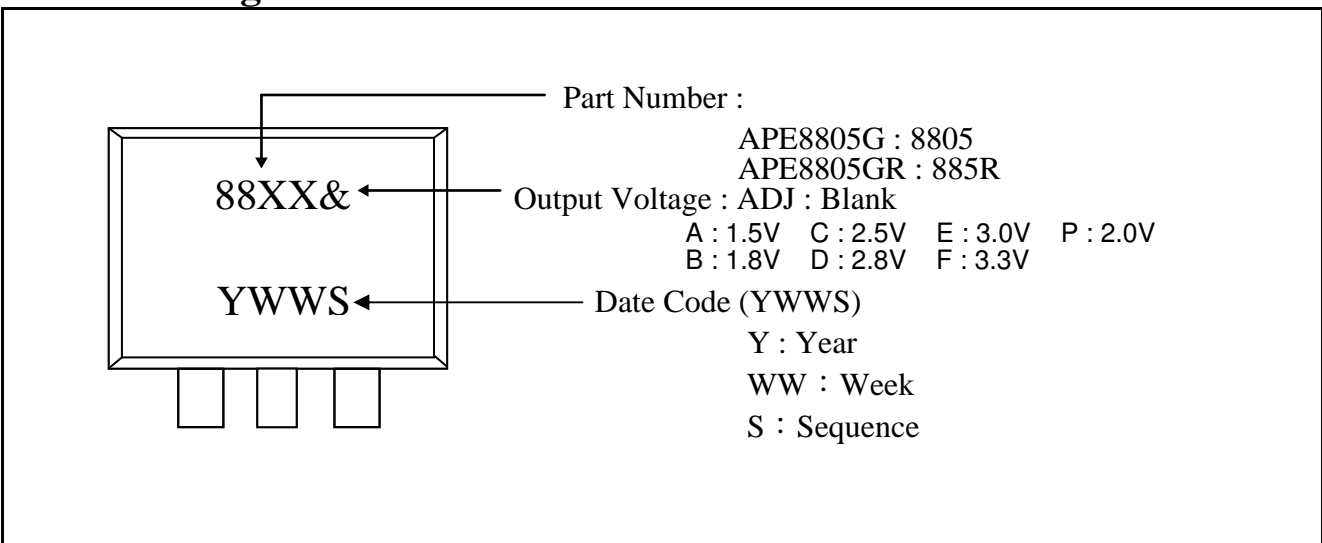



**Package Outline : SOT-223**

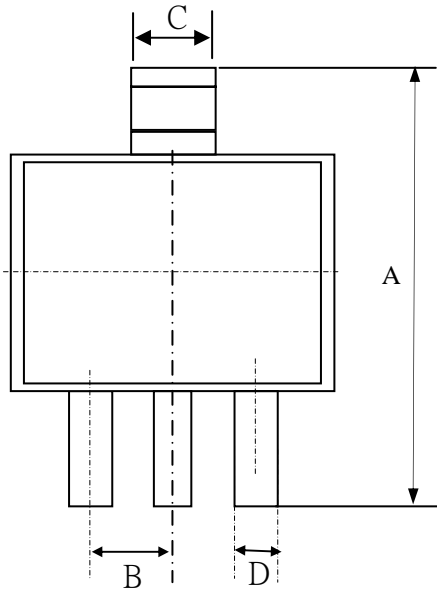

SYMBOLS	Millimeters		
	MIN	NOM	MAX
A	6.70	7.00	7.30
B	---	2.3	---
C	2.90	3.00	3.10
D	0.60	0.70	0.80
G	0.25	0.30	0.35
E	6.30	6.50	6.70
F	1.40	1.60	1.80
K	0.02	0.06	0.10

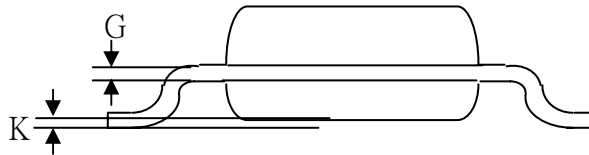
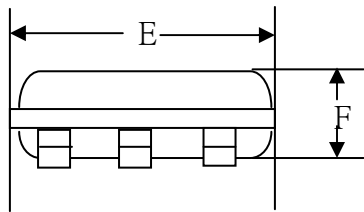

- 1.All Dimension Are In Millimeters.
- 2.Dimension Does Not Include Mold Protrusions.

**Part Marking Information & Packing : SOT-223**

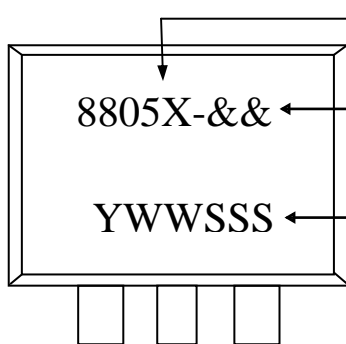

Part Number :

APE8805K : 8805  
 APE8805KR : 8805R

Output Voltage : ADJ : Blank

15 : 1.5V 25 : 2.5V 30 : 3.0V 20 : 2.0V  
 18 : 1.8V 28 : 2.8V 33 : 3.3V

Date Code (YWWSSS)

Y : Last Digit Of The Year

WW : Week

SSS : Sequence