



## 300mA ULTRA LOW DROPOUT REGULATORS

### FEATURES

- 5-PIN SOT-23 Package
- Stable with 2.2μF Ceramic Capacitor
- 2% Voltage Reference Accuracy
- Only 270mV Dropout at 300mA and 170mV Dropout at 150mA
- 5μA Quiescent Current in Shutdown
- Current Limit and Thermal Shutdown
- Logic Input Enable Pin
- RoHS Compliant

### APPLICATIONS

- Laptop, Notebook & Palmtop computers
- Battery Powered Equipments
- PCMCIA Vcc & Vpp Regulator
- Consumer Electronics
- High Efficiency Linear Power Supplies

### DESCRIPTION

The APU8831 device is an efficient linear voltage regulator with better than 2% initial voltage accuracy, very low dropout voltage and very low ground current designed especially for hand held, battery powered applications. Other features of the device are: TTL compatible enable/shutdown control input, current limiting and thermal shutdown.

The APU8831 is available in fixed and adjustable output voltage versions in a small SOT-23 5-Pin package.

### TYPICAL APPLICATION

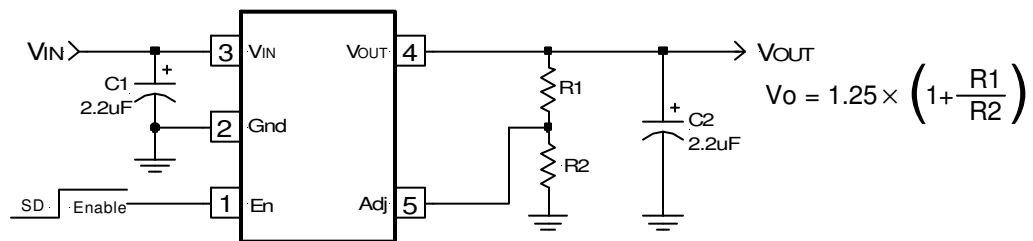

Figure 1 - Typical application of the APU8831 adjustable voltage regulator.

### PACKAGE ORDER INFORMATION

T <sub>J</sub> (°C)	5-PIN SOT-23	OUTPUT VOLTAGE
0 To 125	APU8831Y5	Adj



### ABSOLUTE MAXIMUM RATINGS

Input Voltage ( $V_{IN}$ )	10V
Enable Input Voltage	10V
Storage Temperature Range	-65°C To 150°C
Operating Junction Temperature Range	0°C To 150°C

### PACKAGE INFORMATION

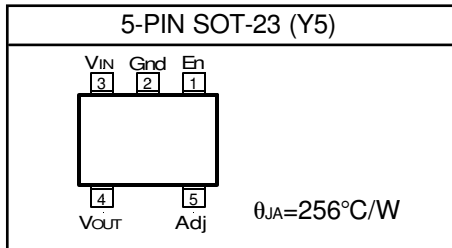

### ELECTRICAL SPECIFICATIONS

Unless otherwise specified, these specifications apply over  $C_{IN}=C_O=22\mu F$ ,  $I_O=100\mu A$ ,  $V_{IN(MIN)}=2.5V$ (Adjustable devices)  $V_{IN}=V_O + 1V$ (for fixed voltage devices),  $V_{OUT}=V_{FB}$ (for adjustable version only),  $C_{BYP}=470pF$ (for fixed voltage devices),  $V_{ENB}=2V$  and  $T_A=25^\circ C$ . Typical values refer to  $T_A=25^\circ C$ . Low duty cycle pulse testing is used which keeps junction and case temperatures equal to the ambient temperature.

PARAMETER	SYM	TEST CONDITION	MIN	TYP	MAX	UNITS
Reference Voltage (See Table 1 for typical values)	$V_O$		-2		2	%
Line Regulation	$\Delta V_I$	$V_O + 1V < V_{IN} < 10V$		0.005		%/V
Load Regulation (Note 1)	$\Delta V_L$	$1mA < I_O < 100mA$ $100mA < I_O < 300mA$		0.8 0.1		%
Dropout Voltage (Note 2)	$\Delta V_{I(O)}$	$I_O=100\mu A$ $I_O=100\mu A$ (Note 4) $I_O=50mA$ $I_O=50mA$ (Note 4) $I_O=150mA$ $I_O=150mA$ (Note 4) $I_O=300mA$ $I_O=300mA$ (Note 4)		10 13 85 100 170 204 270 324	50 70 110 140 220 260 350 400	mV
Ground Current (Note 3)	$I_Q$	$V_{EN}=2V$ , $I_O=100\mu A$ $I_O=100\mu A$ (Note 4) $I_O=50mA$ $I_O=50mA$ (Note 4) $I_O=150mA$ $I_O=150mA$ (Note 4) $I_O=300mA$ $I_O=300mA$ (Note 4)		120 240 420 540 2200 2900 7200 9300	160 600 2900 9500	$\mu A$
Ground Current-SD Activated	$I_{Q(SD)}$	$V_{EN}=0V$ to 0.8V or Open		5		$\mu A$
Current Limit	$I_{CL}$	$V_O=0V$	320	420		mA
Thermal Regulation	$\Delta V_P$	$V_{IN}=10V$ , $I_O=150mA$ , 10ms Pulse		0.05		%/W
Adjust Pin Current	$I_{ADJ}$	$V_{IN}=2.5V$ , $V_O=V_{ADJ}$		0.1		$\mu A$
Enable Pin Input LO Voltage	$V_{EN(L)}$	Regulator OFF			0.8	V
Enable Pin Input HI Voltage	$V_{EN(H)}$	Regulator ON	2			V
Enable Pin Input LO Current		$V_{EN(L)}=0V$ to 0.8V		0.01		$\mu A$
Enable Pin Input HI Current		$V_{EN(H)}=2V$ to $V_{IN}$		20		$\mu A$



**Note 1:** Low duty cycle pulse testing with Kelvin connections is required in order to maintain accurate data.

**Note 2:** Dropout voltage is defined as the minimum differential voltage between  $V_{IN}$  and  $V_{OUT}$  required to maintain regulation at  $V_{OUT}$ . It is measured when the output voltage drops 1% below its nominal value.

**Note 3:** Ground current is the regulator quiescent current plus the pass transistor current. The total current from the supply is the sum of the load current plus the ground pin current.

## PIN DESCRIPTIONS

PIN #	PIN SYMBOL	PIN DESCRIPTION
3	$V_{IN}$	The input pin of the regulator. Typically a large storage capacitor is connected from this pin to ground to insure that the input voltage does not sag below the minimum drop out voltage during the load transient response. This pin must always be higher than $V_{OUT}$ by at least the amount of the dropout voltage and some margin in order for the device to regulate properly.
2	Gnd	Ground pin. This pin must be connected to the lowest potential in the system and all other pins must be at higher potential with respect to this pin.
1	En	Enable pin. A low signal or left open on this pin shuts down the output. This pin must be tied HI or to $V_{IN}$ for normal operation.
5	Adj	A resistor divider from this pin to the $V_{OUT}$ pin and ground sets the output voltage. To minimize the error due to the error amplifier, select the values of the resistor dividers to be less than 10K $\Omega$ .
4	$V_{OUT}$	The output of the regulator. A minimum of 2.2 $\mu$ F with max ESR of 1 $\Omega$ capacitor must be connected from this pin to ground to insure stability.

5-PIN SOT-23	Output Voltage
APU8831	1.25V

Table 1- Nominal output voltage vs. part number.

The output voltage of the adjustable device can be set using:

$$V_o = 1.25 \times \left( 1 + \frac{R_1}{R_2} \right)$$

Where:

R1 = Resistor connected from output to the Adj pin

R2 = Resistor connected from Adj pin to Gnd



**BLOCK DIAGRAM**

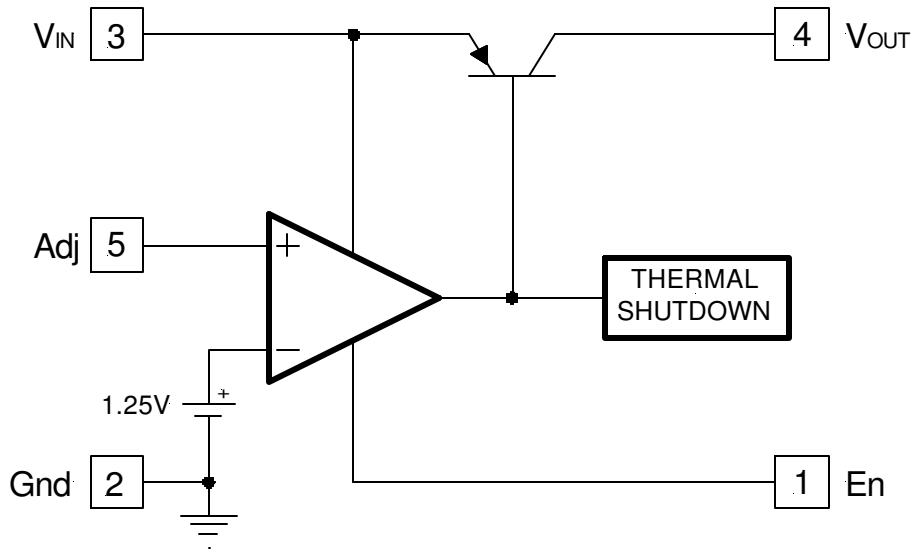
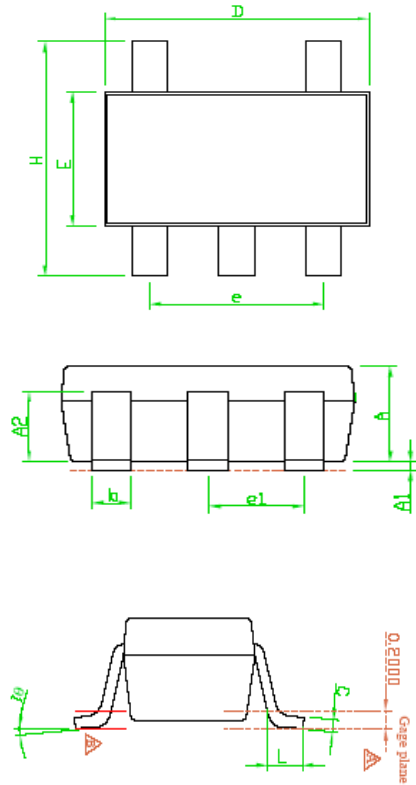

Figure 2 - APU8831 Adjustable output block diagram.



### Package Outline : SOT-23-5L



SYMBOLS	Millimeters		
	MIN	NOM	MAX
A	1.00	1.10	1.30
A1	0.00	---	0.10
A2	0.70	0.80	0.90
b	0.35	0.40	0.50
C	0.10	0.15	0.25
D	2.70	2.90	3.10
E	1.50	1.60	1.80
e	---	1.90(TYP)	---
H	2.60	2.80	3.00
L	0.37	---	---
$\theta 1$	1°	5°	9°
e2	---	0.95(TYP)	---

- Note 1 : Package Body Sizes Exclude Mold Flash Protrusions or Gate Burrs.
- Note 2 : Tolerance  $\pm 0.1000$  mm(4mil) Unless Otherwise Specified.
- Note 3 : Coplanarity : 0.1000 mm
- Note 4 : Dimension L Is Measured in Gage plane.

### Part Marking Information & Packing : SOT-23 -5L

