



6A ULTRA LOW DROPOUT POSITIVE ADJUSTABLE REGULATOR

FEATURES

- 0.62V Dropout at 6A
- Fast Transient Response
- 1% Voltage Reference Initial Accuracy
- Built-In Thermal Shutdown
- RoHS Compliant

APPLICATIONS

- VGA Card Applications
- On-Board Low Voltage Regulator Supply such as 3.3V to 2.8V

DESCRIPTION

The APU1160 is a 6A regulator with extremely low dropout voltage using a proprietary bipolar process that achieves comparable equivalent on resistance to that of discrete MOSFETs. This product is specifically designed to provide well regulated supply for applications requiring 2.8V or lower voltages from 3.3V ATX power supplies where high efficiency of a switcher can be achieved without the cost and complexity associated with switching regulators.

TYPICAL APPLICATION

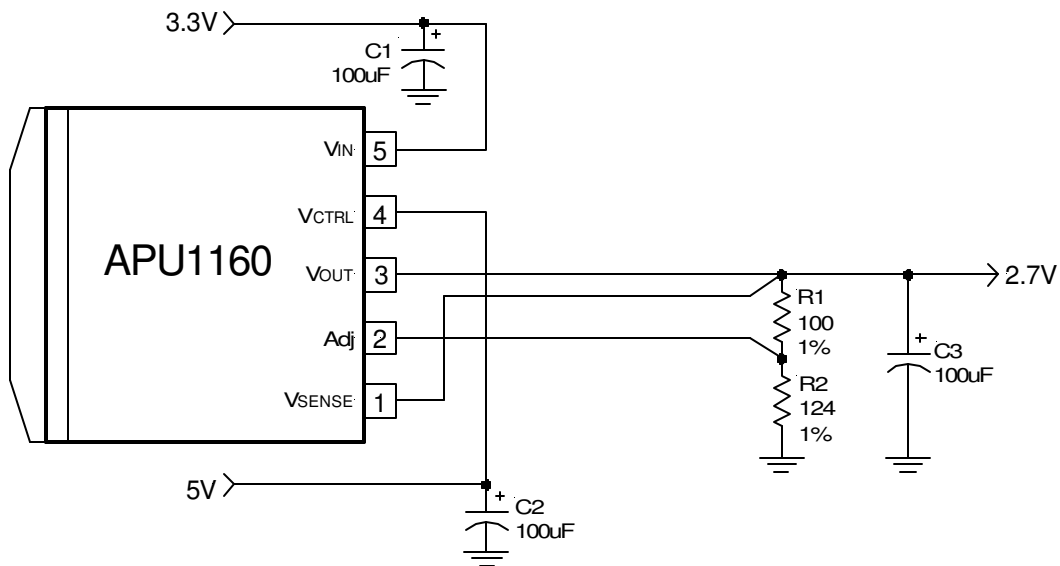

Figure 1 - Typical application of APU1160 in a 3.3V to 2.8V.

PACKAGE ORDER INFORMATION

T _J (°C)	5-PIN PLASTIC TO-263 (S)
0 To 125	APU1160S



ABSOLUTE MAXIMUM RATINGS

Input Voltage (V_{IN})	7V
Control Input Voltage (V_{CTRL})	14V
Power Dissipation	Internally Limited
Storage Temperature Range	-65°C To 150°C
Operating Junction Temperature Range	0°C To 150°C

PACKAGE INFORMATION

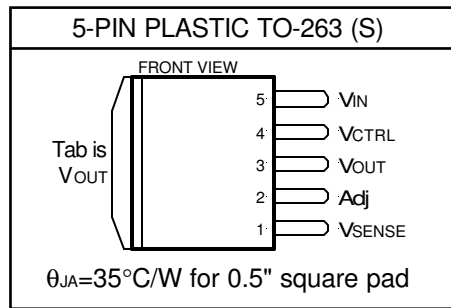

ELECTRICAL SPECIFICATIONS

Unless otherwise specified, these specifications apply over $C_{IN}=\mu\text{F}$, $C_{OUT}=10\mu\text{F}$, and $T_J=0$ to 125°C . Typical values refer to $T_J=25^{\circ}\text{C}$. $V_{OUT}=V_{SENSE}$.

PARAMETER	SYM	TEST CONDITION	MIN	TYP	MAX	UNITS
Reference Voltage	V_{REF}	$V_{CTRL}=2.75$, $V_{IN}=2\text{V}$, $I_o=10\text{mA}$, $T_J=25^{\circ}\text{C}$, $V_{ADJ}=0\text{V}$ $V_{CTRL}=2.7$ to 12V , $V_{IN}=2.05\text{V}$ to 5.5V , $I_o=10\text{mA}$ to 6A , $V_{ADJ}=0\text{V}$	1.225	1.250	1.275	V
Line Regulation		$V_{CTRL}=2.5\text{V}$ to 7V , $V_{IN}=1.75\text{V}$ to 5.5V , $I_o=10\text{mA}$, $V_{ADJ}=0\text{V}$			3	mV
Load Regulation (Note 1)		$V_{CTRL}=2.75\text{V}$, $V_{IN}=2.1\text{V}$, $I_o=10\text{mA}$ to 6A , $V_{ADJ}=0\text{V}$			6	mV
Dropout Voltage (Note 2) ($V_{CTRL} - V_{OUT}$)		$V_{ADJ}=0\text{V}$ for all conditions below: $V_{IN}=2.05\text{V}$, $I_o=1.5\text{A}$ $V_{IN}=2.05\text{V}$, $I_o=5\text{A}$ $V_{IN}=2.05\text{V}$, $I_o=6\text{A}$		1.00 1.10 1.20	1.30	V
Dropout Voltage (Note 2) ($V_{IN} - V_{OUT}$)		$V_{ADJ}=0\text{V}$ for all conditions below: $V_{CTRL}=2.75\text{V}$, $I_o=1.5\text{A}$ $V_{CTRL}=2.75\text{V}$, $I_o=5\text{A}$ $V_{CTRL}=2.75\text{V}$, $I_o=6\text{A}$		0.15 0.40 0.55	0.20 0.52 0.62	V
Current Limit		$V_{CTRL}=2.75\text{V}$, $V_{IN}=2.05\text{V}$, $\Delta V_o=100\text{mV}$, $V_{ADJ}=0\text{V}$	6.2			A
Minimum Load Current (Note 3)		$V_{CTRL}=5\text{V}$, $V_{IN}=3.3\text{V}$, $V_{ADJ}=0\text{V}$		5	10	mA
Thermal Regulation		30ms Pulse		0.01	0.02	%/W
Ripple Rejection		$V_{CTRL}=5\text{V}$, $V_{IN}=5\text{V}$, $I_o=5\text{A}$, $V_{ADJ}=0\text{V}$, $T_J=25^{\circ}\text{C}$, $V_{RIPPLE}=1\text{V}_{PP}$ at 120Hz	60	70		dB



PARAMETER	SYM	TEST CONDITION	MIN	TYP	MAX	UNITS
Control Pin Current		$V_{ADJ}=0V$ for all below conditions: $V_{CTRL}=2.75V, V_{IN}=2.05V, I_o=1.5A$ $V_{CTRL}=2.75V, V_{IN}=2.05V, I_o=5A$ $V_{CTRL}=2.75V, V_{IN}=2.05V, I_o=6A$		15 50 60		mA
Adjust Pin Current	I_{ADJ}	$V_{CTRL}=2.75V, V_{IN}=2.05V, V_{ADJ}=0V$		50	120	μA

Note 1: Low duty cycle pulse testing with Kelvin connections are required in order to maintain accurate data.

Note 2: Dropout voltage is defined as the minimum differential between V_{IN} and V_{OUT} required to maintain regulation at V_{OUT} . It is measured when the output voltage drops 1% below its nominal value.

Note 3: Minimum load current is defined as the minimum current required at the output in order for the output voltage to maintain regulation. Typically the resistor dividers are selected such that it automatically maintains this current.

PIN DESCRIPTIONS

PIN #	PIN SYMBOL	PIN DESCRIPTION
1	V_{SENSE}	This pin is the positive side of the reference which allows remote load sensing to achieve excellent load regulation.
2	Adj	A resistor divider from this pin to the V_{OUT} pin and ground sets the output voltage.
3	V_{OUT}	The output of the regulator. A minimum of $10\mu F$ capacitor must be connected from this pin to ground to insure stability.
4	V_{CTRL}	This pin is the supply pin for the internal control circuitry as well as the base drive for the pass transistor. This pin must always be higher than the V_{OUT} pin in order for the device to regulate. (See specifications)
5	V_{IN}	The input pin of the regulator. Typically a large storage capacitor is connected from this pin to ground to insure that the input voltage does not sag below the minimum dropout voltage during the load transient response. This pin must always be higher than V_{OUT} in order for the device to regulate. (See specifications)

BLOCK DIAGRAM

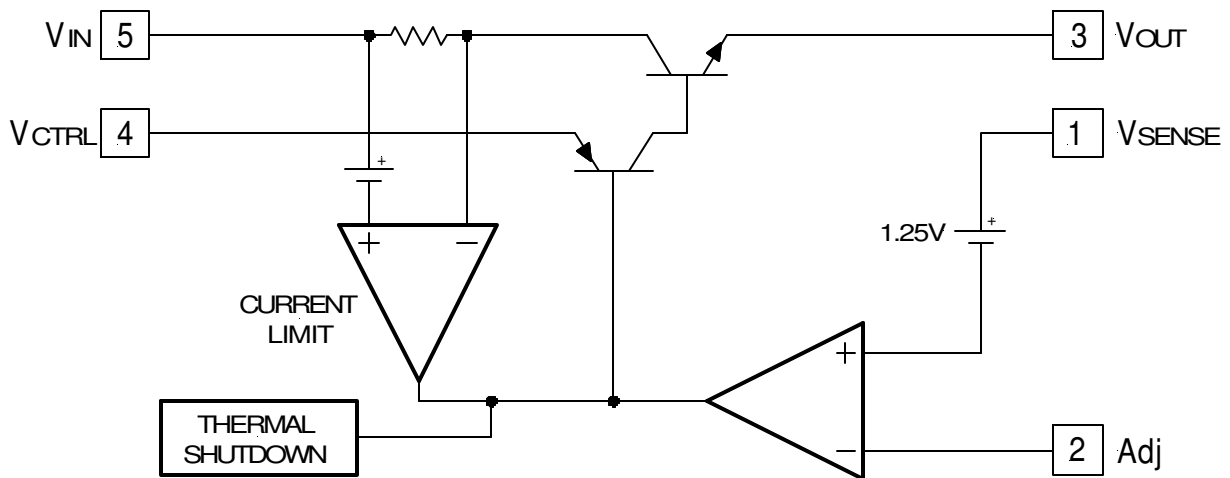

Figure 2 - Simplified block diagram of the APU1160.



APPLICATION INFORMATION

Introduction

The APU1160 adjustable regulator is a five-terminal device designed specifically to provide extremely low drop-out voltages comparable to the PNP type without the disadvantage of the extra power dissipation due to the base current associated with PNP regulators. This is done by bringing out the control pin of the regulator that provides the base current to the power NPN and connecting it to a voltage that is greater than the voltage present at the V_{IN} pin. This flexibility makes the APU1160 ideal for applications where dual inputs are available such as a computer mother board with an ATX style power supply that provides 5V and 3.3V to the board. One such application is the new graphic chip sets that require anywhere from 2.4V to 2.7V supply such as the Intel I740 chip set. The APU1160 can easily be programmed with the addition of two external resistors to any voltages within the range of 1.25 to 5.5 V. Another major requirement of these graphic chips such as the Intel I740 is the need to switch the load current from zero to several amps in tens of nanoseconds at the processor pins, which translates to an approximately 300 to 500ns of current step at the regulator. In addition, the output voltage tolerances are also extremely tight and they include the transient response as part of the specification.

The APU1160 is specifically designed to meet the fast current transient needs as well as providing an accurate initial voltage, reducing the overall system cost with the need for fewer number of output capacitors. Another feature of the device is its true remote sensing capability which allows accurate voltage setting at the load rather than at the device.

Output Voltage Setting

The APU1160 can be programmed to any voltages in the range of 1.25V to 5.5V with the addition of R_1 and R_2 external resistors according to the following formula:

$$V_{OUT} = V_{REF} \times \left(1 + \frac{R_2}{R_1} \right) + I_{ADJ} \times R_2$$

Where:

$V_{REF} = 1.25V$ Typically

$I_{ADJ} = 50\mu A$ Typically

R_1 & R_2 as shown in Figure 3:

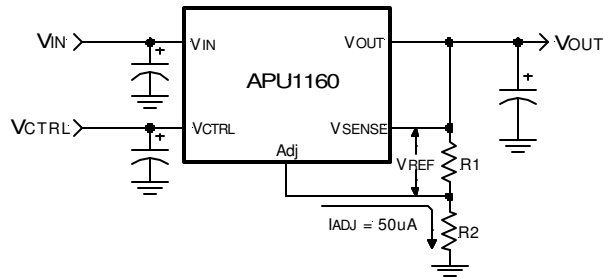

Figure 3 - Typical application of the APU1160 for programming the output voltage.

The APU1160 keeps a constant 1.25V between the V_{SENSE} pin and the V_{ADJ} pin. By placing a resistor R_1 across these two pins and connecting the V_{SENSE} and V_{OUT} pin together, a constant current flows through R_1 , adding to the I_{ADJ} current and into the R_2 resistor producing a voltage equal to the $(1.25/R_1) \times R_2 + I_{ADJ} \times R_2$. This voltage is then added to the 1.25V to set the output voltage. This is summarized in the above equation. Since the minimum load current requirement of the APU1160 is 10mA, R_1 is typically selected to be a 121 Ω resistor so that it automatically satisfies this condition. Notice that since the I_{ADJ} is typically in the range of 50 μA , it adds a small error to the output voltage and should be considered when very precise output voltage setting is required.

Load Regulation

Since the APU1160 has separate pins for the output (V_{OUT}) and the sense (V_{SENSE}), it is ideal for providing true remote sensing of the output voltage at the load. This means that the voltage drops due to parasitic resistance such as PCB traces between the regulator and the load are compensated for using remote sensing. Figure 4 shows a typical application of the APU1160 with remote sensing.

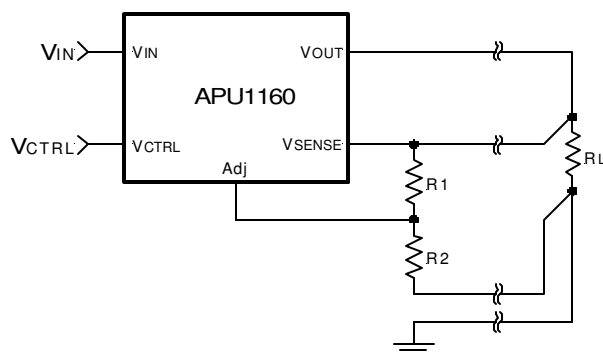

Figure 4 - Schematic showing connection for best load regulation.



Stability

The APU1160 requires the use of an output capacitor as part of the frequency compensation in order to make the regulator stable. Typical designs for the microprocessor applications use standard electrolytic capacitors with typical ESR in the range of 50 to 100mΩ and an output capacitance of 500 to 1000μF. Fortunately as the capacitance increases, the ESR decreases resulting in a fixed RC time constant. The APU1160 takes advantage of this phenomena in making the overall regulator loop stable.

For most applications a minimum of 100μF aluminum electrolytic capacitor such as Sanyo, MVGX series, Panasonic FA series as well as the Nichicon PL series insures both stability and good transient response.

Thermal Design

The APU1160 incorporates an internal thermal shutdown that protects the device when the junction temperature exceeds the allowable maximum junction temperature. Although this device can operate with junction temperatures in the range of 150°C, it is recommended that the selected heat sink be chosen such that during maximum continuous load operation the junction temperature is kept below this number. The example below shows the steps in selecting the proper surface mount package.

Assuming, the following conditions:

$$V_{OUT} = 2.8V$$

$$V_{IN} = 3.3V$$

$$V_{CTRL} = 5V$$

$$I_{OUT} = 3A \text{ (DC Avg)}$$

Calculate the maximum power dissipation using the following equation:

$$P_D = I_{OUT} \times (V_{IN} - V_{OUT}) + \left(\frac{I_{OUT}}{60} \right) \times (V_{CTRL} - V_{OUT})$$

$$P_D = 1 \times (3.3 - 2.8) + \left(\frac{3}{60} \right) \times (5 - 2.8) = 1.61W$$

Using table below select the proper package and the amount of copper board needed.

Pkg	Copper Area	θ _{JA} (°C/W)	Max Pd	Max Pd
			(T _A =25°C)	(T _A =45°C)
TO-263	1.4"X1.4"	25	4.4W	3.6W
TO-263	1.0"X1.0"	30	3.7W	3.0W
TO-263	0.7"X0.7"	35	3.1W	2.6W
TO-263	Pad Size	45	2.4W	2.0W

Note: Above table is based on the maximum junction temperature of 135°C.