



### FEATURES

- Ultra Low Dropout - 0.14V(Typical) at 1A Output Current
- Adjustable Mode: 1.22V Reference Voltage
- Fixed Mode : 5V, 9V, 12V Output Voltage
- Operating Voltage can be up to 23V.
- Current-Limit and Thermal Shutdown Protection
- Short Circuit Protection, Enable Function.
- Built-in Internal SW P-channel MOS
- SO-8, TO-220-5L and TO-220-5LR Pb-Free Package.

### DESCRIPTION

The APE8961 is a low-dropout voltage regulator suitable for various electronic equipments. It provides constant voltage power source. The dropout voltage of APE8961 is below 0.14V in full rated current (1A). This regulator has various functions such as a peak current protection, a thermal shut down, a short circuit protect.

The APE8961 is available in SO-8 and TO-220-5L power packages which features small size to reduce the junction-to-case resistance, being applicable in 0.5~3W applications.

### TYPICAL APPLICATION

#### 1.FIXED

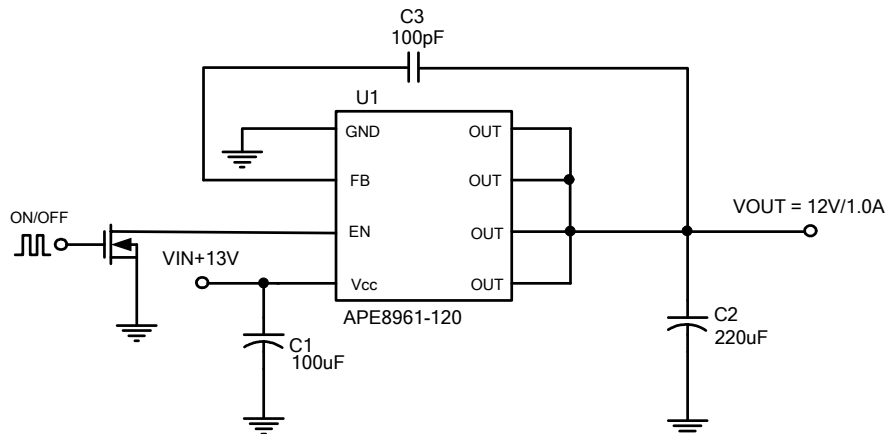

#### 2.ADJ

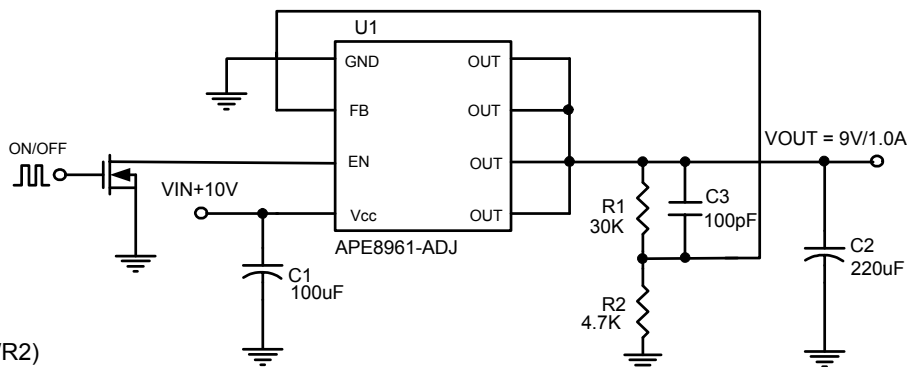

$$V_{OUT} = V_{FB} \times (1 + R1/R2)$$

$$V_{FB} = 1.22V$$

R2 suggest 1K~5.6KΩ

C2 choose Low ESR capacitor

C3=47pF~100pF for stability issue



**TYPICAL APPLICATION**

**3.FIXED (TO-220)**

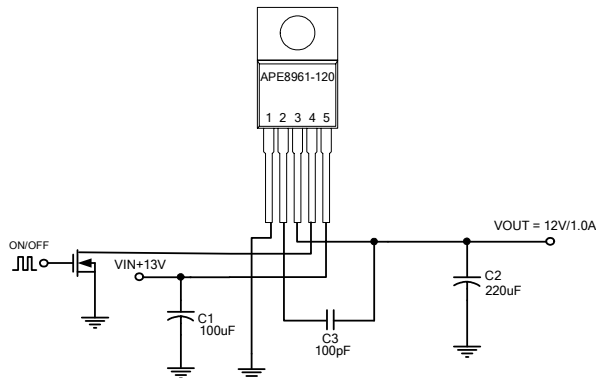

**4.ADJ (TO-220)**

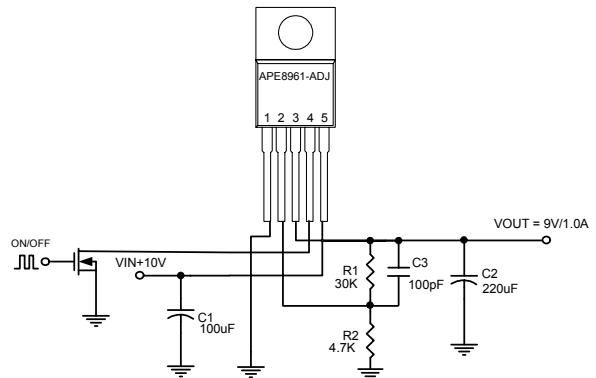

$$V_{OUT} = V_{FB} \times (1 + R1/R2)$$

$$V_{FB} = 1.22V$$

R2 suggest 1K~5.6KΩ  
C2 choose Low ESR capacitor  
C3=47pF~100pF for stability issue

**ABSOLUTE MAXIMUM RATINGS** (at T<sub>A</sub>=25°C)

V <sub>CC</sub> PIN Voltage(V <sub>CC</sub> )	-----	-0.3 to 25V
Feedback PIN Voltage(V <sub>FB</sub> )	-----	-0.3V to V <sub>CC</sub> + 0.3V
EN PIN Voltage(V <sub>EN</sub> )	-----	-0.3V to 7V
Power Dissipation(P <sub>D</sub> )	-----	SO-8            1.6W
		TO-220        4W
Storage Temperature Range(T <sub>ST</sub> )	-----	-65°C To 150°C
Operating Temperature Range(T <sub>OP</sub> )	-----	-40°C To 85°C
Junction Temperature Range(T <sub>J</sub> )	-----	-40°C To 125°C
Output Current (I <sub>OUT</sub> )	-----	1.5A
Thermal Resistance from Junction to Case(R <sub>thJC</sub> )		
	SO-8	20°C/W
	TO-220	3.5°C/W
Thermal Resistance from Junction to Ambient(R <sub>thJA</sub> )		
	SO-8	60°C/W
	TO-220	25°C/W

Note: R<sub>thJA</sub> is measured with the PCB copper area(need connect to OUT pin) of approximately 1.5 in2 (Multi-layer).

**ORDERING INFORMATION**

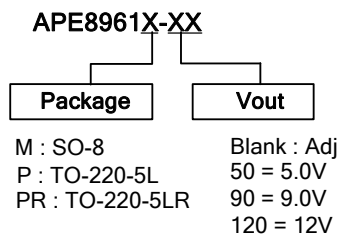



**PACKAGE INFORMATION**

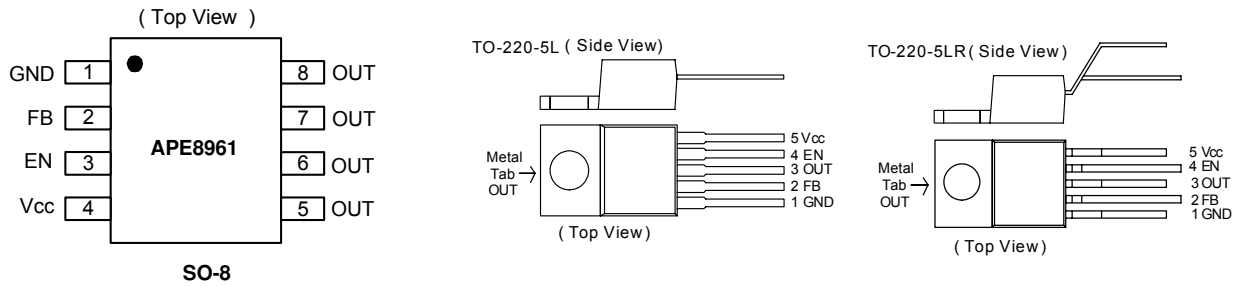

**ELECTRICAL SPECIFICATIONS** ( $V_{CC}=12V$ ,  $T_A=25^\circ C$ , unless otherwise specified)

Parameter	SYM	TEST CONDITION	MIN	TYP	MAX	UNITS
Vcc Supply Voltage	$V_{CC}$	$I_o=1A$	5.1	-	23	V
Feedback Voltage	$V_{FB}$	$I_o=10mA$ , $V_{CC}=10V$	1.196	1.22	1.244	V
Output Voltage	$V_{OUT}$	$I_o=10mA$ , $V_{CC}=6V$	4.9	5	5.1	V
		$I_o=10mA$ , $V_{CC}=10V$	8.82	9	9.18	
		$I_o=10mA$ , $V_{CC}=13V$	11.76	12	12.24	
GND Current	$I_{GND}$	$I_o = 0\sim 1A$	-	1.2	3	mA
Shutdown Current	$I_{SD}$	$V_{EN} = 0V$	-	0.15	0.4	mA
Load Regulation	$V_{Load}$	$5mA < I_o < 1A$	-	0.5	1.5	%
Line Regulation	$V_{Line}$	$I_o=10mA$ , $V_{OUT}+1.0V < V_{CC} < V_{OUT}+10V$	-	0.1	0.5	%
Ripple Rejection Ratio	PSRR	Note1	-	65	-	dB
Dropout Voltage	$V_{DROP}$	$I_o = 1A$ $V_{out}=5V$	-	0.14	0.2	V
		$I_o = 1A$ $V_{out}=9V$	-	0.13	0.19	
		$I_o = 1A$ $V_{out}=12V$	-	0.1	0.15	
Short circuit protect	$I_{scp}$	$V_{OUT}<20\%$	-	0.3	-	A
Current Limit	$I_L$		1.1	-	-	A
EN Pin Logic Input Threshold Voltage	$V_{ENH}$	High (regulator ON)	2	-	-	V
	$V_{ENL}$	Low (regulator OFF)	-	-	0.8	V
EN Pin Input Current	$I_{ENH}$	$V_{EN}=2.5V$ (ON)	-	20	-	uA
	$I_{ENL}$	$V_{EN}=0.3V$ (OFF)	-	-10	-	uA
Internal MOSFET RDSON	$R_{DSON}$	$V_{CC}=5.5V$	-	120	150	mΩ
		$V_{CC}=12V$	-	80	100	
Thermal Shutdown	TSD		-	140	-	°C

Note1. These parameters, although guaranteed, are not 100% tested in production.

**PIN DESCRIPTIONS**

PIN SYMBOL	PIN DESCRIPTION
GND	GND Pin
FB	Feedback Pin
EN	Power -Off Pin H : Normal Operation(Step-down) L : Step-down Operation Stopped (All circuits deactivated)
OUT	Output Voltage pin
VCC	IC Power Supply Pin



BLOCK DIAGRAM

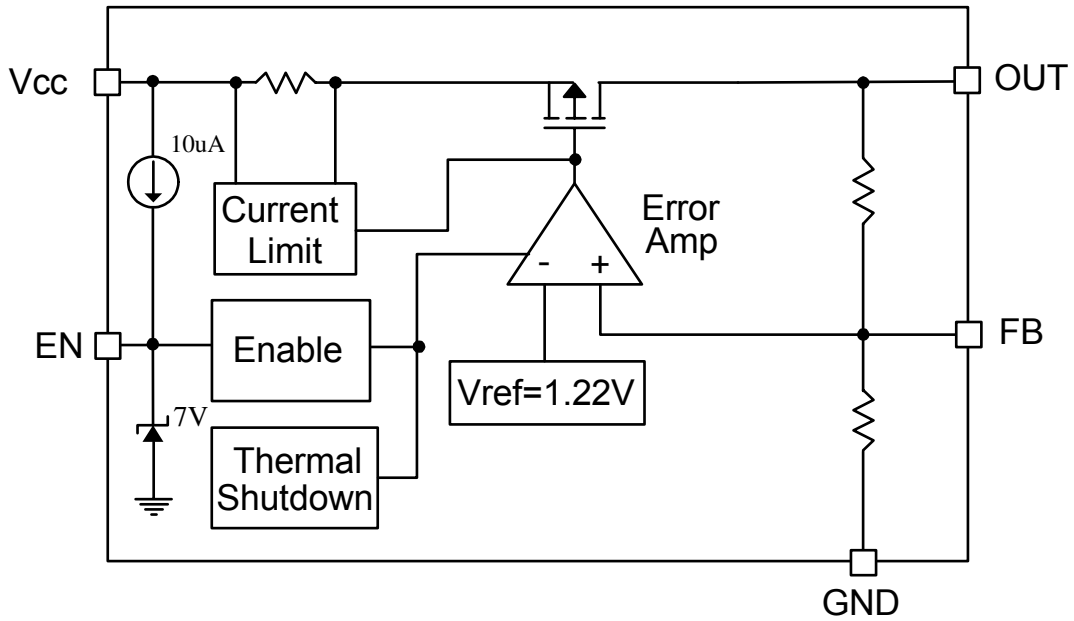



# TYPICAL PERFORMANCE CHARACTERISTICS

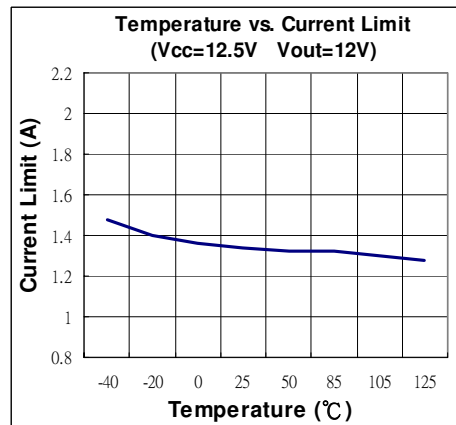
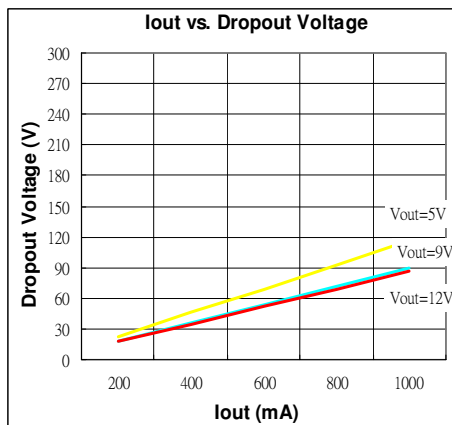
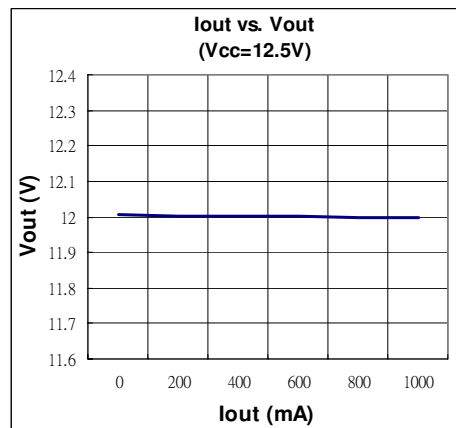
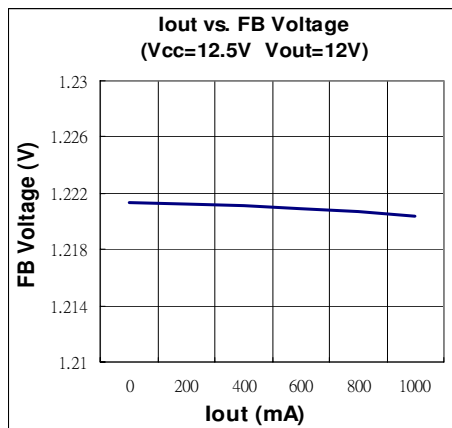
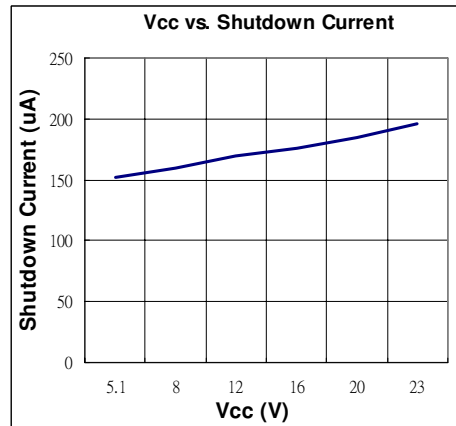
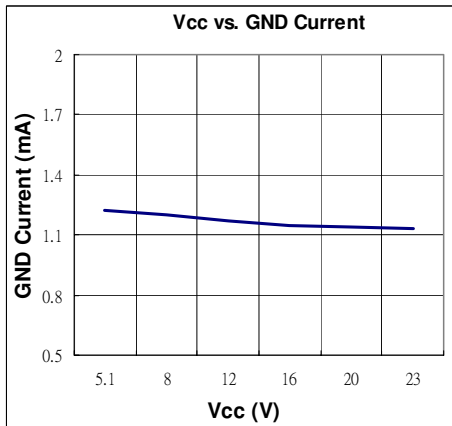



# TYPICAL PERFORMANCE CHARACTERISTICS

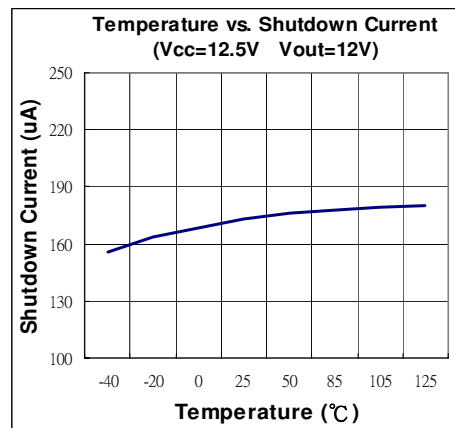
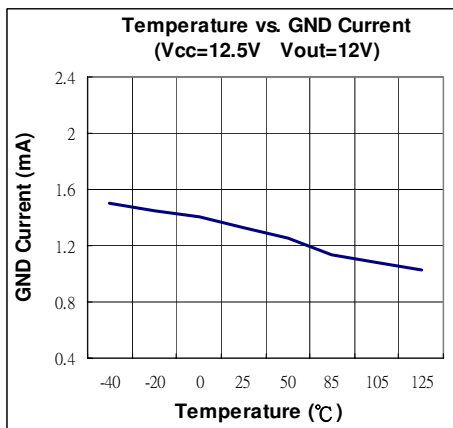
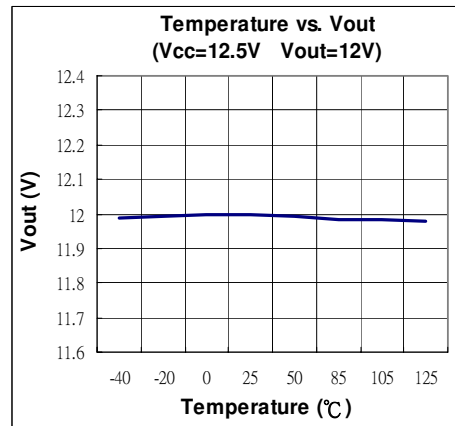
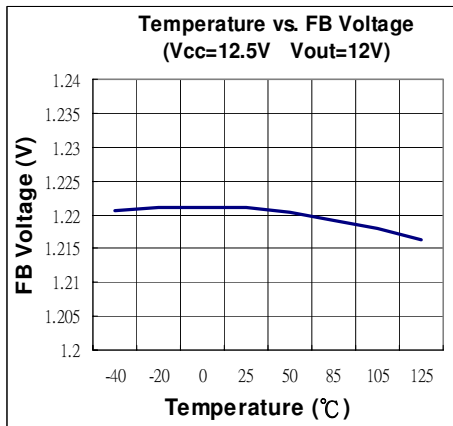

**Load Transient**  
(Vcc=12.5V Vout=12V Load=0.1~1A)

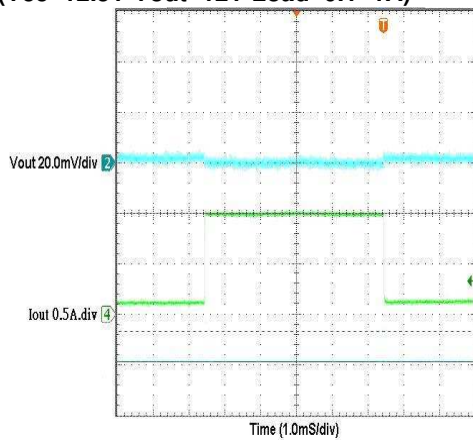

**Power-ON**  
(Vcc=12V Vout=9V Load=0.8A)

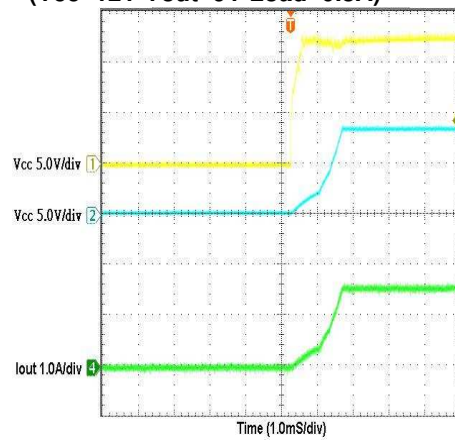



**PACKAGE OUTLINES (SO-8)**

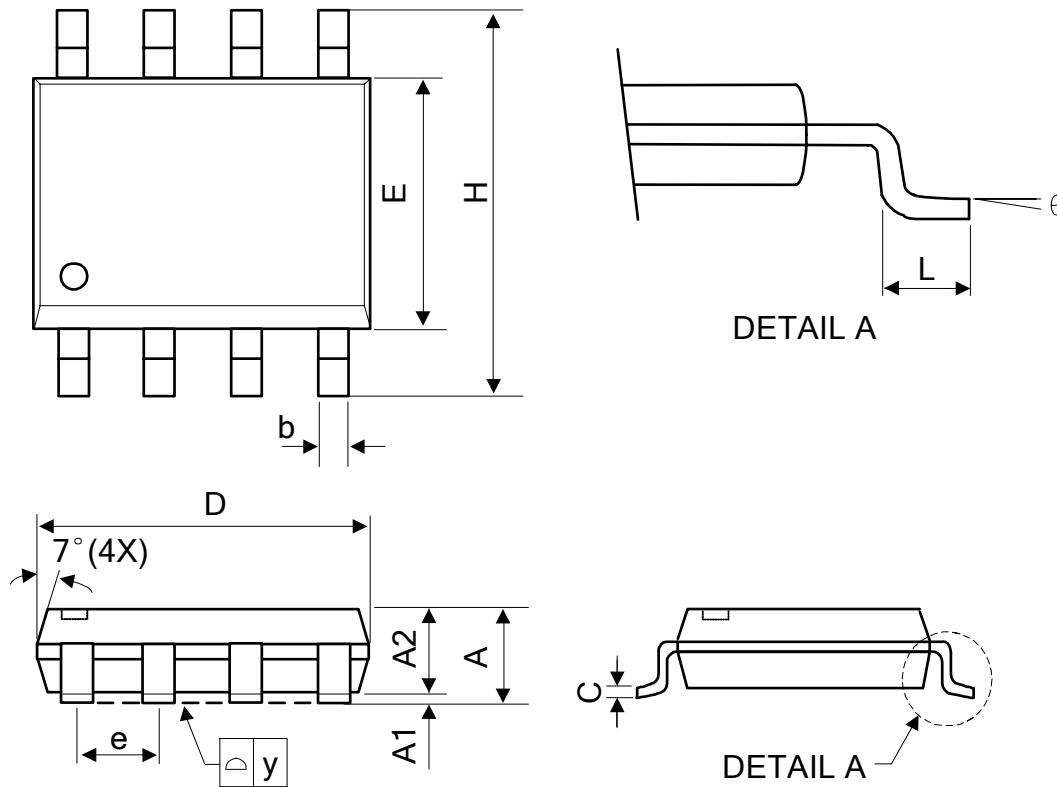

Symbol	Dimensions In Millimeters			Dimensions In Inches		
	Min.	Nom.	Max.	Min.	Nom.	Max.
A	1.40	1.60	1.75	0.055	0.063	0.069
A1	0.10	-	0.25	0.040	-	0.100
A2	1.30	1.45	1.50	0.051	0.057	0.059
C	0.19	0.20	0.25	0.0075	0.008	0.010
D	4.80	4.90	5.00	0.189	0.193	0.197
E	3.80	3.90	4.00	0.150	0.154	0.157
H	5.79	5.99	6.20	0.228	0.236	0.244
L	0.38	0.71	1.27	0.015	0.028	0.050
b	0.33	0.41	0.51	0.013	0.016	0.020
e	1.27 TYP			0.050 TYP		
y	-	-	0.10	-	-	0.004
θ	0°	-	8°	0°	-	8°

**Part Marking Information & Packing : SO-8**

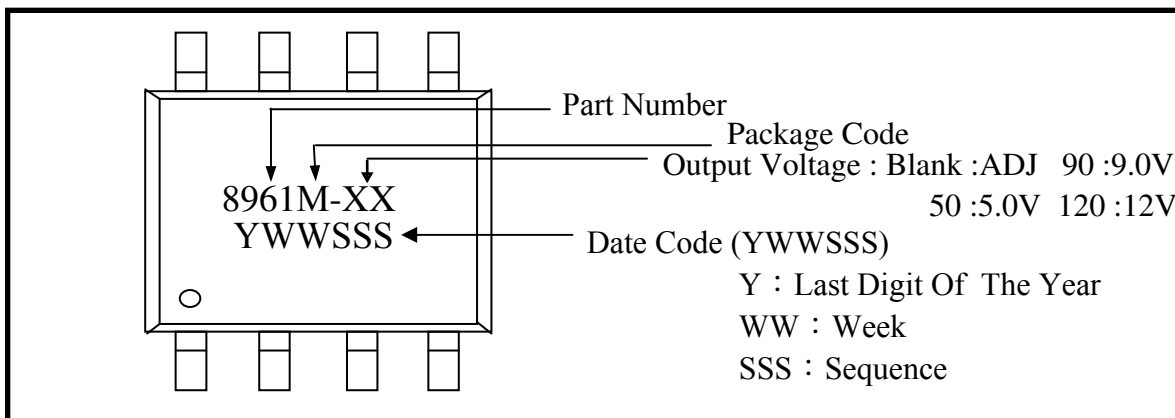



### PACKAGE OUTLINES (TO-220-5L)

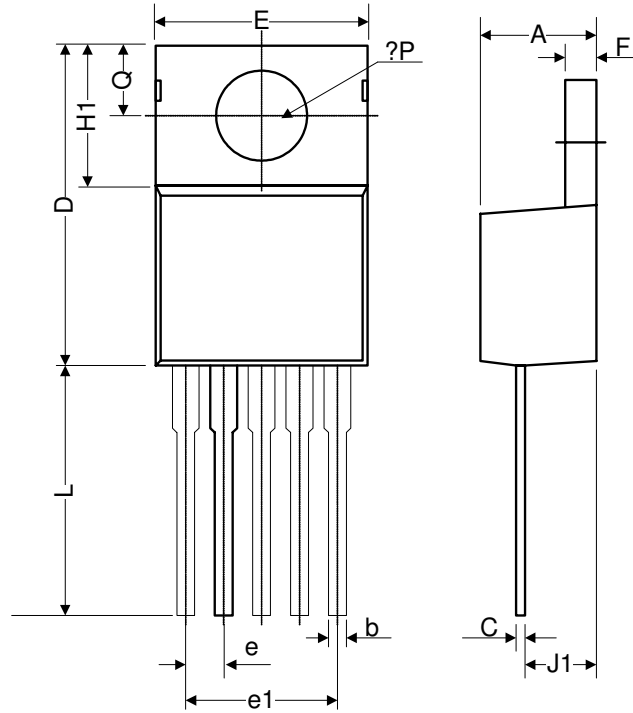

Symbol	Dimensions In Millimeters			Dimensions In Inches		
	Min.	Nom.	Max.	Min.	Nom.	Max.
A	4.07	4.45	4.82	0.160	0.175	0.190
b	0.76	0.89	1.02	0.030	0.035	0.040
C	0.36	0.50	0.64	0.014	0.020	0.025
D	14.22	14.86	15.50	0.560	0.585	0.610
E	9.78	10.16	10.54	0.385	0.400	0.415
e	1.57	1.71	1.85	0.062	0.067	0.073
e1	6.68	6.81	6.93	0.263	0.268	0.273
F	1.14	1.27	1.40	0.045	0.050	0.055
H1	5.46	6.16	6.86	0.215	0.243	0.270
J1	2.29	2.74	3.18	0.090	0.108	0.125
L	13.21	13.97	14.73	0.520	0.550	0.580
θP	3.68	3.81	3.94	0.145	0.150	0.155
Q	2.54	2.73	2.92	0.100	0.107	0.115

### Part Marking Information & Packing : TO-220-5L

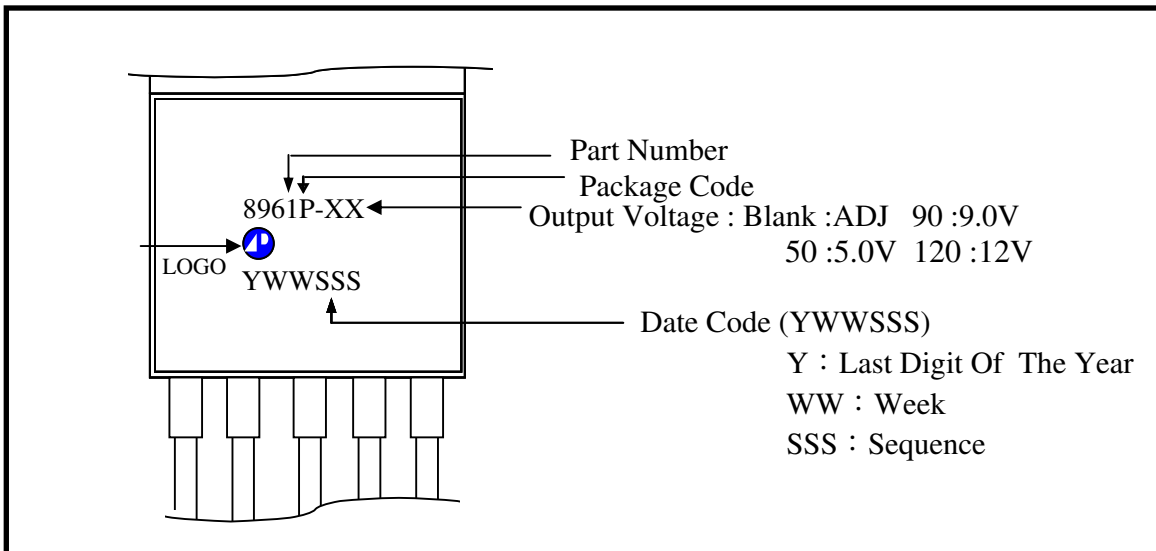



PACKAGE OUTLINES (TO-220-5LR)

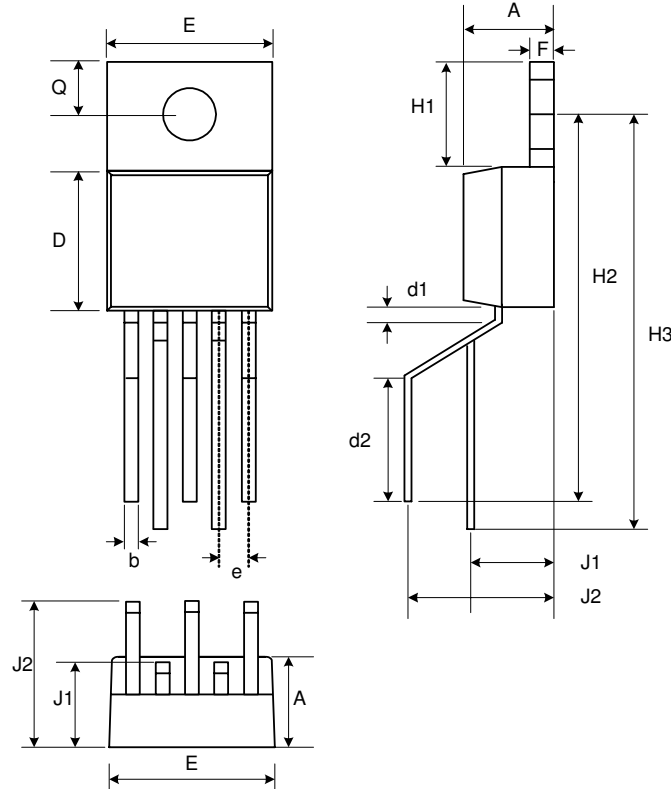

Symbol	Dimensions In Millimeters			Dimensions In Inches		
	Min.	Nom.	Max.	Min.	Nom.	Max.
A	4.4	4.6	4.7	0.175	0.180	0.185
b	0.7	0.8	0.9	0.027	0.032	0.037
D	8.4	8.7	8.9	0.330	0.340	0.350
d1	1.0			0.039		
d2	6.3			0.248		
E	9.91	10.16	10.41	0.390	0.400	0.410
e	1.6	1.7	1.8	0.062	0.067	0.072
F	1.2	1.25	1.3	0.048	0.050	0.052
H1	6.4			0.250		
H2	20.8	21.6	22.4	0.820	0.850	0.880
H3	23.9	24.7	25.5	0.942	0.972	1.002
J1	3.7	4.5	5.3	0.147	0.177	0.207
J2	8.4			0.331		
Q	2.5	2.8	3.0	0.100	0.110	0.120

Part Marking Information & Packing : TO-220-5LR

