



## 3A Ultra Low Dropout Positive Adjustable or Fixed-mode Regulator

### ■ Feature

- 0.7V maximum dropout voltage at 3A load current
- Built-in Thermal shutdown
- Output current limiting
- Adjustable or fixed output voltage 1.2V, 1.5V, 1.8V, 2.5V, 3.3V, 5.0V
- Fast transient response
- Good noise rejection
- Packages: TO252-5L, TO220-5L and TO263-5L
- Ro

### ■ General Description

APE1185 is a 3A regulator with extremely low dropout voltage. This product is specifically designed to provide well regulated supply for applications requiring 2.8V or lower voltages from 3.3V ATX power supplies where high efficiency of the switch can be achieved without the cost and complexity associated with switching regulator. One such application is the new graphic chipsets that requires anywhere from 2.4V to 2.7V supply.

### ■ Ordering Information

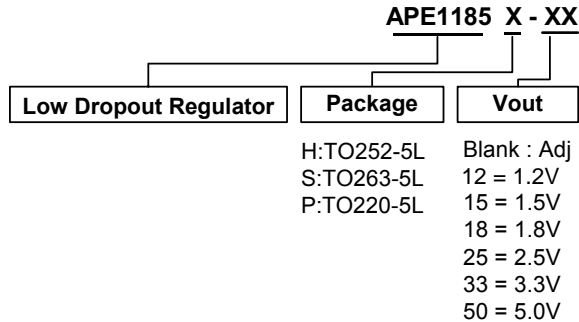

### ■ Typical Application

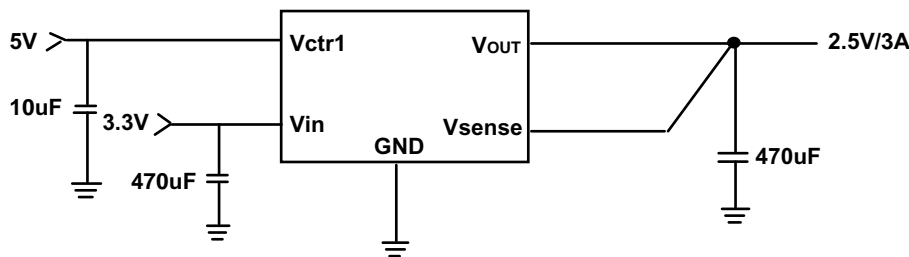

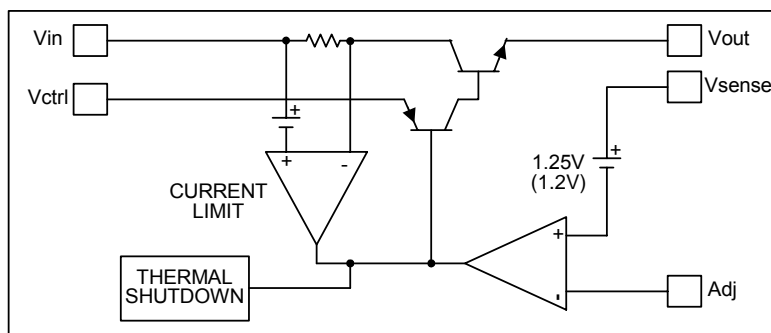
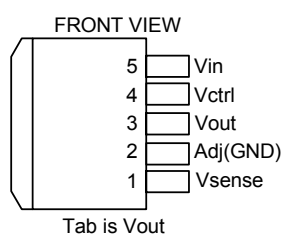
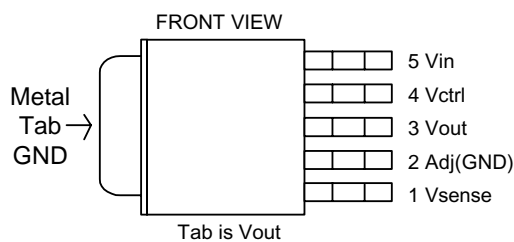
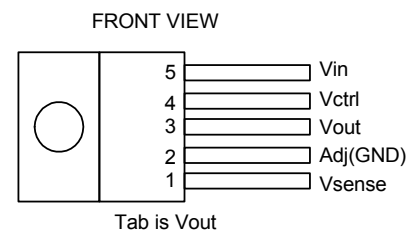
**3A Ultra Low Dropout Positive Adjustable or Fixed-mode Regulator**
**■ Block Diagram**

**■ Pin Configuration**

**(APE1185S)**

**( APE1185H )**

**(APE1185P)**
**■ Pin Descriptions**

Name	I/O	Description
Adj (GND)		A resistor divider from this pin to the Vout pin and ground sets the output voltage. (GND only for fixed mode)
Vsense	I	This pin is the positive side of the reference that allows remote load sensing to achieve excellent load regulation. A minimum of 10uF capacitor must be connected from this pin to ground to insure stability.
Vin	I	The input of the regulator. Typically a large storage capacitor is connected from this pin to ground to insure that the input voltage does not sag below the minimum dropout voltage during the load transient response. This pin must always be higher than Vout in order for the device to regulate.
Vctrl	I	This pin is the supply pin for the internal control circuit as well as the base drive for the pass transistor. This pin must always be higher than the Vout pin in order the device to regulate. A minimum of 100uF capacitor must be connected from this pin to ground to insure stability.
Vout	O	The output of the regulator. A minimum of 100uF capacitor must be connected from this pin to ground to insure stability.



**3A Ultra Low Dropout Positive Adjustable or Fixed-mode Regulator**

■ **Absolute Maximum Ratings**

Symbol	Parameter	Rating	Unit
$V_{IN}$	Input Voltage	16	V
$V_{ctrl}$	Control Input voltage	18	V
$P_D$	Power dissipation	Internally limited	
$T_{ST}$	Storage temperature Range	-65 to +150	°C
$T_{OP}$	Operation Junction Temperature Range	0 to +150	°C

■ **Electrical Characteristics**

Unless otherwise specified, these specifications apply over,  $C_{in}=1\mu F$ ,  $C_{out}=10\mu F$ , and  $T_J=0$  to  $150^\circ C$ . Typical value refer to  $T_J=25^\circ C$ .  $V_{out}=V_{sense}$ .

Sym.	Parameter	Test Condition	Min.	Typ.	Max.	Unit	
$V_{REF}$	Reference Voltage	APE1185-Adj $I_O=10mA$ , $T_J=25^\circ C$ , $(V_{in}-V_{out})=0.7V$ , $V_{ctrl}=V_{IN}+1V$	1.225	1.250	1.275	V	
	Line Regulation	APE1185-XX $I_O=10mA$ , $V_{OUT}+0.7V < V_{IN} < 12V$ , $T_J = 25^\circ C$ $V_{ctrl}=V_{IN}+1V$			0.5	%	
$V_{out}$	Output Voltage	APE1185-1.2 $I_{OUT} = 10mA$ , $T_J = 25^\circ C$ , $2.2V \leq V_{IN} \leq 12V$ $V_{ctrl}=V_{IN}+1V$	1.176	1.200	1.224	V	
		APE1185-1.5 $I_{OUT} = 10mA$ , $T_J = 25^\circ C$ , $2.2V \leq V_{IN} \leq 12V$ $V_{ctrl}=V_{IN}+1V$	1.470	1.500	1.530	V	
		APE1185-1.8 $I_{OUT} = 10mA$ , $T_J = 25^\circ C$ , $2.5V \leq V_{IN} \leq 12V$ $V_{ctrl}=V_{IN}+1V$	1.764	1.800	1.836	V	
		APE1185-2.5 $I_{OUT} = 10mA$ , $T_J = 25^\circ C$ , $3.2V \leq V_{IN} \leq 12V$ $V_{ctrl}=V_{IN}+1V$	2.450	2.500	2.550	V	
		APE1185-3.3 $I_{OUT} = 10mA$ , $T_J = 25^\circ C$ , $4.0V \leq V_{IN} \leq 12V$ $V_{ctrl}=V_{IN}+1V$	3.235	3.300	3.365	V	
		APE1185-5.0 $I_{OUT} = 10mA$ , $T_J = 25^\circ C$ , $5.7V \leq V_{IN} \leq 12V$ $V_{ctrl}=V_{IN}+1V$	4.900	5.000	5.100	V	
	Load Regulation	APE1185-Adj $0mA < I_O < 3A$ , $T_J = 25^\circ C$ $(V_{IN} - V_{OUT}) = 2V$ , $V_{ctrl} = V_{IN} + 1V$			1	%	
		APE1185-1.2 $V_{IN}=3V$ , $0mA < I_O < 3A$ , $T_J = 25^\circ C$ $V_{ctrl}=4V$		10	12	mV	
		APE1185-1.5 $V_{IN}=3V$ , $0mA < I_O < 3A$ , $T_J = 25^\circ C$ $V_{ctrl}=4V$		12	15	mV	
		APE1185-1.8 $V_{IN}=3.3V$ , $0mA < I_O < 3A$ , $T_J = 25^\circ C$ $V_{ctrl}=4.3V$		15	18	mV	
		APE1185-2.5 $V_{IN}=4V$ , $0mA < I_O < 3A$ , $T_J = 25^\circ C$ $V_{ctrl}=5V$		20	25	mV	
		APE1185-3.3 $V_{IN} = 5V$ , $0mA < I_O < 3A$ , $T_J = 25^\circ C$ $V_{ctrl}=6V$		26	33	mV	
		APE1185-5.0 $V_{IN} = 8V$ , $0mA < I_O < 3A$ , $T_J = 25^\circ C$ $V_{ctrl}=9V$		40	50	mV	
	Dropout Voltage ( $V_{ctrl} - V_{out}$ )	$V_{adj}=0V$ for all conditions below. $V_{in}=2.05V$ , $I_O=1.5A$ $V_{in}=2.05V$ , $I_O=2A$ $V_{in}=2.05V$ , $I_O=3A$		1.25	1.15 1.25 1.40	V	
			$V_{adj}=0V$ for all conditions below. $V_{ctrl} = 2.75V$ , $I_O=1.5A$ $V_{ctrl} = 2.75V$ , $I_O=2A$ $V_{ctrl} = 2.75V$ , $I_O=3A$		0.26 0.50 0.70	0.38 0.60 0.85	V
			Current Limit	$V_{ctrl} = 2.75V$ , $V_{in}=2.05V$ , $\Delta V_O=100mV$ , $V_{adj}=0V$	3.5		
	Minimum Load Current	$V_{ctrl} = 5V$ , $V_{in}=3.3V$ , $V_{adj}=0V$		5	10	mA	



**3A Ultra Low Dropout Positive Adjustable or Fixed-mode Regulator**

**■ Electrical Characteristics(Continued)**

Unless otherwise specified, these specifications apply over,  $C_{in}=1\mu F$ ,  $C_{out}=10\mu F$ , and  $T_j=0$  to  $150^\circ C$ . Typical value refer to  $T_j=25^\circ C$ .  $V_{out}=V_{sense}$ .

Sym.	Parameter	Test Condition	Min.	Typ.	Max.	Unit
	Thermal Regulation	30mS Pulse		0.01	0.02	%/W
	Ripple Rejection	$V_{ctrl}=5V$ , $V_{in}=5V$ , $I_o=3A$ , $V_{adj}=0V$ , $T_j=25$ , $V_{ripple}=1V_{pp}$ at 120Hz	60	70		dB
	Control Pin Current	$V_{adj}=0V$ for all conditions below. $V_{ctrl}=2.75V$ , $V_{in}=2.05V$ , $I_o=1.5A$ $V_{ctrl}=2.75V$ , $V_{in}=2.05V$ , $I_o=2A$ $V_{ctrl}=2.75V$ , $V_{in}=2.05V$ , $I_o=3A$		6 30 33	25 60 70	mA
$I_{adj}$	Adjust Pin Current	$V_{ctrl}=2.75V$ , $V_{in}=2.05V$ , $V_{adj}=0$		50	150	$\mu A$
$\theta_{JC}$	Thermal Resistance Junction-to-Case	TO-263: Control Circuitry/Power Transistor TO-220: Control Circuitry/Power Transistor TO-252: Control Circuitry/Power Transistor		2.7 2.7 10		$^\circ C/W$ $^\circ C/W$ $^\circ C/W$

**NOTE:**

APE1185-ADJ incorporates an internal thermal shutdown that protects the device when the junction temperature exceeds the allowable maximum junction temperature.

**■ Functional Descriptions**

**Introduction**

The APE1185 regulator is 5 terminal device designed specifically to provide extremely low dropout voltages comparable to the PNP type without the disadvantage of the extra power dissipation due to the base current associated with PNP regulators. This is done by bringing out the control pin of the regulator that provides the base current to the power NPN and connecting it to a voltage that is greater than the voltage present at the  $V_{in}$  pin. This flexibility makes the APE1185 ideal for applications where dual inputs are available such as a computer motherboard with an ATX style power supply that provides 5V and 3.3V to the board. One such application is the new graphic chip sets that require anywhere from 2.4V to 2.7V supply. The APE1185 can easily be programmed with the addition of two external resistors to any voltages within the range of 1.2V to 15.5V. Another major requirement of these graphic chips is the need to switch the load

current from zero to several amps in tens of nanoseconds at the processor pins, which translates to an approximately 300 to 500ns of current step at the regulator. In addition, the output voltage tolerances are also extremely tight and they include the transient response as part of the specification.

The APE1185 is specifically designed to meet the fast current transient needs as well as providing an accurate initial voltage, reducing the overall system cost with the need for fewer number of output capacitors. Another feature of the device is its true remote sensing capability that allows accurate voltage setting at the load rather than at the device.

**Output Voltage Setting**

The APE1185-ADJ can be programmed to any voltages in the range of 1.2V to 15.5V with the addition of R1 and R2 external resistors according to the following formula:



Functional Descriptions(Continued)

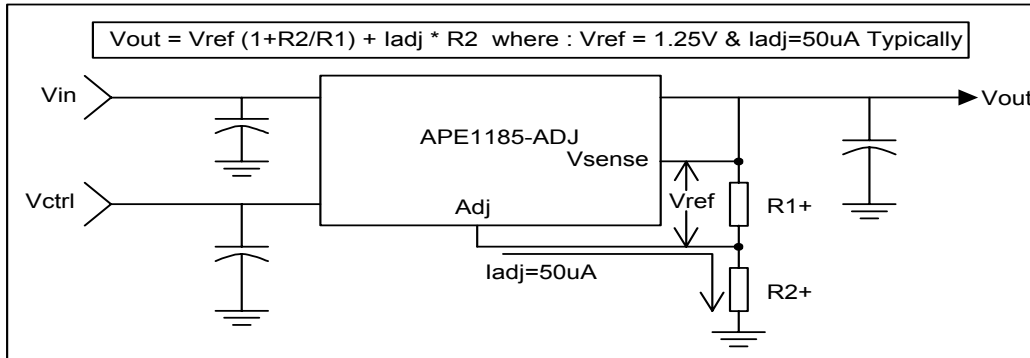

The APE1185-ADJ keeps a constant 1.25V between the Vsense pin and the Adj pin. By placing a resistor R1 across these two pins and connecting the Vsense and Vout pin together, a constant current flows through R1, adding to the Iadj current and into the R2 resistor producing a voltage equal to the  $(1.25/R1) \cdot R2 + I_{adj} \cdot R2$ . This voltage is then added to the 1.25V to set the output voltage. This is summarized in the above equation. Since the minimum load current requirement of the APE1185-ADJ is 10mA, R1 is typically selected to be a 121Ω resistor so that it automatically satisfies this condition. Notice that since the Iadj is typically in the range of 50uA it only adds a small error to the

output voltage and should be considered when very precise output voltage setting is required.

Load Regulation

Since the APE1185 has separate pins for the output (Vout) and the sense (Vsense), it is ideal for providing true remote sensing of the output voltage at the load. This means that the voltage drops due to parasitic resistance such as PCB traces between the regulator and the load are compensated for using remote sensing. Figure following shows a typical application of the APE1185-ADJ with remote sensing.

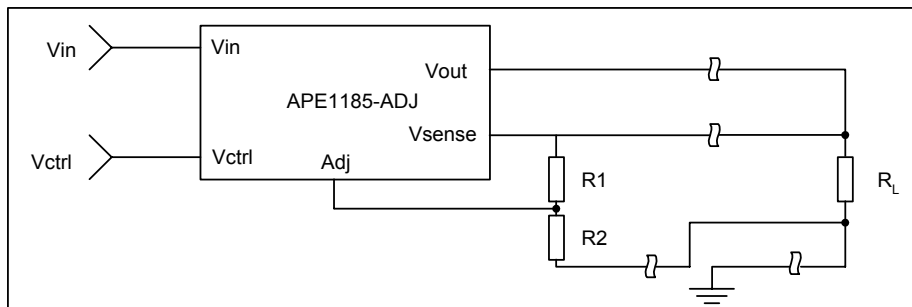

Stability

The APE1185-XX requires the use of an output capacitor as part of the frequency compensation in order to make the regulator stable. Typical designs for the microprocessor applications use standard electrolytic capacitors with typical ESR in the range of 50 to 100mΩ and an output capacitance of

100uF to 1000uF. Fortunately as the capacitance increases, the ESR decreases resulting in a fixed RC time constant. The APE1185-XX takes advantage of the phenomena in making the overall regulator loop stable. For most applications a minimum of 100uF aluminum electrolytic capacitor insures both stability and good transient response.



■ Performance Characteristic

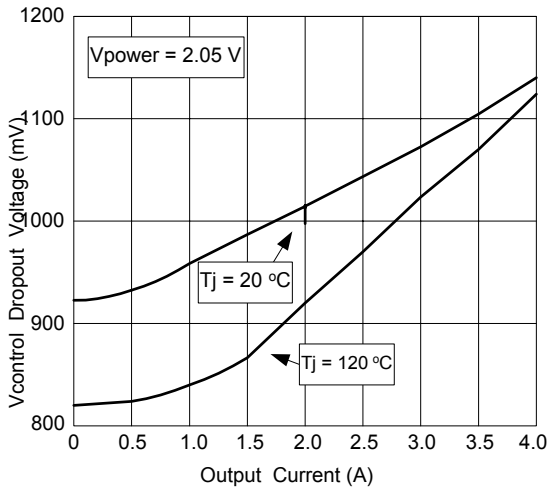

Vcontrol Dropout Voltage vs Output Current

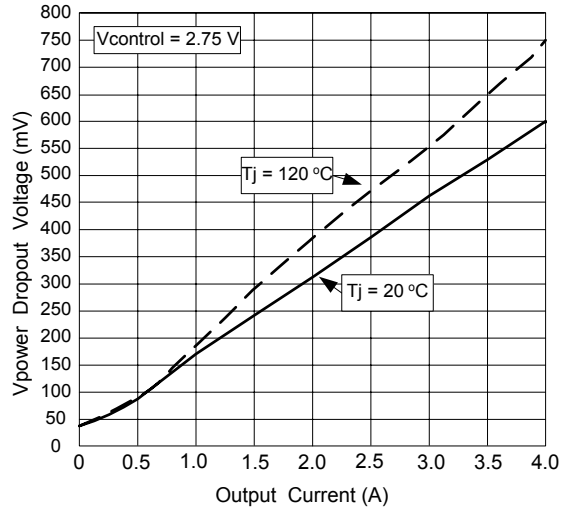

Vpower Dropout Voltage vs Output Current

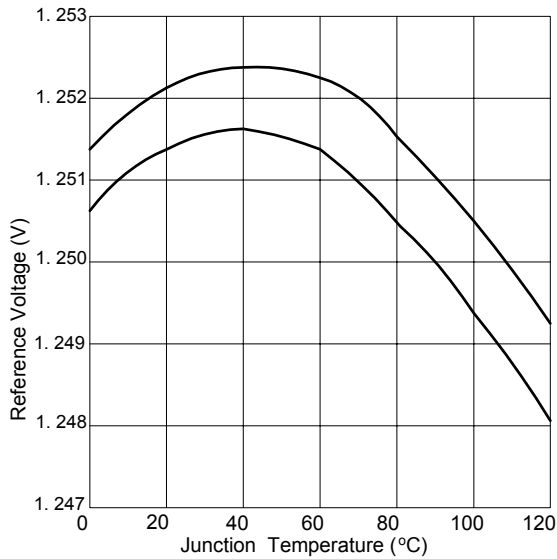

Reference Voltage vs Junction Temperature

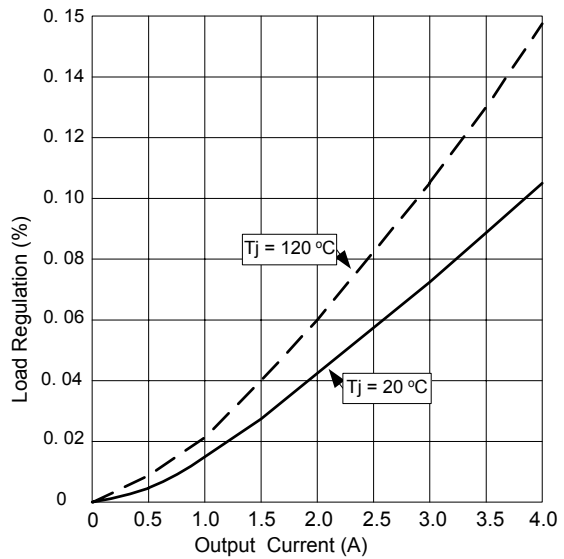

Load Regulation vs Output Current



■ Performance Characteristic (continued )

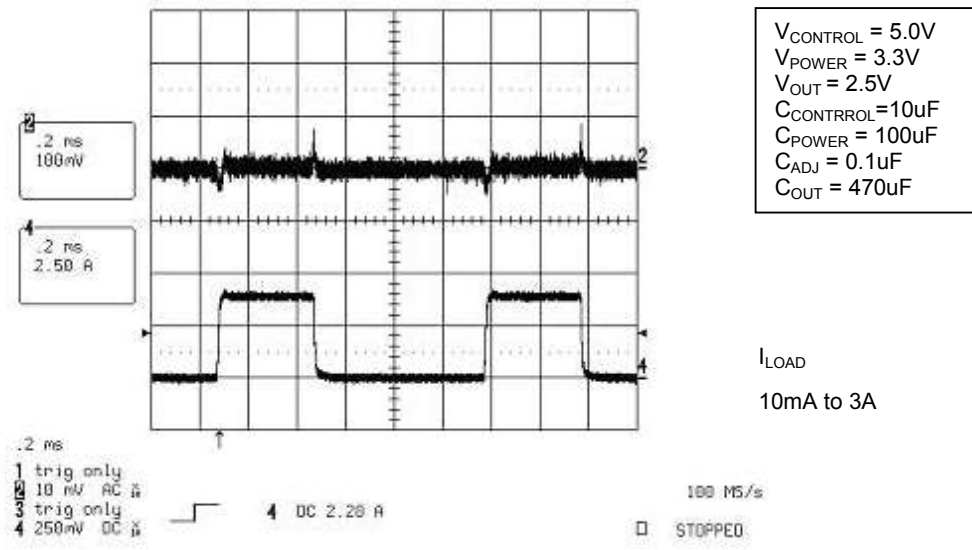

Transient Response

■ Marking Information

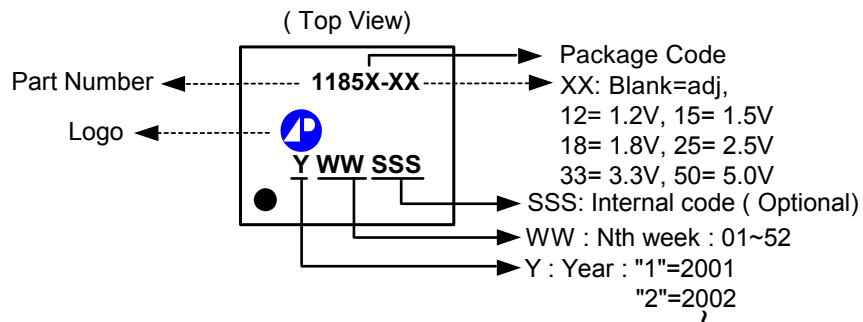

( TO252-5L / TO220-5L / TO263-5L )



## Package Outline : TO-263-5L

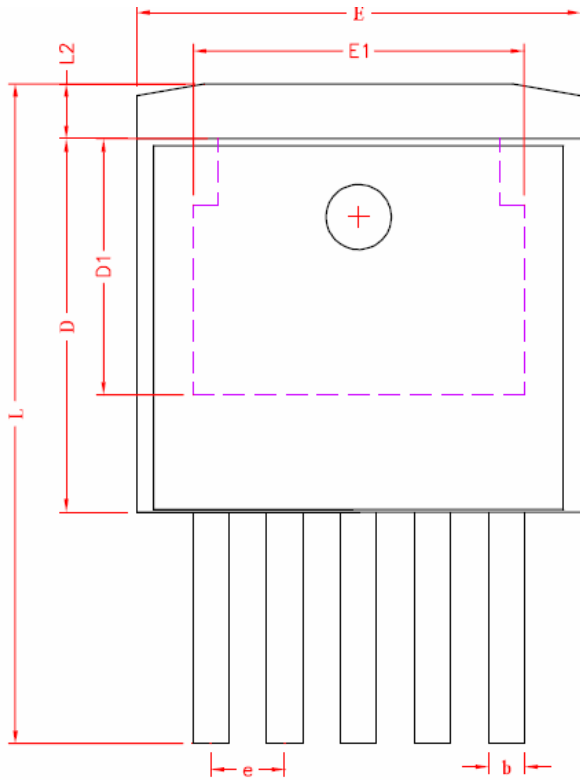

SYMBOLS	Millimeters		
	MIN	NOM	MAX
A	4.40	4.60	4.80
b	0.66	0.79	0.91
L4	0.00	0.15	0.30
c	0.36	0.43	0.50
L1	2.29	2.54	2.79
E	9.80	10.10	10.40
E1	7.60		
c2	1.25	1.35	1.45
L2	1.27		
D	8.60	8.80	9.00
D1	5.90		
e	1.70		
L	14.60	15.20	15.80
$\theta$	0°	4°	8°

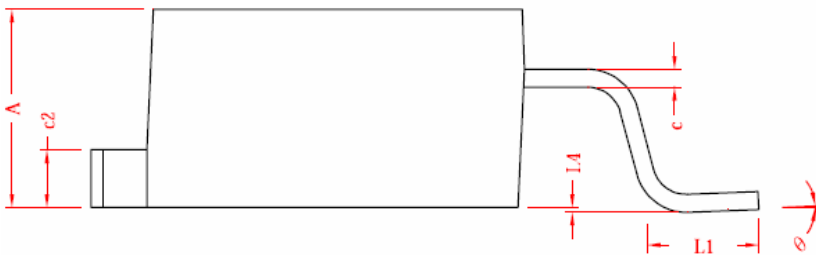

- 1.All Dimensions Are in Millimeters.
- 2.Dimension Does Not Include Mold Protrusions.

## Part Marking Information & Packing : TO-263-5L

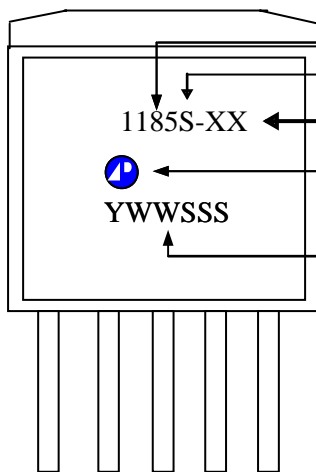

Part Number  
 Package Code  
 1185S-XX ← Output Voltage  
 LOGO  
 YWWSSS ← Date Code (YWWSSS)

Y : Last Digit Of The Year  
 WW : Week  
 SSS : Sequence



## Package Outline : TO-252(5L)

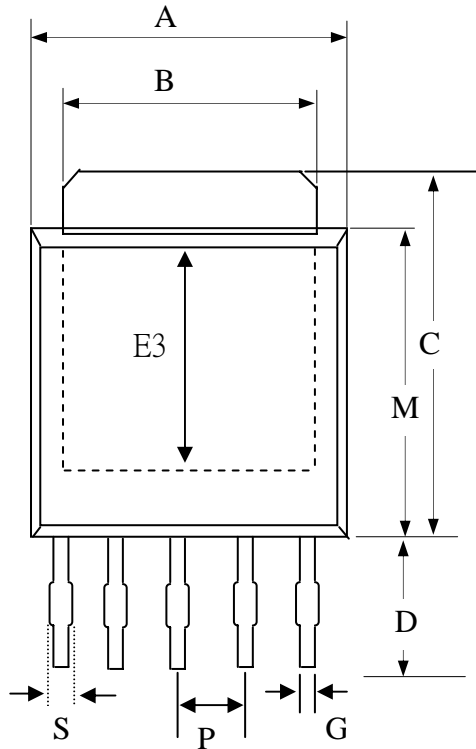

SYMBOLS	Millimeters		
	MIN	NOM	MAX
A	6.40	6.6	6.80
B	5.2	5.35	5.50
C	6.80	7.00	7.20
D	2.20	2.50	2.80
P	1.27 REF.		
S	0.50	0.65	0.80
E3	3.50	4.00	4.50
G	0.40	0.50	0.60
H	2.20	2.30	2.40
J	0.45	0.50	0.55
K	0.00	0.075	0.15
L	0.90	1.20	1.50
M	5.40	5.60	5.80

1.All Dimensions Are in Millimeters.

2.Dimension Does Not Include Mold Protrusions.

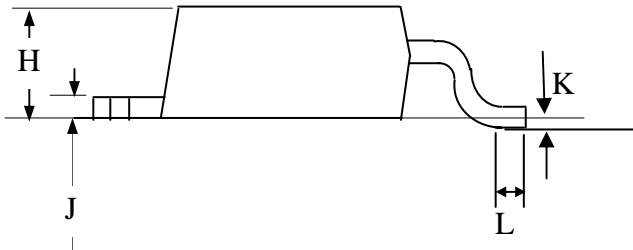

## Part Marking Information & Packing : TO-252(5L)

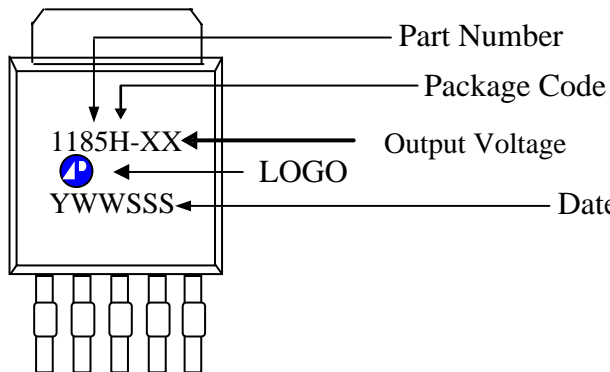

Y : Last Digit Of The Year

WW : Week

SSS : Sequence



### Package Outline : TO-220-5L

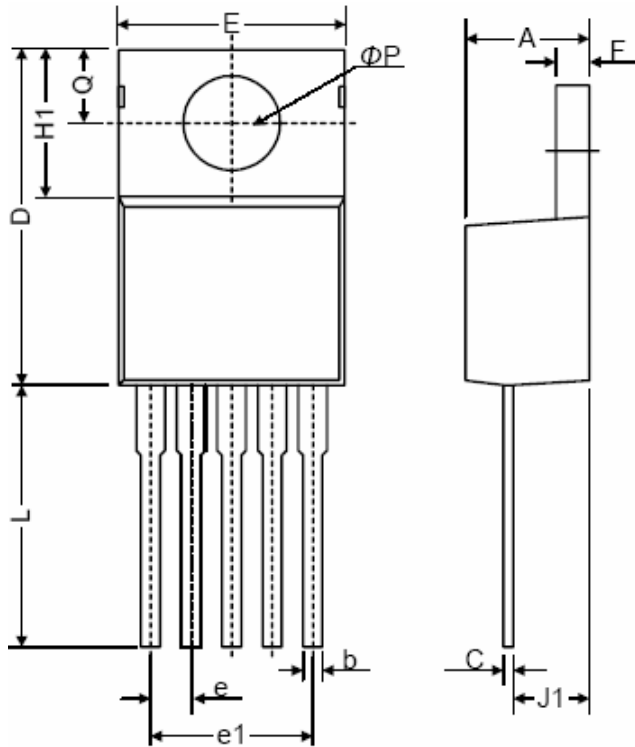

SYMBOLS	Millimeters		
	MIN	NOM	MAX
A	4.07	4.45	4.82
b	0.76	0.89	1.02
C	0.36	0.50	0.64
D	14.22	14.86	15.50
E	9.78	10.16	10.54
e	1.57	1.71	1.85
e1	6.68	6.81	6.93
F	1.14	1.27	1.40
H1	5.46	6.16	6.86
J1	2.29	2.74	3.18
L	13.21	13.97	14.73
$\phi p$	3.68	3.81	3.94
Q	2.54	2.73	2.92

1. All Dimensions Are in Millimeters.
2. Dimension Does Not Include Mold Protrusions.

### Part Marking Information & Packing : TO-220-5L

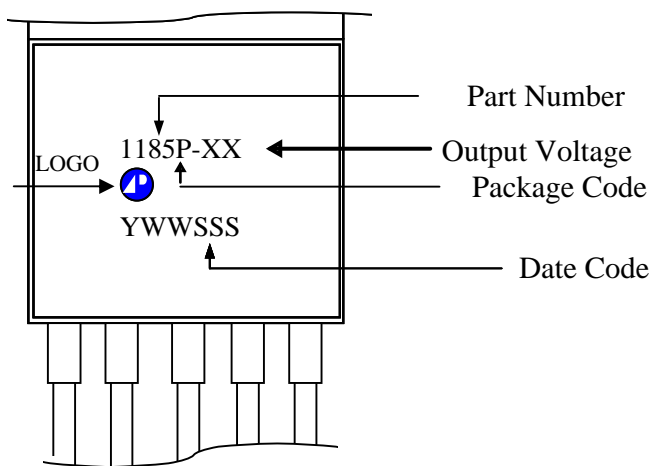

Y : Last Digit Of The Year  
 WW : Week  
 SSS : Sequence