



PWM CONTROL 2A STEP-DOWN CONVERTER

FEATURES

- Input Voltage : 10V to 58V
- Output Voltage : 3.3V to 56V
- Duty Ratio : 0% to 100% PWM Control
- Enable and Soft-Start Function
- Current Limit, Short Circuit Protect (SCP) and Thermal Shutdown Protection
- Built-in Internal SW P-channel MOS.
- ESOP-8 Pb-Free Package

DESCRIPTION

APE1862/A consists of step-down switching regulator with PWM control. These device include a reference voltage source, oscillation circuit, error amplifier, internal PMOS and etc.

APE1862/A provides low-ripple power, high efficiency, and excellent transient characteristics. The PWM control circuit is able to the duty ratio linearly form 0 up to 100%. This converter is build out soft start function that prevents overshoot and inrush current at startup. An over current protect function and short circuit protect function are built inside, and when OCP or SCP happens, the operation frequency will be reduced. An external compensation is easily to system stable; the low ESR output capacitor can be used.

With the addition of an internal P-channel Power MOS, a coil, capacitors, and a diode connected externally, these ICs can function as step-down switching regulators. They serve as ideal power supply units for portable devices when coupled with the SOP-8L with exposed pad package, providing such outstanding features as low current consumption. Since this converter can accommodate an input voltage up to 58V, it is also suitable for the operation via an AC adapter.

TYPICAL APPLICATION

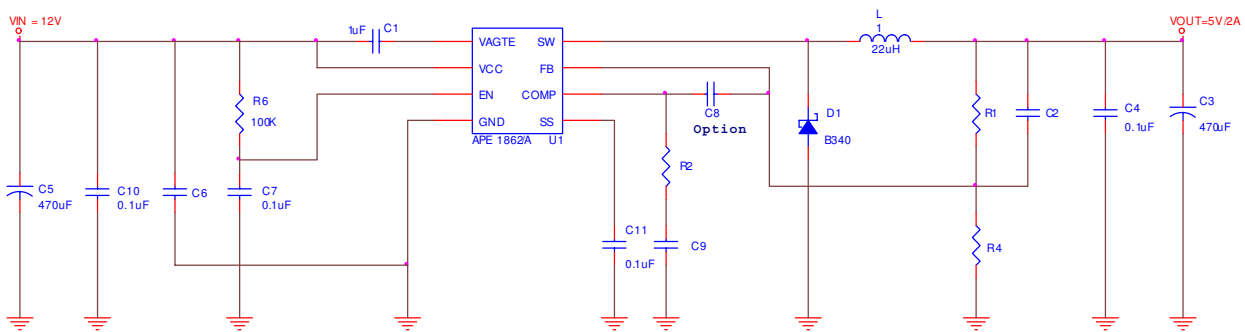

$$V_{OUT} = V_{FB} \times \left(1 + \frac{R1}{R4}\right)$$

$V_{FB} = 1.0V$; $R4$ suggest $0.8K \sim 3K$

EL Capacitor Compensation Table						
COUT ESR Range	FREQ	VOUT	R2	C9	C2	L1
30m~80mΩ	100KHz	5V	1K	47nF	2200pF	68uH
	250KHz		2.2K	47nF	560pF	33uH
80m~300mΩ	100KHz		1K	47nF	2200pF	68uH
	250KHz		2.2K	47nF	470pF	33uH

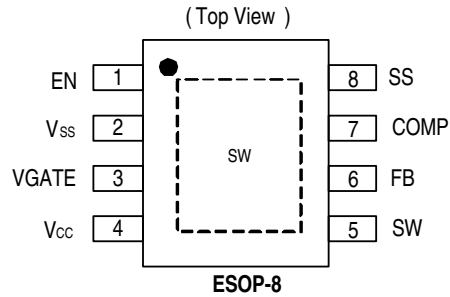
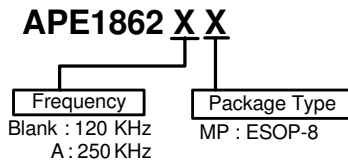
ORDERING / PACKAGE INFORMATION

ABSOLUTE MAXIMUM RATINGS (at $T_A=25^\circ\text{C}$)

V_{CC} Pin Voltage(V_{CC})	-----	$V_{SS} - 0.3\text{V}$ to $V_{SS} + 63\text{V}$
Feedback Pin Voltage(V_{FB})	-----	$V_{SS} - 0.3\text{V}$ to 6V
ON/OFF Pin Voltage(V_{EN})	-----	$V_{SS} - 0.3\text{V}$ to V_{CC}
SS Pin Voltage(V_{SS})	-----	$V_{SS} - 0.3\text{V}$ to 6V
COMP Pin Voltage(V_{COMP})	-----	$V_{SS} - 0.3\text{V}$ to 6V
GATE Pin Voltage(V_{GATE})	-----	$V_{SS} - 0.3\text{V}$ to V_{CC}
Switch Pin Voltage(V_{SW})	-----	$V_{SS} - 0.3\text{V}$ to $V_{CC} + 0.3\text{V}$
Power Dissipation(P_D)	-----	Internally Limited
Storage Temperature Range(T_{ST})	-----	-65°C To 150°C
Operating Junction Temperature Range(T_j)	-----	-40°C To 125°C
Operating Supply Voltage(V_{OP})	-----	$+10\text{V}$ to $+58\text{V}$
Thermal Resistance from Junction to Case($R_{th_{JC}}$)		15°C/W
Thermal Resistance from Junction to Ambient($R_{th_{JA}}$)		40°C/W

Note. $R_{th_{JA}}$ is measured with the PCB copper area (need connect to Exposed Pad) of approximately 1.5 in^2 (Multi-layer).

ELECTRICAL SPECIFICATIONS ($V_{CC}=24\text{V}$, $T_A=25^\circ\text{C}$, unless otherwise specified)

Characteristics	Symbol	Conditions	Min	Typ	Max	Units
Feedback Voltage	V_{FB}	$I_{OUT}=10\text{mA}$	0.98	1	1.02	V
Quiescent Current	I_{CCQ}	$V_{FB}=1.2\text{V}$ force driver off	-	3	6	mA
Feedback Bias Current	I_{FB}	$I_{OUT}=0.1\text{A}$	-	0.1	0.5	μA
Shutdown Supply Current	I_{SD}	$V_{EN}=0\text{V}$	-	0.5	1	mA
Line Regulation	$\Delta V_{OUT}/V_{OUT}$	$V_{CC}=10\text{V}\sim 58\text{V}$, $I_{OUT}=10\text{mA}$	-	0.3	0.6	%
Load Regulation	$\Delta V_{OUT}/V_{OUT}$	$I_{OUT}=0.2$ to 2A	-	0.3	0.6	%
Current Limit	I_{CL}		2.8	-	-	A
Oscillator Frequency	F_{OSC}	APE1862	90	120	150	KHz
	F_{OSC}	APE1862A	200	250	300	KHz
Short Frequency	F_{OSC1}	APE1862 I_{CL}	-	50	-	KHz
	F_{OSC1}	APE1862A I_{CL}	-	110	-	KHz
	F_{OSC2}	APE1862/APE1862A, $V_{FB} < 0.3$	-	30	-	KHz



ELECTRICAL SPECIFICATIONS(CONTINUED)

Parameter	SYM	TEST CONDITION	MIN	TYP	MAX	UNITS
EN Pin Logic Input Threshold Voltage	V_{SH}	Slew rate $\geq 65\text{mV/us}$	2	-	-	V
	V_{SL}	Slew rate $\geq 65\text{mV/us}$	-	-	0.8	
EN Pin Input Current	I_{SH}	$V_{EN}=2.5\text{V (ON)}$	-	5	-	μA
	I_{SL}	$V_{EN}=0.3\text{V (OFF)}$	-	5	-	
SS Current	I_{SS}	$V_{SS}=0\text{V}$	-	10	-	μA
Internal MOSFET R_{DSON}	R_{DSON}	$V_{CC}=12\text{V}, 1\text{A}, V_{FB}=0\text{V}$	-	220	300	$\text{m}\Omega$
Efficiency (APE1862)	EFFI	$V_{CC} = 24\text{V},$	-	90	-	%
		$V_{OUT} = 5\text{V}, I_{OUT} = 2\text{A}$				

PIN DESCRIPTIONS

PIN SYMBOL	PIN DESCRIPTION
V_{SS}	GND Pin
FB	Feedback Pin
EN	ON/OFF Shutdown
COMP	Compensation pin
SS	Soft-start pin
VGATE	Driver GATE clamping pin. The pin must connect a 1 μF capacitor to V_{CC}
SW	Switch pin. Connect external inductor and diode here.
V_{CC}	IC power supply pin

BLOCK DIAGRAM

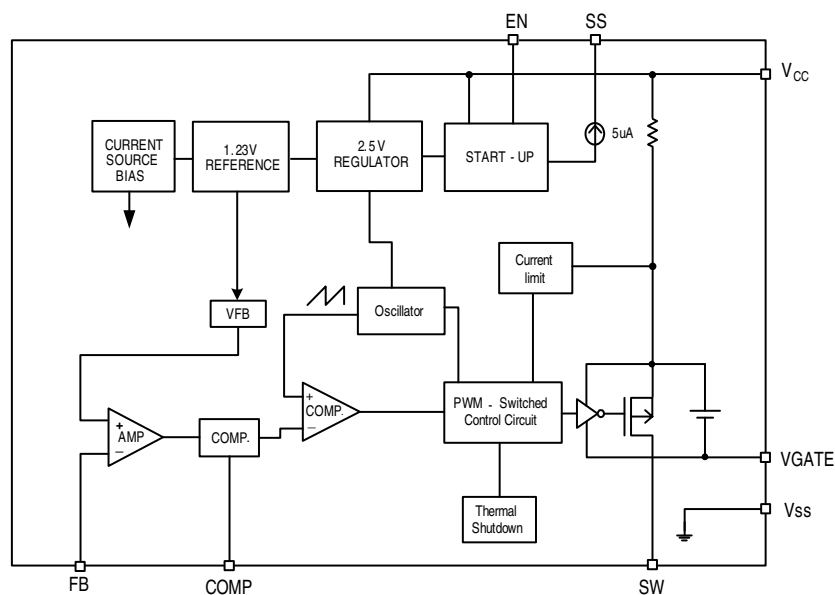



FUNCTION DESCRIPTION

EN

This pin can be supplied shutdown function. It is inside pull high function. Allow the switching regulator circuit to be shutdown pulling this pin below a 0.8V threshold voltage.

SS

This pin can be supplied soft start function. The pin must be connected a capacitor to ground. There is a 10uA current to charge this capacitor, vary the different capacitor value to control soft start time.

COMP

Compensation pin. For EL output capacitor application, the COMP pin connects R2 and C9 to ground for all condition; please refer the compensation table.

APPLICATION INFORMATION

Setting the Output Voltage

Application circuit item shows the basic application circuit with adjustable output version. The external resistor sets the output voltage according to the following equation:

$$V_{OUT} = 1.0V \times \left(1 + \frac{R1}{R4}\right)$$

Table 1 Resistor select for output voltage setting

V _{OUT}	R4	R1
5V	1.5K	6K
3.3V	1.3K	3K

Inductor Selection

For most designs, the different frequency can be reducing the inductor value; The APE1862/A is suggested 33μH. Where is inductor Ripple Current. Large value inductors lower ripple current and small value inductors result in high ripple currents. Choose inductor ripple current approximately 20% of the maximum load current 2A, ΔI_L=0.4A. The DC current rating of the inductor should be at least equal to the maximum load current plus half the ripple current to prevent core saturation (2A+0.2A).

Input Capacitor Selection

This capacitor should be located close to the IC using short leads and the voltage rating should be approximately 1.5 times the maximum input voltage. The RMS current rating requirement for the input capacitor of a buck regulator is approximately 1 / 2 the DC load current. A low ESR input capacitor sized for maximum RMS current must be used. A 470μF low ESR capacitor for most applications is sufficient.



APPLICATION INFORMATION

Output Capacitor Selection

The output capacitor is required to filter the output and provide regulator loop stability. The important capacitor parameters are; the 100 KHz Equivalent Series Resistance (ESR), the RMS ripples current rating, voltage rating, and capacitance value. For the output capacitor, the ESR value is the most important parameter. The ESR can be calculated from the following formula.

$$V_{RIPPLE} = \Delta I_L \times ESR = 0.4A \times 80m\Omega = 32mV$$

An aluminum electrolytic capacitor's ESR value is related to the capacitance and its voltage rating. In most case, higher voltage electrolytic capacitors have lower ESR values. Most of the time, capacitors with much higher voltage ratings may be needed to provide the low ESR values required for low output ripple voltage. It is recommended to replace this low ESR capacitor by using a 470 μ F low ESR values < 80m Ω .



TYPICAL PERFORMANCE CHARACTERISTICS

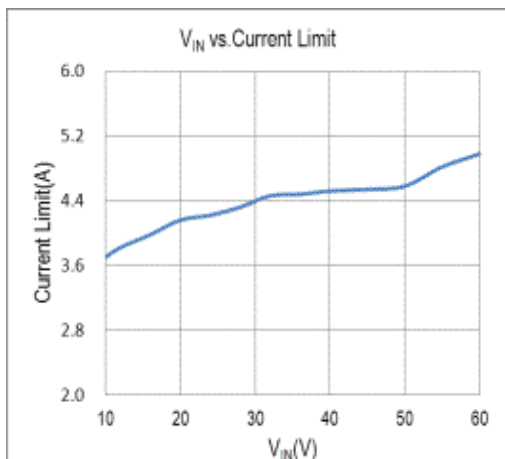
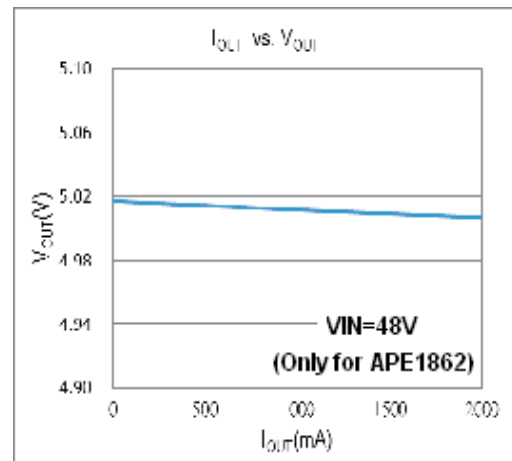
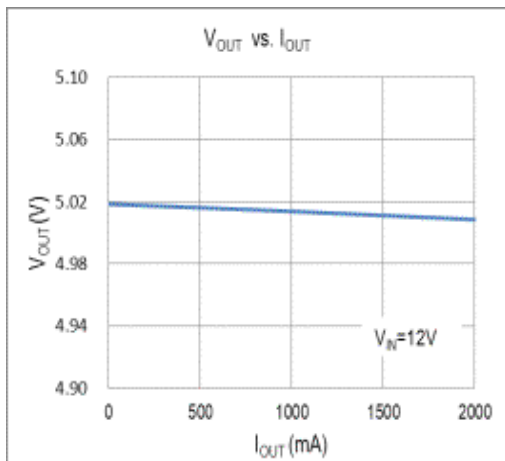
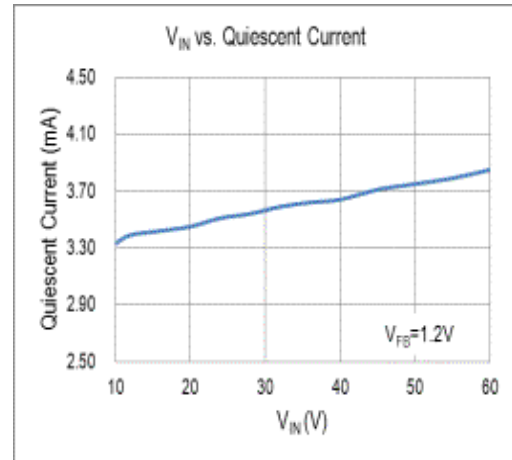
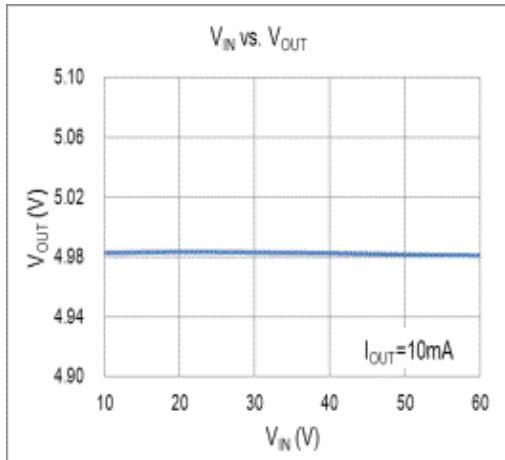



TYPICAL PERFORMANCE CHARACTERISTICS

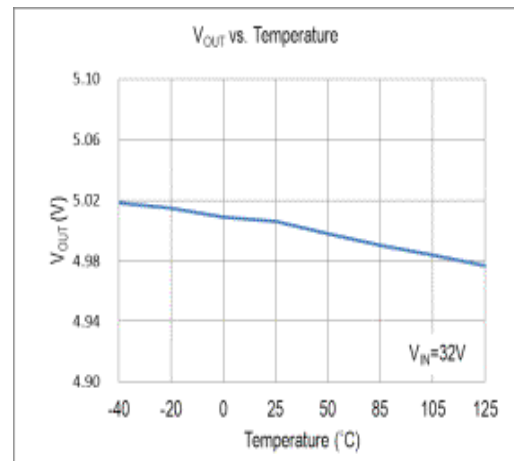
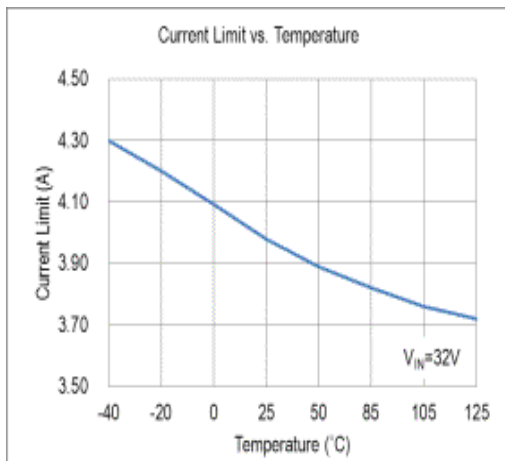
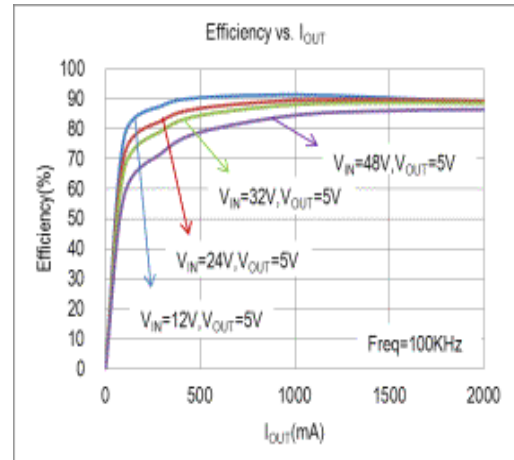
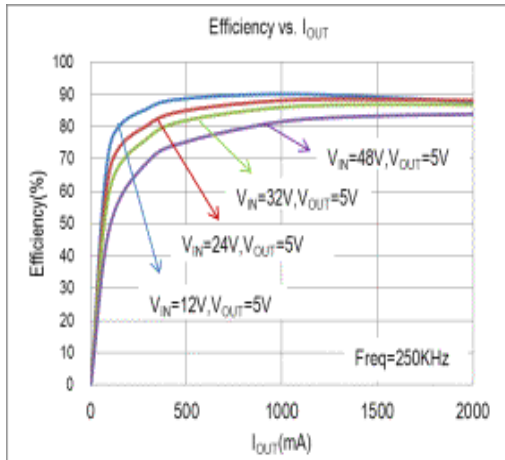



MARKING INFORMATION

ESOP-8

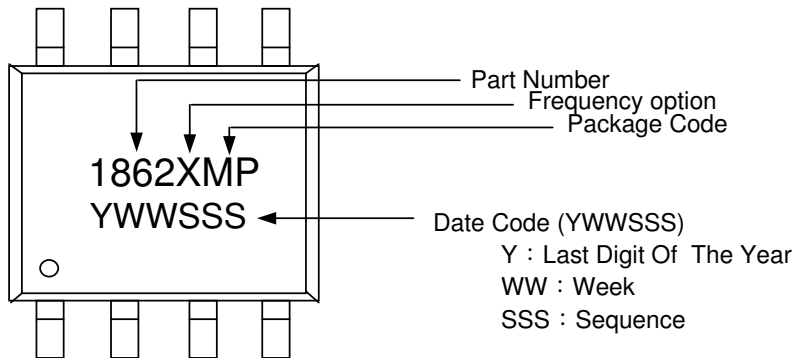



PACKAGE OUTLINES

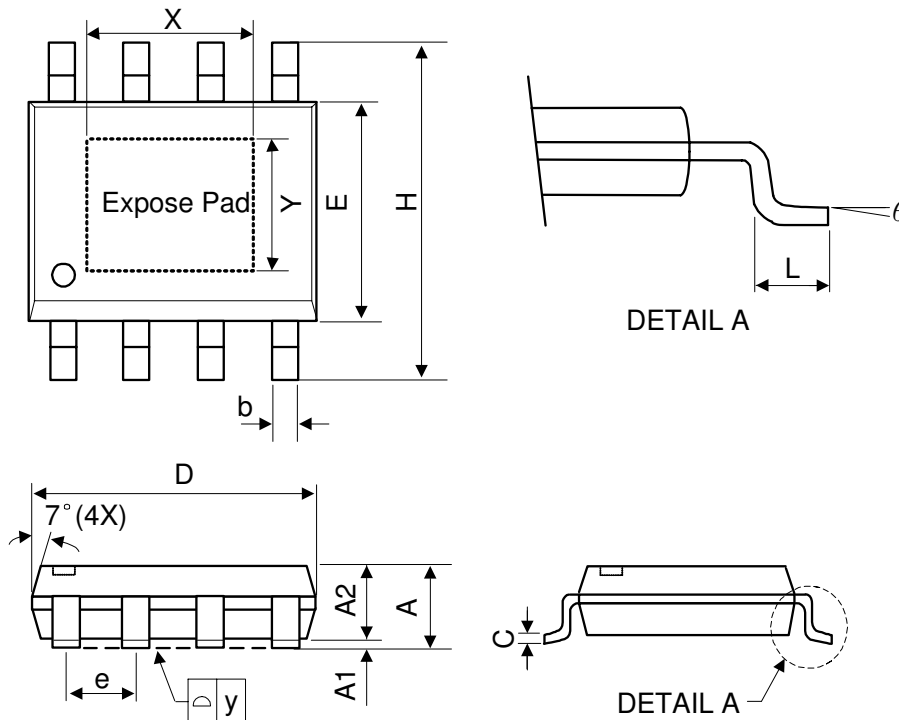

Symbol	Dimensions in Millimeters			Dimensions in Inches		
	Min.	Nom.	Max.	Min.	Nom.	Max.
A	-	-	1.75	-	-	0.069
A1	0	-	0.15	0	-	0.06
A2	1.25	-	-	0.049	-	-
C	0.1	0.2	0.25	0.0075	0.008	0.01
D	4.7	4.9	5.1	0.185	0.193	0.2
E	3.7	3.9	4.1	0.146	0.154	0.161
H	5.8	6	6.2	0.228	0.236	0.244
L	0.4	-	1.27	0.015	-	0.05
b	0.31	0.41	0.51	0.012	0.016	0.02
e	1.27 BSC			0.050 BSC		
y	-	-	0.1	-	-	0.004
X	-	2.34	-	-	0.092	-
Y	-	2.34	-	-	0.092	-
θ	0°	-	8°	0°	-	8°

Mold flash shall not exceed 0.25mm per side
JEDEC outline: MS-012 BA