



Adjustable Precision Shunt Regulator

Description

The AP432C is a low voltage three terminal adjustable shunt regulator with a guaranteed thermal stability over applicable temperature ranges. The output voltage can be set to any value between V_{REF} (approximately 1.24 V) to 8V with two external resistors. This device has a typical output impedance of 0.30Ω. Active output circuitry provides a very sharp turn on characteristic, making this device excellent replacement for Zener diodes in many applications.

The AP432C is characterized for operation from 0°C to 105°C, and four package options (SOT-23 and TO-92) allow the designer the opportunity to select the proper package for their applications.

Features

- Low voltage operation (1.24V)
- Adjustable output voltage $V_0 = V_{REF}$ to 8V
- Wide operating current range 60μA to 100mA
- Low dynamic output impedance 0.30Ω (Typ.)
- Trimmed bandgap design up to ± 0.5%.
- ESD rating is 2.5KV(Per MIL-STD-883D)
- RoHS Compliant and 100% Lead (Pb)-Free.

Application

- Linear Regulators
- Adjustable Supplies
- Switching Power Supplies
- Battery Operated Computers
- Instrumentation
- Computer Disk Drives

Pin Configuration

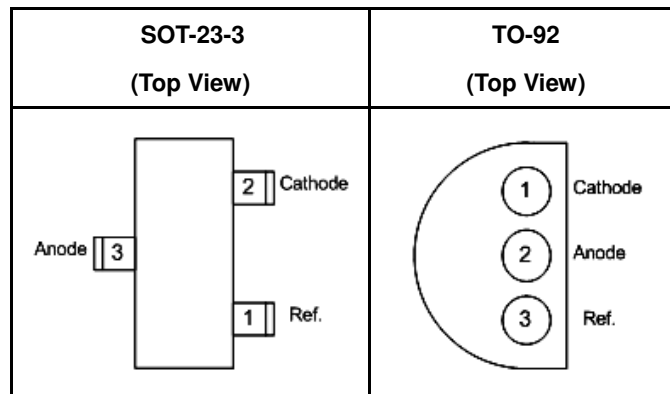

Ordering Information

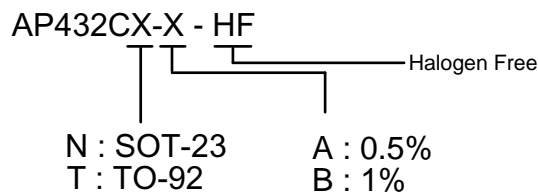

Absolute Maximum Rating

Parameter	Symbol	Maximum	Units
Cathode Voltage	V_{KA}	8	V
Continuous Cathode Current	I_{KA}	150	mA
Reference Current	I_{REF}	3	mA
Operating Junction Temperature Range	T_J	150	°C
Storage Temperature Range	T_{STG}	-45 to 150	°C
Thermal Resistance	θ_{JA}	230 (SOT-23-3)	°C/W
		220 (TO-92)	
Lead Temperature (Soldering) 10 seconds	T_{LEAD}	260	°C

Electrical Characteristics

Parameter		Symbol	Test Conditions & Circuit	Min	Typ	Max	Unit
Reference Voltage	0.5%	V_{REF}	Test circuit #1 $V_{KA} = V_{REF}, I_{KA} = 10mA$	1233	1240	1246	mV
	1.0%			1228	1240	1252	
Deviation of Reference Voltage over Full Temperature Range		$V_{I(DEV)}$	Test circuit #1 $V_{KA} = V_{REF}, I_{KA} = 10mA,$ $T_A = 0^\circ C - 105^\circ C$	--	10	25	mV
Ratio of Change in Reference Voltage to the Change in Cathode Voltage		$\Delta V_{REF}/\Delta V_{KA}$	Test circuit #2 $I_{KA} = 10mA, \Delta V_{KA} = 8V \text{ to } V_{REF}$	--	-1.0	-2.7	mV/V
Reference Current		I_{REF}	Test circuit #2 $I_{KA} = 10mA, R1=10k\Omega, R2 = \infty$	--	0.15	2	μA
Deviation of Reference Current over Full Temperature Range		$I_{I(DEV)}$	Test circuit #2 $I_{KA} = 10mA, R1=10k\Omega, R2 = \infty$ $T_A = 0^\circ C - 105^\circ C$	--	0.10	0.50	μA
Minimum Cathode Current for Regulation		I_{MIN}	Test circuit #1 $V_{KA} = V_{REF}$	--	60	100	μA
Off-state Cathode Current		I_{OFF}	Test circuit #3 $V_{KA} = 8V, V_{REF} = 0$	--	0.04	0.8	μA
Dynamic Impedance		$ Z_{KA} $	Test circuit #1 $I_{KA} = 100\mu A - 80mA,$ $V_{KA} = V_{REF}, f \leq 1kHz$	--	0.30	1	Ω

Note 1: Upon Customer Request.



Typical Performance Characteristics

Cathode Current VS Cathode Voltage

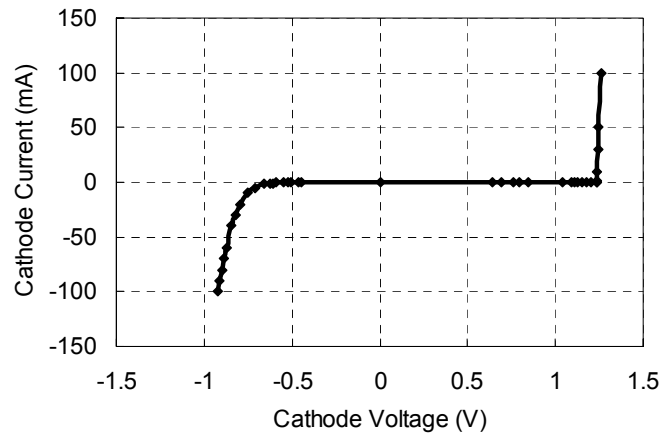

Reference Voltage VS Temperature
(Iload=10mA)

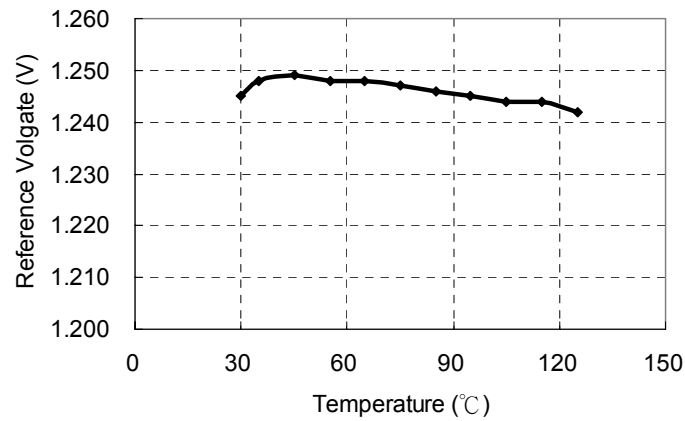

Reference Input Current VS Temperature
(R1=10K, R2=∞, Iload=10mA)

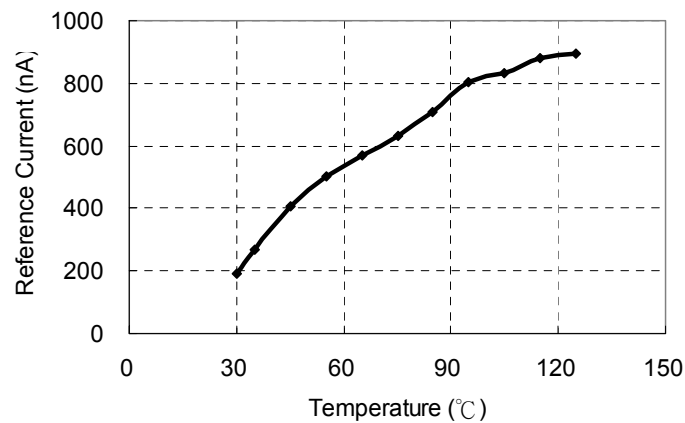

Stability Boundary Condition

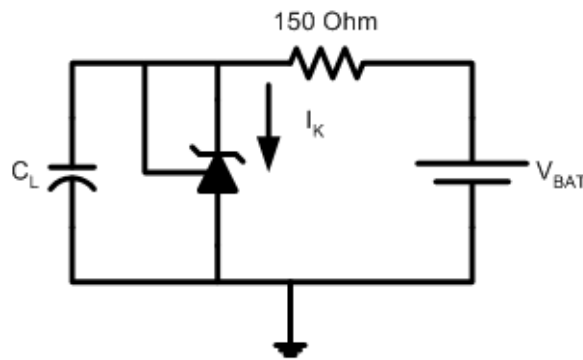
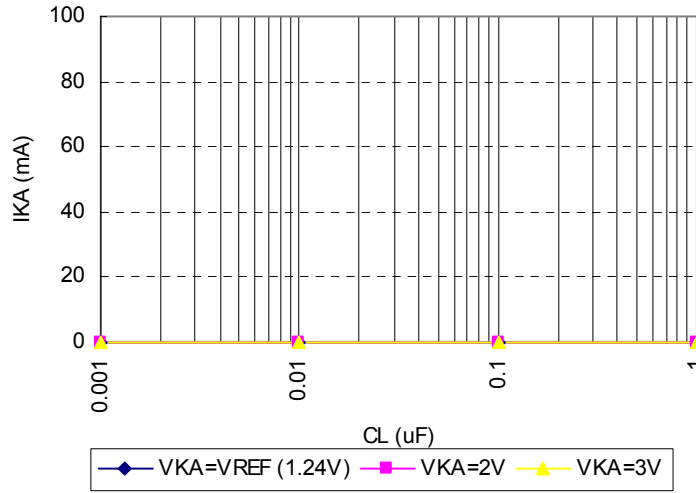

Test Circuit for $V_{KA} = V_{REF}$

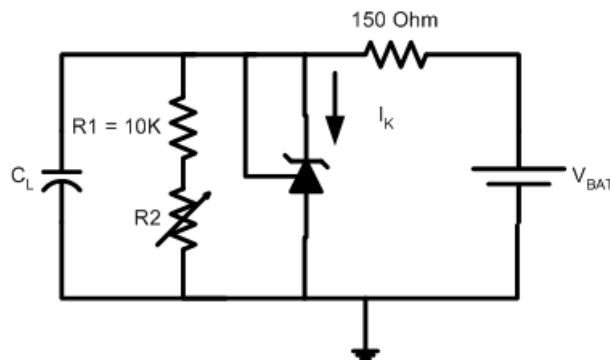

Test Circuit for $V_{KA} = 2\text{V}, 3\text{V}$

The areas under the curves represent conditions that may cause the device to oscillate. For $V_{KA} = 2\text{V}$ and 3V curves, R_2 and V_{BAT} were adjusted to establish the initial V_{KA} and I_K conditions with $C_L = 0$. V_{BAT} and C_L then were adjusted to determine the ranges of stability. As the graph suggested, AP432C is unconditional stable with I_K from 0 to 100mA and with C_L from 0.001 μF to 1 μF .



Symbol Diagram

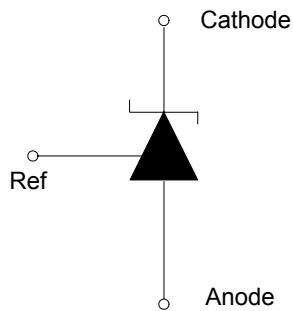

Block Diagram

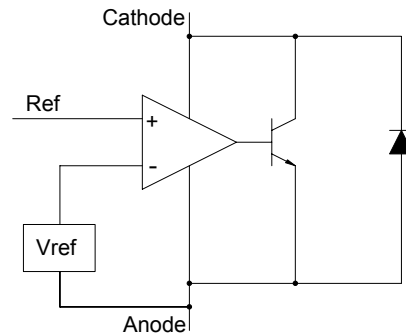

Test Circuits

<p>Test Circuit 1: $V_{KA} = V_{REF}$</p>	<p>Test Circuit 2: $V_{KA} > V_{REF}$</p>	<p>Test Circuit 3: Off State Current</p>

Application Circuit

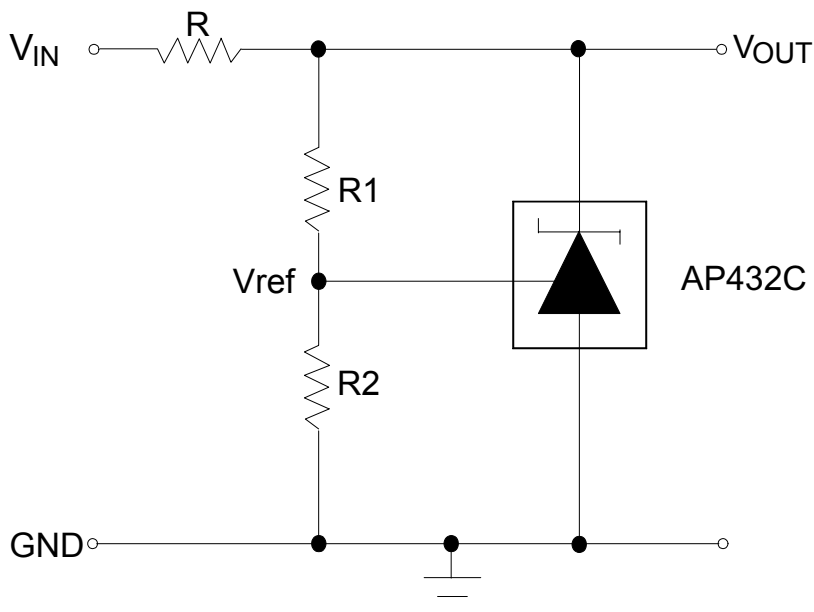

$V_{OUT} = V_{ref} (1 + \frac{R1}{R2})$



MARKING INFORMATION

SOT-23

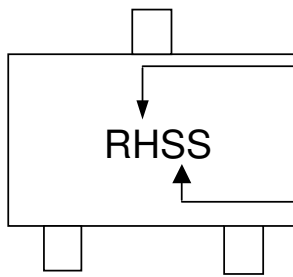

Part Number : RH

Date Code : SS

SS:2004,2008,2012...

SS:2003,2007,2011...

SS:2002,2006,2010...

SS:2001,2005,2009...

TO-92

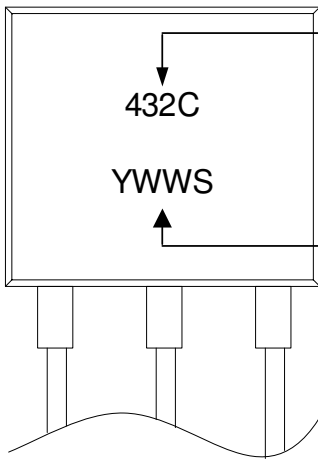

Part Number

Date Code (YWWS)

Y : Last Digit Of The Year

WW : Weak

S : Squence