



3PIN MICROPROCESSOR RESET CIRCUIT

FEATURES

- Precision Monitoring of +2.5,+3V, +3.3V, and +5V Power-Supply Voltages
- Fully Specified Over Temperature
- Available in Three Output Configurations
- Push-Pull RESET Low Output(APE6809/APE6811)
- Push-Pull RESET High Output(APE6810/APE6812)
- 200ms (Typ.)min Power-On Reset Pulse Width
- 25µA Supply Current
- Guaranteed Reset Valid to VCC = +1.0V
- Power Supply Transient Immunity
- No External Components
- Available in the 3-Pin Pb-Free SOT-23 and SC-70 Package
- Halogen-Free Product

DESCRIPTION

The APE6809_6812 are used for microprocessor (µP) supervisory circuits to monitor the power supplies in µP and digital systems. They provide excellent circuit reliability and low cost by eliminating external components and adjustments when used with +5V, +3.3V, +3.0V, +2.5V powered circuits.

These circuits perform a single function: they assert a reset signal whenever the VCC supply voltage declines below a preset threshold, keeping it asserted for at least 200ms after VCC has risen above the reset threshold. Reset thresholds suitable for operation with a variety of supply voltages are available. The APE6809_6812 have push pull outputs. The APE6809/APE6811 have an active low RESET output, while the APE6810_6812 has an active high RESET output. The reset comparator is designed to ignore fast transients on VCC, and the outputs are guaranteed to be in the correct logic state for VCC down to 1.0V. Low supply current makes the APE6809_6812 ideal for use in portable equipment. The APE6809_6812 is available in a 3-pin SOT-23 and SC-70 package.

TYPICAL APPLICATION

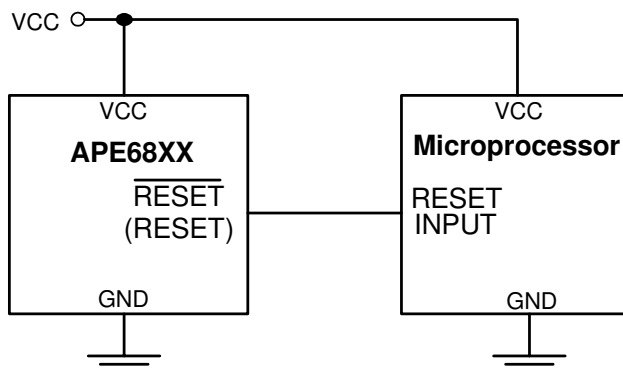

PACKAGE ORDERING INFORMATION

APE68XX X - X - HF			Halogen-Free
Enable	Package	Voltage	
09 : Active-Low	U : SC-70	A : 4.63	
10 : Active-High	N : SOT-23	B : 4.38	
11 : Active-Low		C : 4.00	
12 : Active-High		D : 3.08	
		E : 2.93	
		F : 2.63	
		G : 2.25	
		H : 2.70	
		I : 4.25	

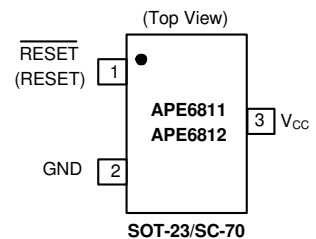
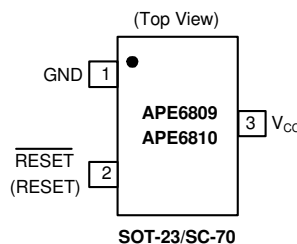



ABSOLUTE MAXIMUM RATINGS (at $T_A=25^\circ\text{C}$)

VCC PIN Voltage (V_{CC})	-----	GND - 0.3V to GND + 6.5V
RESET, $\overline{\text{RESET}}$ (Push-Pull) PIN Voltage (V_{RESET})	--	GND - 0.3V to VCC + 0.3V
Input Current, V_{CC} (I_{CC})	-----	20mA
Output Current, RESET, $\overline{\text{RESET}}$ (I_O)	-----	5mA
Power Dissipation(P_D)	-----	(T_J-T_A) / Rthja
Storage Temperature Range(T_{ST})	-----	-60 $^\circ\text{C}$ To 150 $^\circ\text{C}$
Operating Temperature Range(T_{OP})	-----	-40 $^\circ\text{C}$ To 85 $^\circ\text{C}$
Junction Temperature(T_J)	-----	-40 $^\circ\text{C}$ To 150 $^\circ\text{C}$
Thermal Resistance from Junction to case(R_{thJC})		110 $^\circ\text{C}/\text{W}$
Thermal Resistance from Junction to Ambient(R_{thJA})		250 $^\circ\text{C}/\text{W}$

Note. R_{thJA} is measured with the PCB copper area of approximately 1 in2(Multi-layer). that need connect to VSS pin.

ELECTRICAL SPECIFICATIONS

($V_{DD}=2.75\text{V}$, $T_A=25^\circ\text{C}$, unless otherwise specified)

Parameter	SYM	TEST CONDITION	MIN	TYP	MAX	UNITS
Operating Vcc Range	V_{Range}		1	-	6	V
Supply Current	I_{CC}	$V_{CC} = V_{TH}+1.0\text{V}$	-	25	35	μA
Reset Threshold $T_A=25^\circ\text{C}$	V_{TH}	APE6809_6812A	4.54	4.63	4.71	V
		APE6809_6812B	4.29	4.38	4.46	
		APE6809_6812I	4.16	4.25	4.33	
		APE6809_6812C	3.92	4	4.08	
		APE6809_6812D	3.02	3.08	3.15	
		APE6809_6812E	2.87	2.93	3	
		APE6809_6812H	2.64	2.7	2.75	
		APE6809_6812F	2.57	2.63	2.69	
APE6809_6812G	2.2	2.25	2.3			
Reset Threshold Tempco	V_{THT}	$T_A = 0^\circ\text{C}$ to $+85^\circ\text{C}$	-	50	-	ppm/ $^\circ\text{C}$
Set-up Time	T_S	$V_{CC} = 0$ to ($V_{TH} - 100\text{mV}$)	1	-	-	μs
Vcc to Reset Delay	T_{RD}	$V_{CC}=V_{TH}$ to ($V_{TH}-100\text{mV}$)	-	20	-	μs
Reset Active Timeout Period	T_{DELAY}	$T_A = 0^\circ\text{C}$ to $+85^\circ\text{C}$	160	200	260	ms
RESET Output Voltage (APE6809/APE6811)	V_{OL}	$1.8\text{V} < V_{CC} < V_{TH(\text{min})}$, $I_{\text{SINK}} = 1.2\text{mA}$	-	-	0.3	V
		$1.2\text{V} < V_{CC} < 1.8\text{V}$, $I_{\text{SINK}} = 50\mu\text{A}$				
RESET Output Voltage (APE6810/APE6812)	V_{OH}	$V_{CC} > V_{TH(\text{max})}$, $I_{\text{SOURCE}} = 500\mu\text{A}$,	0.8 V_{CC}	-	-	V
RESET Output Voltage (APE6810/APE6812)	V_{OH}	$1.8\text{V} < V_{CC} < V_{TH(\text{min})}$, $I_{\text{SOURCE}} = 500\mu\text{A}$	0.8 V_{CC}	-	-	V
		$1.2\text{V} < V_{CC} < 1.8\text{V}$, $I_{\text{SOURCE}} = 150\mu\text{A}$				
Hysteresis at V_{CC}	V_{Hys}	Input voltage	-	40	-	mV

PIN DESCRIPTIONS

PIN SYMBOL	PIN DESCRIPTION
VCC	Operating voltage input
GND	Ground
RESET/ $\overline{\text{RESET}}$	Reset output pin L: for APE6809/APE6811 H: for APE6810/APE6812

BLOCK DIAGRAM

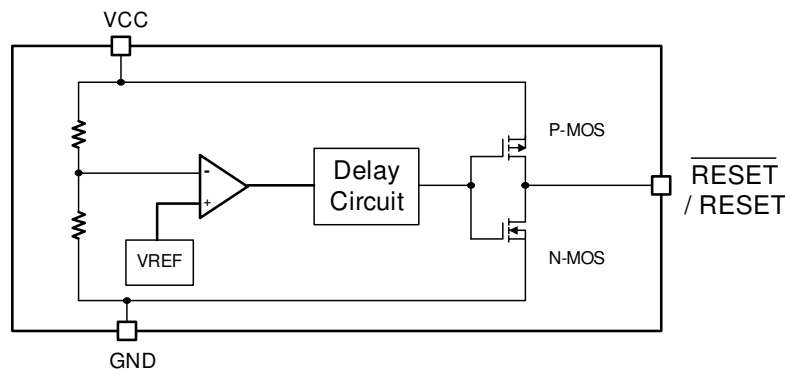

FUNCTION DESCRIPTION

A microprocessor's (μP 's) reset input starts the μP in a known state. The APE6809_6812 asserts reset to prevent code-execution errors during power-up, power-down, or brownout conditions. They assert a reset signal whenever the VCC supply voltage declines below a preset threshold, keeping it asserted for at least 200ms after VCC has risen above the reset threshold. The APE6809_6812 has a push-pull output stage.

APPLICATION INFORMATION

Negative-Going VCC Transients

In addition to issuing a reset to the μP during power-up, power-down, and brownout conditions, the APE6809_6812 is relatively immune to short-duration negative-going VCC transients (glitches).

The APE6809_6812 does not generate a reset pulse. The graph was generated using a negative going pulse applied to VCC, starting 0.5V above the actual reset threshold and ending below it by the magnitude indicated (reset comparator overdrive). The graph indicates the maximum pulse width a negative going VCC transient can have without causing a reset pulse. As the magnitude of the transient increases (goes farther below the reset threshold), the maximum allowable pulse width decreases. Typically, a VCC transient that goes 50mV below the reset threshold A 0.1 μF bypass capacitor mounted as close as possible to the VCC pin provides additional transient immunity.



APPLICATION INFORMATION

Ensuring a Valid Reset Output Down to VCC = 0

RESET is guaranteed to be a logic low for $VCC > 1.0V$. Once VCC exceeds the reset threshold, an internal timer keeps RESET low for the reset timeout period; after this interval, RESET goes high. If a brownout condition occurs (VCC dips below the reset threshold), RESET goes low. Any time VCC goes below the reset threshold, the internal timer resets to zero, and RESET goes low. The internal timer starts after VCC returns above the reset threshold, and RESET remains low for the reset timeout period.

When VCC falls below 1.0V, the APE6809/APE6811 RESET output no longer sinks current—it becomes an open circuit. Therefore, high-impedance CMOS logic inputs connected to RESET can drift to undetermined voltages.

This presents no problem in most applications since most μP and other circuitry is inoperative with VCC below 1.0V. However, in applications where RESET must be valid down to 0V, adding a pull down resistor to causes any stray leakage currents to flow to ground, holding RESET low. R1's value is not critical; 100k is large enough not to load RESET and small enough to pull RESET to ground. For the APE6810/APE6812 if RESET is required to remain valid for $VCC < 1.0V$.

Ensuring a Valid Reset Output Down to VCC = 0

Most μP supervisor ICs has reset threshold voltages between 5% and 10% below the value of nominal supply voltages. This ensures a reset will not occur within 5% of the nominal supply, but will occur when the supply is 10% below nominal. When using ICs rated at only the nominal supply $\pm 5\%$, this leaves a zone of uncertainty where the supply is between 5% and 10% low, and where the reset may or may not be asserted.



TYPICAL PERFORMANCE CHARACTERISTICS

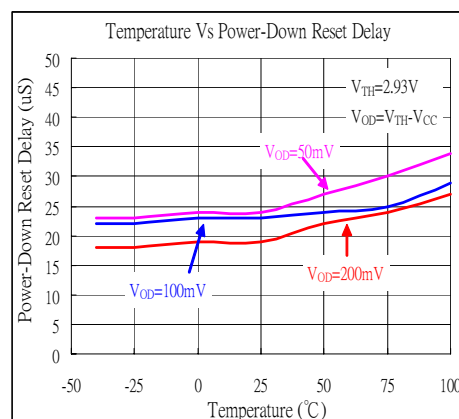
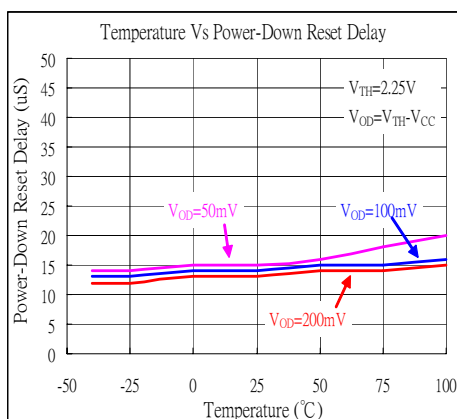
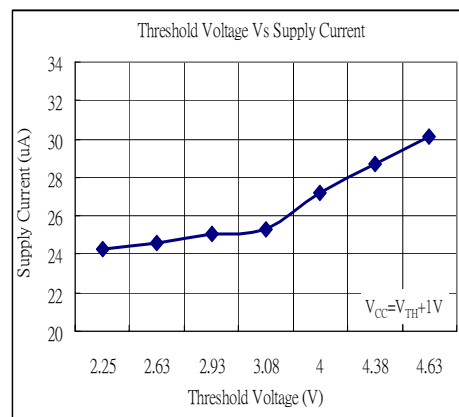
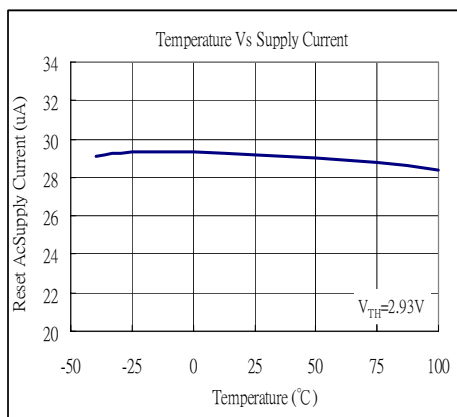
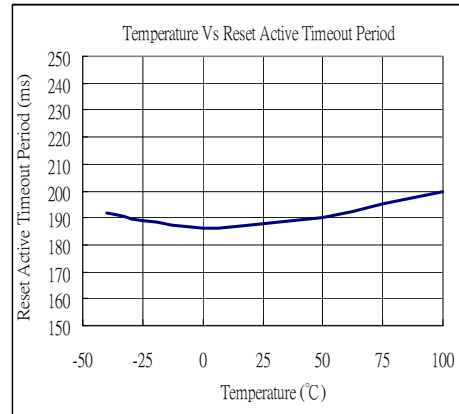
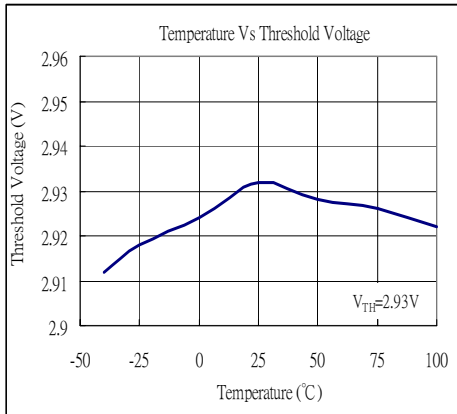



TYPICAL PERFORMANCE CHARACTERISTICS

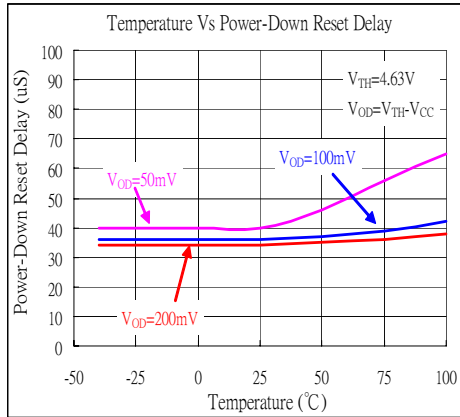

TIMING DIAGRAM

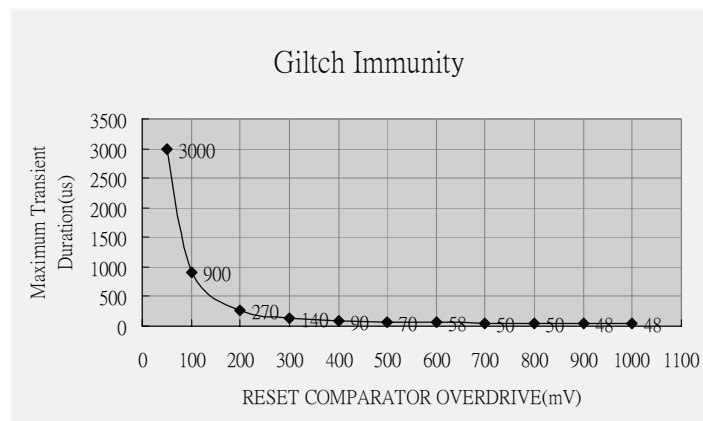
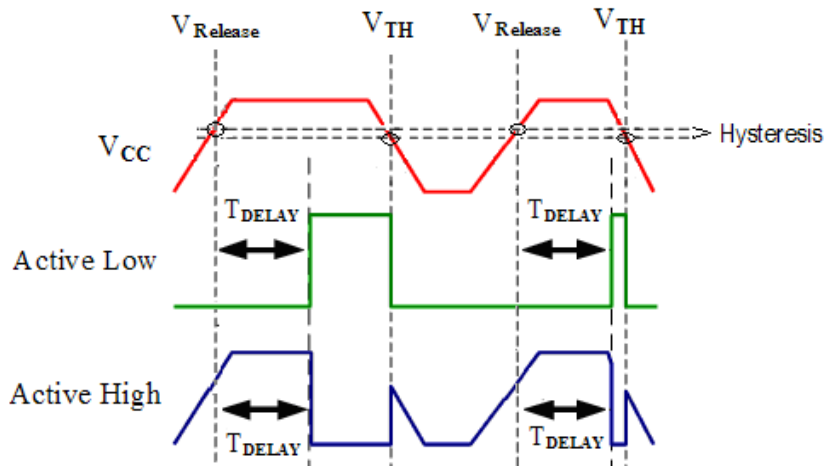



PACKAGE OUTLINE

(1) Package Type: SOT-23

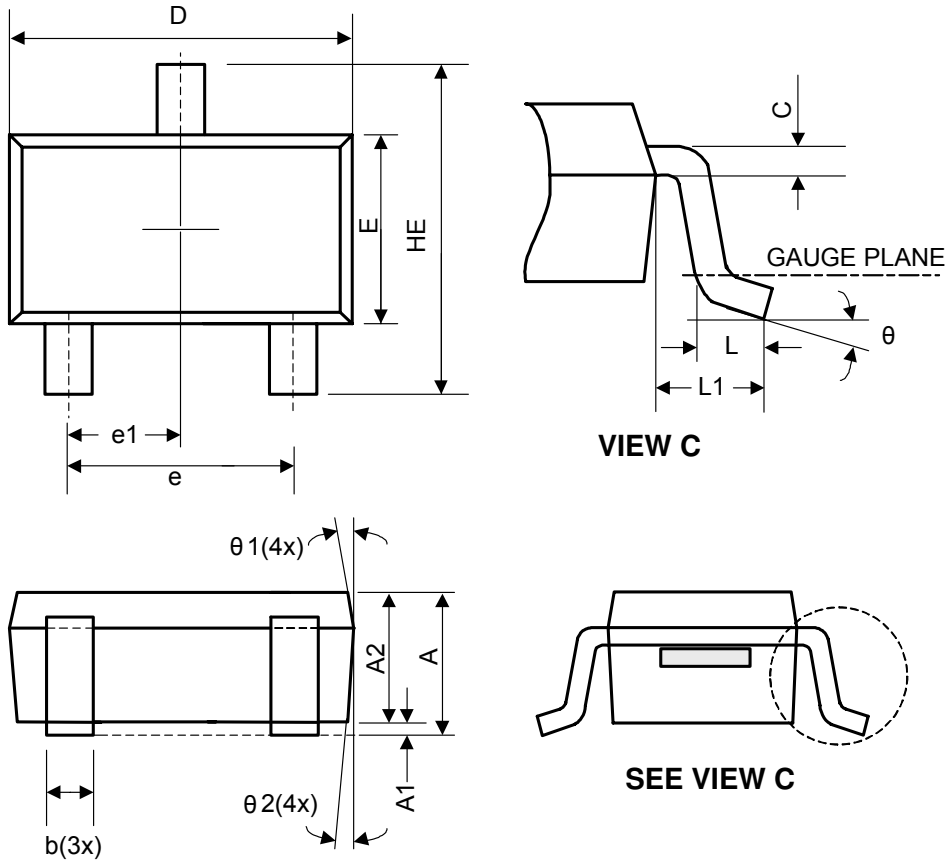

Symbol	Dimensions In Millimeters			Dimensions In Inches		
	Min.	Nom.		Min.	Nom.	
A	1.05	-	A	1.05	-	A
A1	0.05	-	A1	0.05	-	A1
A2	1.00	1.10	A2	1.00	1.10	A2
b	0.25	-	b	0.25	-	b
C	0.08	-	C	0.08	-	C
D	2.70	2.90	D	2.70	2.90	D
E	1.50	1.60	E	1.50	1.60	E
HE	2.60	2.80	HE	2.60	2.80	HE
L	0.30	-	L	0.30	-	L
L1	0.50	0.60	L1	0.50	0.60	L1
e	1.80	1.90	e	1.80	1.90	e
e1	0.85	0.95	e1	0.85	0.95	e1
theta	0°	5°	theta	0°	5°	theta
theta1	3°	5°	theta1	3°	5°	theta1
theta2	6°	8°	theta2	6°	8°	theta2



(2) Package Type: SC-70

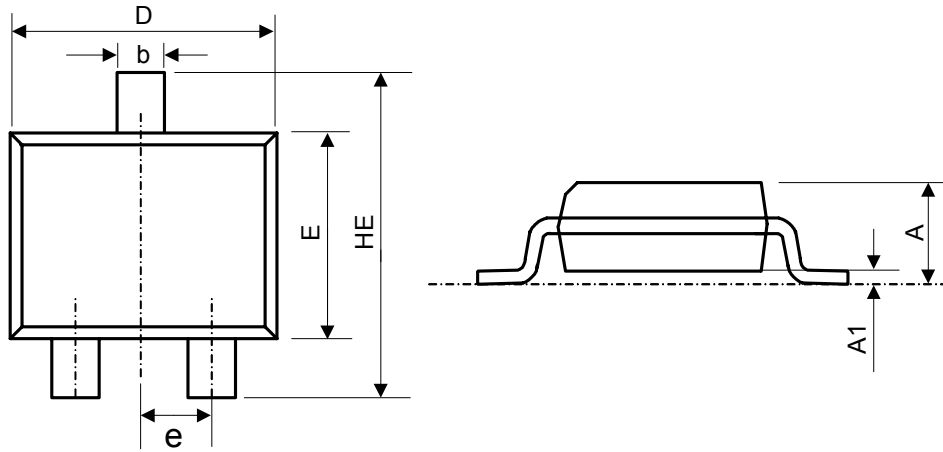

Symbol	Dimensions In Millimeters			Dimensions In Inches		
	Min.	Nom.	Max.	Min.	Nom.	Max.
A	0.80	0.95	1.10	0.032	0.039	0.043
A1	0.02	0.06	0.10	0.001	0.0025	0.004
D	1.80	2.00	2.20	0.070	0.079	0.087
HE	1.80	2.20	2.40	0.070	0.087	0.094
E	1.15	1.25	1.35	0.045	0.049	0.053
b	0.20	0.30	0.40	0.008	0.012	0.016
e	0.65 Bsc.			0.026 Bsc.		