

General Description

The AAT2861 is a highly integrated charge pump-based lighting management unit (LMU) offering eight LED channels with three linear regulators optimized for single-cell lithium-ion/polymer systems. The charge pump provides power for all LED outputs; multiple backlight and flash LED configurations are available. The backlight LED outputs can be programmed up to 31mA each and the flash LED output current can be programmed up to 600mA total. AnalogicTech's AS²Cwire™ (Advanced Simple Serial Control™) single-wire interface is used to enable, disable, and set the current to one of 32 levels for the backlight and one of 16 levels for the flash. A programmable safety timer and separate flash control input are included for easy flash control. Backlight current matching is better than 3% for uniform display brightness, and flash current matching is better than 5% for uniform power dissipation.

The AAT2861 also offers three high-performance low-noise MicroPower™ LDO linear regulators. The regulators output voltages are set through the AS²Cwire serial interface. Each LDO can supply up to 300mA load current and ground-pin current is only 80µA, making the AAT2861 ideal for battery-operated applications.

The AAT2861 is available in a Pb-free, space-saving TQFN34-24 package and operates over the -40°C to +85°C ambient temperature range.

Features

- Input Voltage Range: 2.7V to 5.5V
- AS²Cwire Serial Interface
- Tri-Mode Charge Pump
 - Drives up to Eight LEDs (Backlight/Flash)
- Programmable Backlight Current Settings
 - 31mA Maximum Current per Channel
 - 32 Linear Current Settings
 - Independent Main/Sub Settings
 - Programmable Fade-In and Fade-Out
- Programmable Flash Current
 - 600mA Total Flash Current
 - 16 Linear Current Settings
 - 1- or 2-Channel Configuration
- 1MHz Switching Frequency
- Automatic Soft-Start
- Three Linear Low Dropout Regulators
 - 300mA Output Current
 - 150mV Dropout
 - Programmable Output Voltage from 1.2V to 3.3V
 - Output Auto-Discharge for Fast Shutdown
- Built-In Thermal Protection
- Automatic Soft Start
- -40°C to +85°C Temperature Range
- TQFN34-24 Package

Applications

- Camera Enabled Mobile Devices
- Digital Still Cameras
- Multimedia Mobile Phones

Typical Application

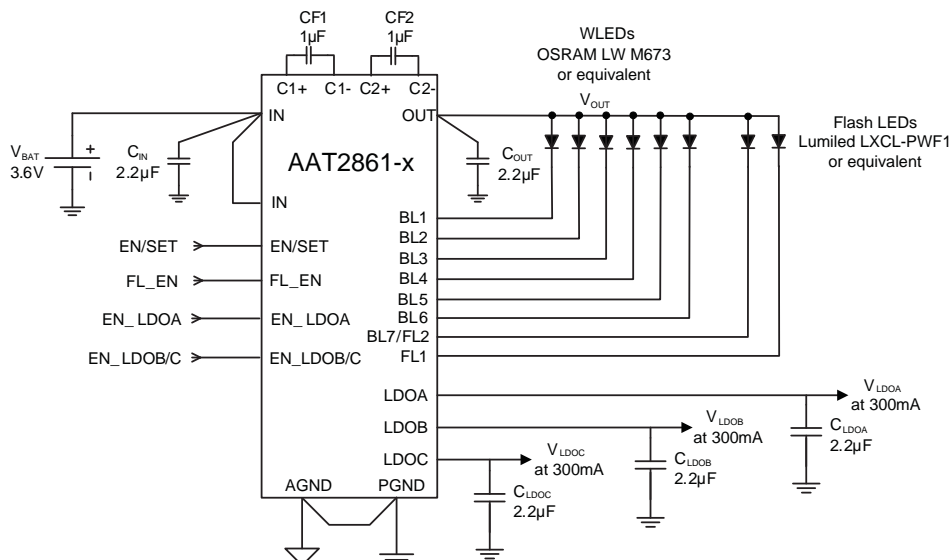

Pin Descriptions

Pin #	Symbol	Description
1	OUT	Charge pump output. OUT is the output of the charge pump and supplies current to the backlight and flash LEDs. Connect the backlight and flash LED anodes to OUT. Bypass OUT to PGND with a 2.2µF or larger ceramic capacitor as close to the AAT2861 as possible.
2	C2+	Positive terminal of charge pump capacitor 2. Connect the 1µF charge pump capacitor 2 from C2+ to C2-.
3	EN/SET	AS ² Cwire serial input. EN/SET is the address and data input of the AS ² Cwire serial interface. AS ² Cwire is used to control backlight, flash and LDO functions.
4	FL_EN	Flash enable. FL_EN is the enable control for the Flash LEDs. For the FL_EN pin to enable the flash current, the EN/SET pin must also be pulled high.
5	EN_LDOA	LDO A enable pin. EN_LDOA turns on or off LDO regulator A. The EN/SET pin must also be pulled high for LDO A to be enabled. The EN_LDOA input can be overwritten via the AS ² Cwire interface to disable LDO A.
6	EN_LDOB/C	LDO B and LDO C enable pin. EN_LDOB/C enables both LDO regulators B and C. The EN/SET pin must also be pulled high for the LDO regulators to be enabled. The EN_LDOB/C input can be overwritten via the AS ² Cwire interface to disable either LDO B or LDO C.
7	AGND	Analog ground. Connect AGND to PGND at a single point as close to the AAT2861 as possible.
8	LDOC	LDOC is the voltage output of LDO C. Bypass LDOC to AGND with a 2.2µF or larger capacitor as close to the AAT2861 as possible.
9	IN	Input power pin for all three LDOs. Connect Pin 9 to Pin 23 with as short a PCB trace as practical.
10	LDOB	LDOB is the voltage output of LDO B. Bypass LDOB to AGND with a 2.2µF or greater capacitor as close to the AAT2861 as possible.
11	LDOA	LDOA is the voltage output of LDO A. Bypass LDOA to AGND with a 2.2µF or larger ceramic capacitor as close to the AAT2861 as possible.
12	BL1	Backlight LED 1 current sink. BL1 controls the current through backlight LED 1. Connect the cathode of backlight LED 1 to BL1. If not used, connect BL1 to OUT.
13	BL2	Backlight LED 2 current sink. BL2 controls the current through backlight LED 2. Connect the cathode of backlight LED 2 to BL2. If not used, connect BL2 to OUT.
14	BL3	Backlight LED 3 current sink. BL3 controls the current through backlight LED 3. Connect the cathode of backlight LED 3 to BL3. If not used, connect BL3 to OUT.
15	BL4	Backlight LED 4 current sink. BL4 controls the current through backlight LED 4. Connect the cathode of backlight LED 4 to BL4. If not used, connect BL4 to OUT.
16	BL5	Backlight LED 5 current sink. BL5 controls the current through backlight LED 5. Connect the cathode of backlight LED 5 to BL5. If not used, connect BL5 to OUT.
17	BL6	Backlight LED 6 current sink. BL6 controls the current through backlight LED 6. Connect the cathode of backlight LED 6 to BL6. If not used, connect BL6 to OUT.
18	BL7 (FL2)	AAT2861-1/3: Backlight LED 7 current sink. BL7 controls the current through backlight LED 7. Connect the cathode of backlight LED 7 to BL7. If not used, connect BL7 to OUT. AAT2861-2: Flash LED 2 current sink. FL2 controls the current through Flash LED 2. Connect the cathode of Flash LED 2 to FL2. If not used, connect FL2 to OUT.
19	FL1	Flash LED 1 current sink. FL1 controls the current through Flash LED 1. Connect the cathode of Flash LED 1 to FL1. If not used, connect FL1 to OUT.
20	PGND	Power ground. Connect PGND to AGND at a single point as close to the AAT2861 as possible.
21	C2-	Negative terminal of charge pump capacitor 2.
22	C1-	Negative terminal of charge pump capacitor 1.
23	IN	Power input. Connect IN to the input source voltage. Bypass IN to PGND with a 2.2µF or larger ceramic capacitor as close to the AAT2861 as possible.
24	C1+	Positive terminal of charge pump capacitor 1. Connect the 1µF charge pump capacitor 1 from C1+ to C1-.
EP		Exposed paddle (bottom) Connect to PGND/AGND.

Pin Configuration

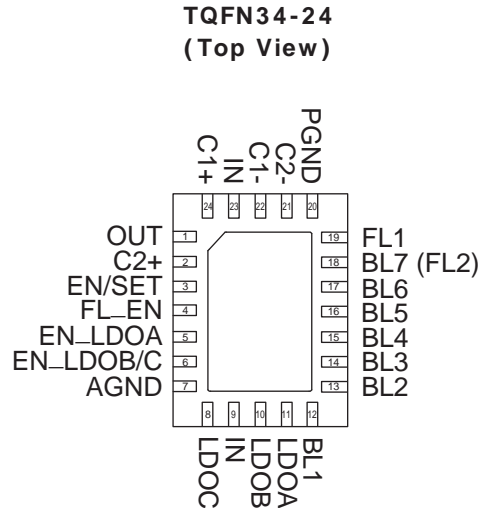

Part Number Descriptions¹

Part Number	Backlight LED Outputs		Flash LED Outputs
	Main	Sub	
AAT2861IMK-1-T1	4	3	1
AAT2861IMK-2-T1	4	2	2
AAT2861IMK-3-T1	5	2	1

Absolute Maximum Ratings²

Symbol	Description	Value	Units
	IN, OUT, BL1, BL2, BL3, BL4, BL5, BL6, BL7/FL2, FL1 Voltage to AGND	-0.3 to 6.0	V
	C1+, C2+ Voltage to AGND	-0.3 to $V_{OUT} + 0.3$	V
	C1-, C2-, LDOA, LDOB, LDOC, EN/SET, FL_EN, EN_LDOA, EN_LDOB/C Voltage to AGND	-0.3 to $V_{IN} + 0.3$	V
	PGND Voltage to AGND	-0.3 to 0.3	V
T_J	Operating Junction Temperature Range	-40 to 150	°C
T_{LEAD}	Maximum Soldering Temperature (at leads, 10 sec)	300	°C

Thermal Information^{3,4}

Symbol	Description	Value	Units
P_D	Maximum Power Dissipation	2.0	W
θ_{JA}	Maximum Thermal Resistance	50	°C/W

- Backlight and Flash Configuration within a part number is configured through the AS²Cwire serial interface. For example, disabling the "Main Equals Sub" feature (Address 8, Data 5 - 8) in the AAT2861-1 will configure BL1-BL4 LED outputs as MAIN and BL5-BL7 outputs as SUB.
- Stresses above those listed in Absolute Maximum Ratings may cause permanent damage to the device. Functional operation at conditions other than the operating conditions specified is not implied. Only one Absolute Maximum Rating should be applied at any one time.
- Derate 20mW/°C above 25°C ambient temperature.
- Mounted on a FR4 circuit board.

ChargePump™ Backlight/Flash LED Driver and Multiple LDO Lighting Management Unit
Electrical Characteristics¹

$V_{IN} = 3.6V$; $C_{IN} = C_{OUT} = 2.2\mu F$; $C_1 = C_2 = 1\mu F$; $T_A = -40^\circ C$ to $+85^\circ C$, unless otherwise noted. Typical values are $T_A = 25^\circ C$.

Symbol	Description	Conditions	Min	Typ	Max	Units
V_{IN}	IN Operating Voltage Range		2.7		5.5	V
I_{IN}	IN Operating Current (1x mode, Main Channels enabled, IBLX not included)	EN/SET = IN, BL1-BL7 = IN, FL_EN = EN_LDOA = EN_LDOB/C = AGND			600	μA
	IN Operating Current (2x mode, Main Channels enabled, IBLX not included)	2X Mode; EN/SET = IN, FL_EN = EN_LDOA = EN_LDOB/C = AGND; BL1-BL7 = OPEN			5.5	mA
	IN Operating Current (LDOA, LDOB and LDOC enabled)	EN/SET = EN_LDOA = EN_LDOB/C = IN; FL_EN = AGND; ADDR = 3; DATA = 1; No Load			225	μA
	IN Operating Current (Only LDOA enabled)	EN/SET = EN_LDOA = IN; FL_EN = EN_LDOB/C = AGND; ADDR = 3; DATA = 1; No Load			80	μA
$I_{IN(SHDN)}$	IN Shutdown Current	EN/SET, FL_EN, EN_LDOA, EN_LDOB/C = AGND			1.0	μA
T_{SD}	Over-Temperature Shutdown Threshold			140		$^\circ C$
$T_{SD(HYS)}$	Over-Temperature Shutdown Hysteresis			15		$^\circ C$
Charge Pump Section						
V_{OUT}	OUT Output Voltage			5.2		V
$I_{OUT(MAX)}$	OUT Maximum Output Current	$V_{IN} = 3.0V$, $V_{OUT} = 4.0$		800		mA
$V_{IN(TH, BL)}$	BL1-BL7 Charge Pump Mode Transition Hysteresis	EN/SET = IN; $V_{IN} - V_F = 1V$; ADDR = 0, DATA = 16; ADDR = 3, DATA = 3; ADDR = 2, DATA = 12		0.3		V
$V_{IN(TH, FL)}$	FL1-FL2 Charge Pump Mode Transition Hysteresis	EN/SET = FL_EN = IN; $V_{IN} - V_F = 1V$; ADDR = 10, DATA = 1		1		V
f_{OSC}	Charge Pump Oscillator Frequency	$T_A = 25^\circ C$		1		MHz
$t_{CP(SS)}$	Charge Pump Soft-Start Time	$T_A = 25^\circ C$		100		μs
BL1-BL6, BL7/ FL2, FL1 LED Drivers						
I_{BLx}	BL1-BL7 Current Accuracy	EN/SET = IN; $V_{IN} - V_F = 1V$; ADDR = 0, DATA = 16; ADDR = 3, DATA = 3; ADDR = 2, DATA = 12	18	20	22	mA
I_{BL-x}	BL1-BL7 Current Accuracy	EN/SET = IN; $V_{IN} - V_F = 1V$; ADDR = 0, DATA = 16; ADDR = 3, DATA = 4; ADDR = 2, DATA = 14	1.6	2	2.4	mA
$\Delta I_{(BLx)}/I_{BL(AVG)}$	BL1-BL7 Current Matching ²	EN/SET = IN; $V_{IN} - V_F = 1V$; ADDR = 0, DATA = 16; ADDR = 3, DATA = 3; ADDR = 2, DATA = 12		3		%
$V_{BL-(TH)}$	BL1-BL7 Charge Pump Transition Threshold	EN/SET = IN; $V_{IN} - V_F = 1V$; ADDR=0, DATA = 16; ADDR = 3, DATA = 3; ADDR = 2, DATA = 12		0.2		V
t_{FADE}	BL1-BL7 Automatic Fade-In/Fade-Out Timer	EN/SET = IN; $V_{IN} - V_F = 1V$; ADDR = 0, DATA = 16; ADDR = 1, DATA = 1; ADDR = 2, DATA = 12; ADDR = 3, DATA = 3	0.75	1	1.25	s
$I_{FL[1]}$	FL1 Current Accuracy	EN/SET = FL_EN = IN; $V_{IN} - V_F = 1V$; ADDR = 10, DATA = 1	540	600	660	mA
$I_{FL[1](DATA13)}$	FL1 Current Accuracy	EN/SET = FL_EN = IN; $V_{IN} - V_F = 1V$; ADDR = 10, DATA = 13	108	120	132	mA
$\Delta I_{(FLx)}/I_{FL(AVG)}$	FL1-FL2 Current Matching (AAT2861-2 only)	EN/SET = FL_EN = IN; $V_{IN} - V_F = 1V$; ADDR = 10, DATA = 1		5		%
$V_{FL[1/2](TH)}$	FL1 Charge Pump Transition Threshold	EN/SET = FL_EN = IN; $V_{IN} - V_F = 1V$; ADDR = 10, DATA = 1		0.45		V
$\Delta t_{FL}/t_{FL-SET}$	Flash Safety Timer Period	EN/SET = FL_EN = IN; $V_{IN} - V_F = 1V$; ADDR = 11, DATA = 1	1.5	2	2.5	s

1. The AAT2861 is guaranteed to meet performance specifications over the $-40^\circ C$ to $+85^\circ C$ operating temperature range and is assured by design, characterization, and correlation with statistical process controls.
 2. Current matching is defined as the deviation of any sink current from the average of all active channels.

Electrical Characteristics (continued)¹

$V_{IN} = 3.6V$; $C_{IN} = C_{OUT} = 2.2\mu F$; $C_1 = C_2 = 1\mu F$; $T_A = -40^\circ C$ to $+85^\circ C$, unless otherwise noted. Typical values are $T_A = 25^\circ C$.

Symbol	Description	Conditions	Min	Typ	Max	Units
Linear Regulators						
$\frac{\Delta V_{LDO[A/B/C]}}{V_{LDO[A/B/C]}}$	LDOA, LDOB, LDOC Output Voltage Tolerance	$I_{LDO} = 1mA$ to $200mA$; $T_A = 25^\circ C$	-1.5		1.5	%
		$I_{LDO} = 1mA$ to $200mA$; $T_A = -40^\circ C$ to $+85^\circ C$	-3.0		3.0	%
$I_{LDO[A/B/C](MAX)}$	LDOA, LDOB, LDOC Load Current		200			mA
$V_{LDO[A/B/C](DO)}$	LDOA, LDOB, LDOC Dropout Voltage ²	$V_{LDO[A/B/C]} \geq 3.0V$; $I_{LDO} = 150mA$		75	150	mV
$\frac{\Delta V_{LDO}}{V_{LDO}} * \Delta V_{IN}$	LDOA, LDOB, LDOC Line Regulation	$V_{IN} = (V_{LDO[A/B/C]} + 1V)$ to $5V$		0.09		%/V
$PSRR_{[A/B/C]}$	LDOA, LDOB, LDOC Power Supply Rejection Ratio	$I_{LDO[A/B/C]} = 10mA$, $1kHz$		50		dB
$R_{OUT(DCHG)}$	LDOA, LDOB, LDOC Auto-Discharge Resistance			20		Ω
EN/ SET AS²Cwire and Logic Control						
V_{IH}	EN/SET, FL_EN, EN_LDOA, EN_LDOB/C Input High Threshold Voltage	$2.7V \leq V_{IN} \leq 5.5V$	1.4			V
V_{IL}	EN/SET, FL_EN, EN_LDOA, EN_LDOB/C Input Low Threshold Voltage	$2.7V \leq V_{IN} \leq 5.5V$			0.4	V
$I_{IN(LKG)}$	EN/SET, FL_EN, EN_LDOA, EN_LDOB/C Input Leakage Current	EN/SET = IN = 5V	-1		1	μA
$t_{EN/SET(OFF)}$	EN/SET Input OFF Timeout				500	μs
$t_{EN/SET(LAT)}$	EN/SET Input Latch Timeout				500	μs
$t_{EN/SET(LOW)}$	EN/SET Input LOW Time		0.3		75	μs
$t_{ENSET(H-MIN)}$	EN/SET Minimum High Time			50		ns
$t_{ENSET(H-MAX)}$	EN/SET Maximum High Time				75	μs

1. The AAT2861 is guaranteed to meet performance specifications over the $-40^\circ C$ to $+85^\circ C$ operating temperature range and is assured by design, characterization, and correlation with statistical process controls.

2. $V_{DO[A/B/C]}$ is defined as $V_{IN} - V_{LDO[A/B/C]}$ when $V_{LDO[A/B/C]}$ is 98% of nominal.

Typical Characteristics

Backlight Efficiency vs. Input Voltage

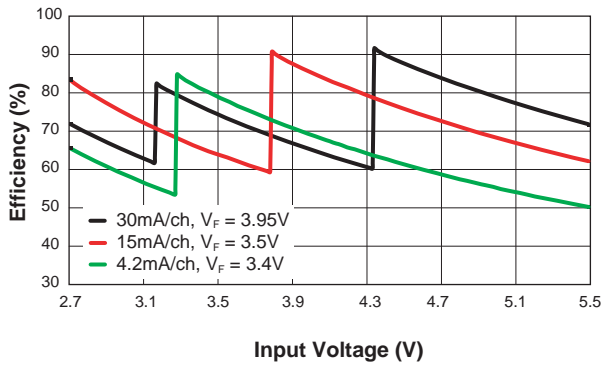

Flash Efficiency vs. Input Voltage

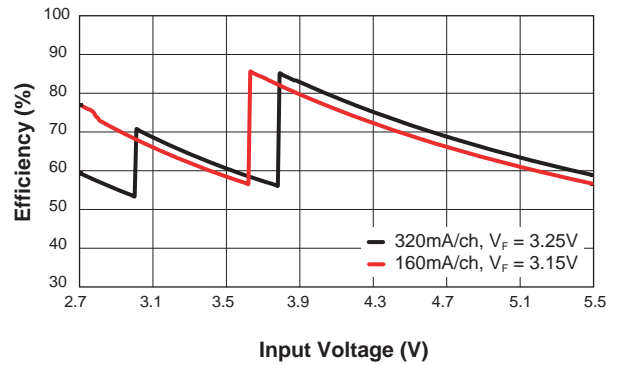

Backlight Current Matching vs. Temperature
($V_{IN} = 3.6V$; $20mA/ch$)

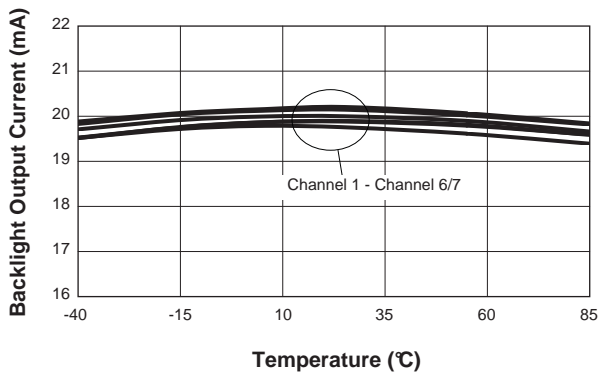

Charge Pump Output Turn On Characteristic
($V_{IN} = 3.6V$; $0mA/ch$; $C_{OUT} = 2.2\mu F$)

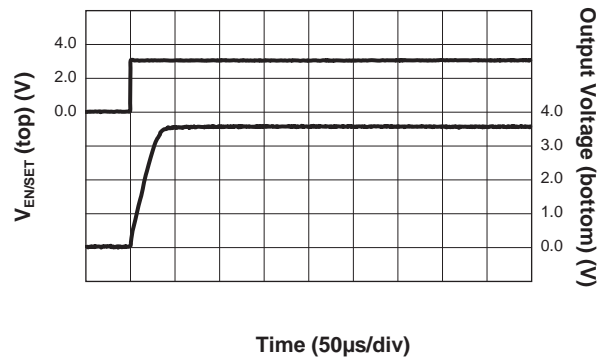

Turn On to 1X Mode Flash
($V_{IN} = 4.2V$; $300mA/ch$)

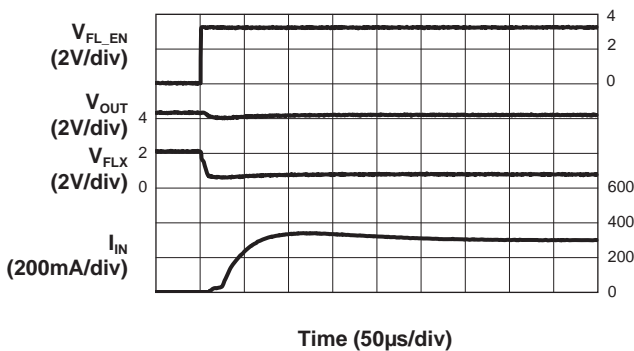

Turn On to 1.5X Mode Flash
($V_{IN} = 3.6V$; $300mA/ch$)

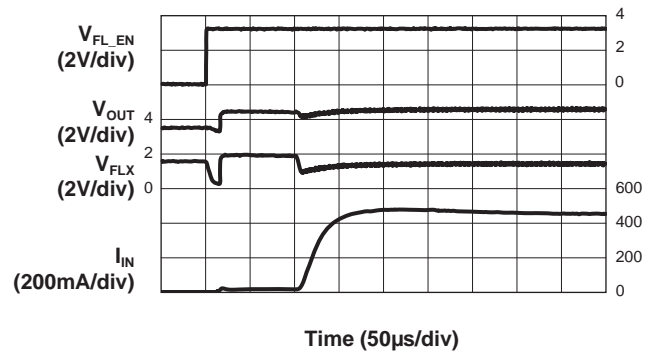

Typical Characteristics

Turn On to 2X Mode Flash
($V_{IN} = 2.8V$; 300mA/ch)

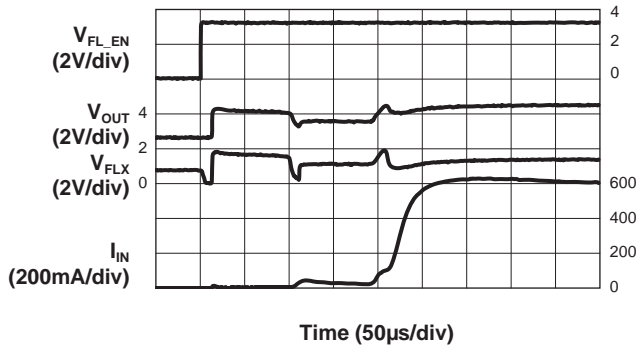

Turn On to 1X Mode Backlight
($V_{IN} = 3.6V$; 20mA/ch)

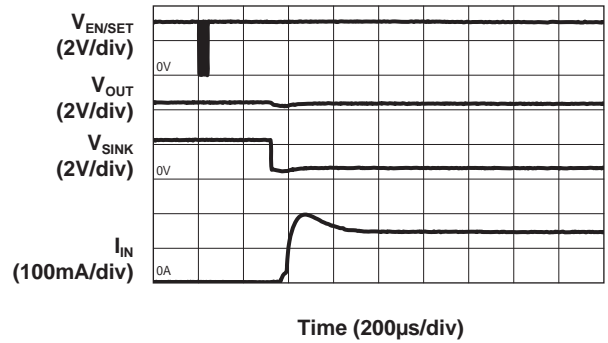

Turn On to 1.5X Mode Backlight
($V_{IN} = 3.2V$; 20mA/ch)

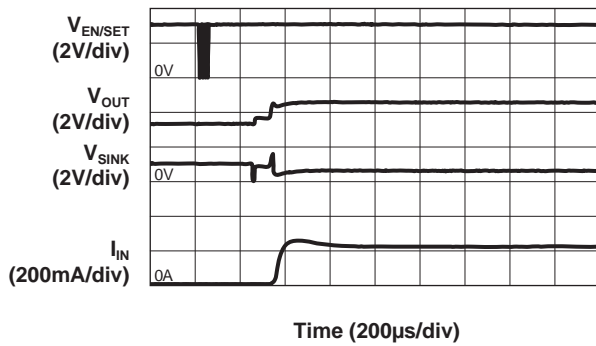

Turn On to 2X Mode Backlight
($V_{IN} = 3.0V$; 20mA/ch)

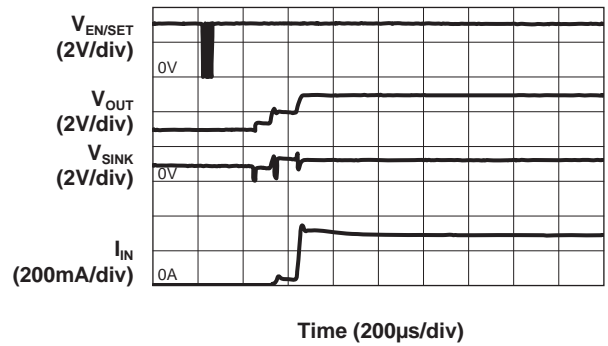

Turn Off from 1.5X Mode Backlight
($V_{IN} = 3.2V$; 20mA/ch)

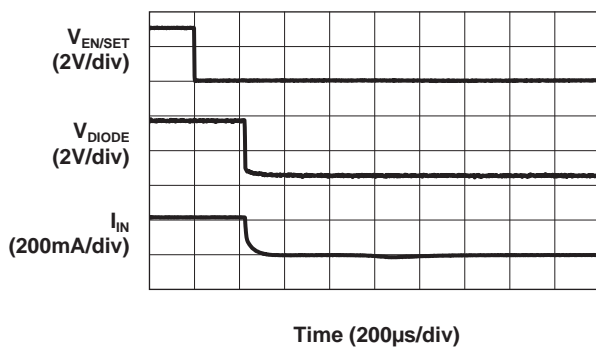

Operating Characteristic
($V_{IN} = 3.2V$; 20mA/ch Backlight; 1.5x Mode; $C_{OUT} = 2.2\mu F$)

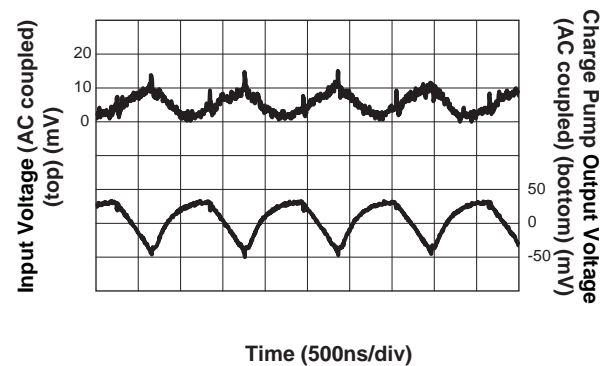

Typical Characteristics

Operating Characteristic

($V_{IN} = 3.0V$; 20mA/ch Backlight; 2X Mode; $C_{OUT} = 2.2\mu F$)

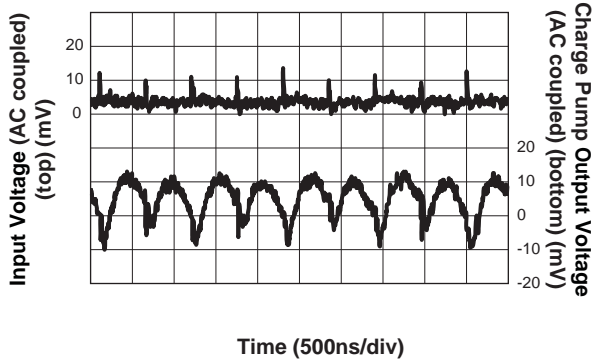

LDO A/B/C Load Regulation

($V_{IN} = 3.6V$)

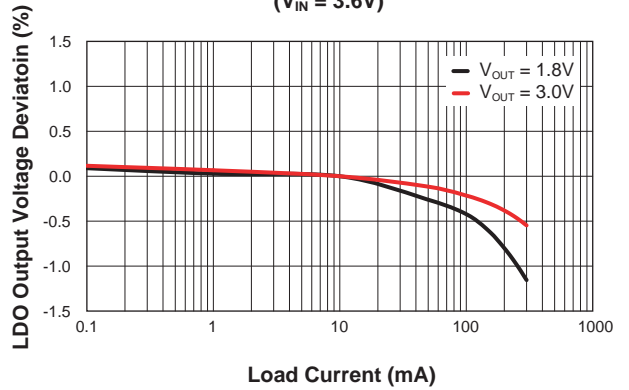

LDO A/B/C Output Voltage vs. Temperature

($V_{IN} = 3.6V$; $I_{LDO} = 0mA$)

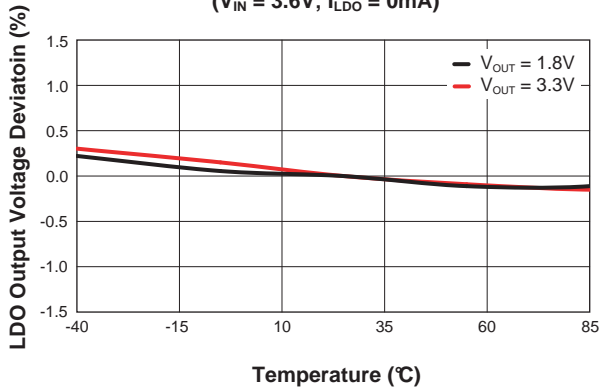

LDO A/B/C Load Transient Response

($I_{LDO} = 10mA$ to 200mA; $V_{IN} = 3.6V$; $V_{LDO} = 1.8V$; $C_{LDO} = 2.2\mu F$)

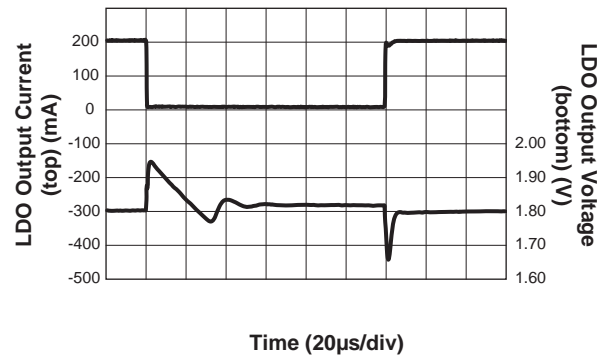

LDO A/B/C Line Transient Response

($V_{IN} = 3.6V$ to 4.2V; $I_{LDO} = 10mA$; $V_{OUT} = 1.8V$; $C_{LDO} = 2.2\mu F$)

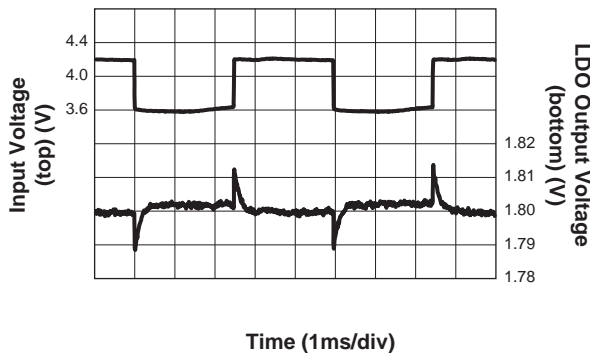

LDO A/B/C Turn On Characteristic

($V_{LDO} = 1.8V$; $V_{IN} = 3.6V$; $C_{LDO} = 2.2\mu F$)

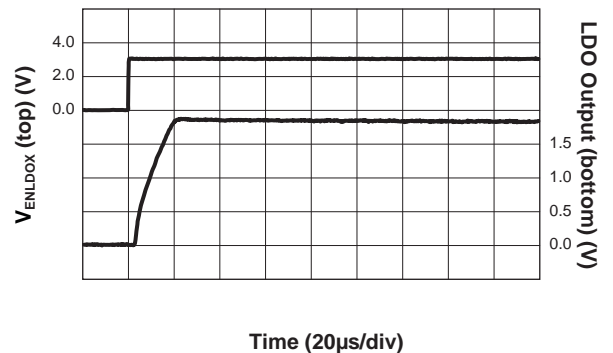

Typical Characteristics

**EN/SET, FL_EN, EN_LDOA, EN_LDOB/C
High Threshold Voltage vs. Input Voltage**

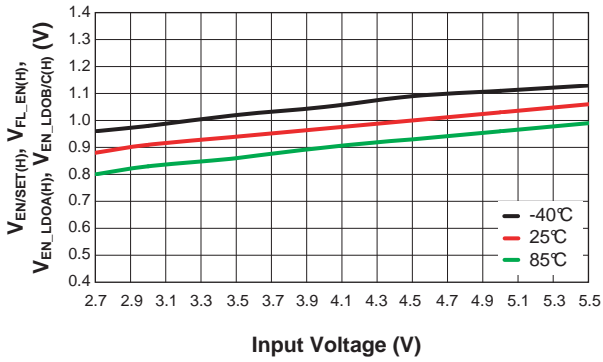

**EN/SET, FL_EN, EN_LDOA, EN_LDOB/C
Low Threshold Voltage vs. Input Voltage**

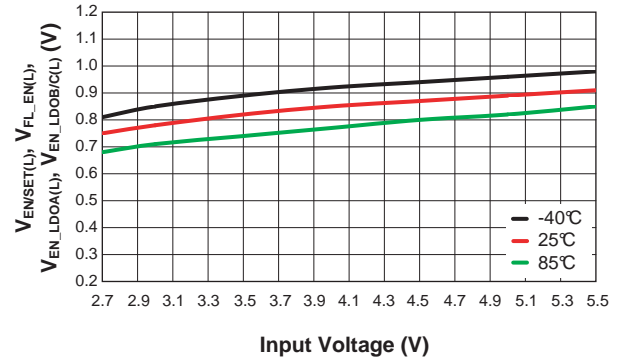

EN/SET Input Latch Timeout vs. Input Voltage

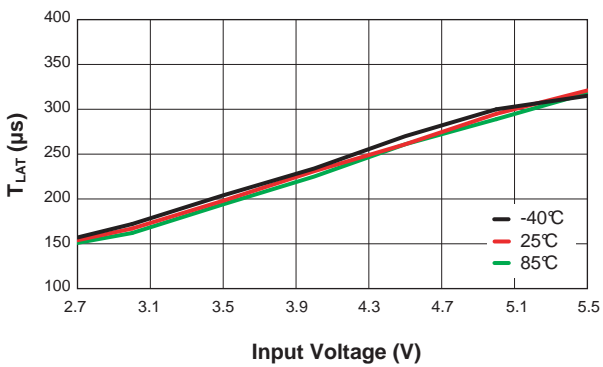

EN/SET Input Off Timeout vs. Input Voltage

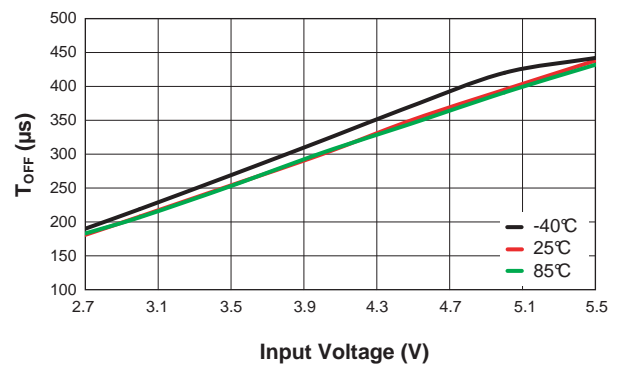

Functional Block Diagrams

AAT2861MK-1-T1

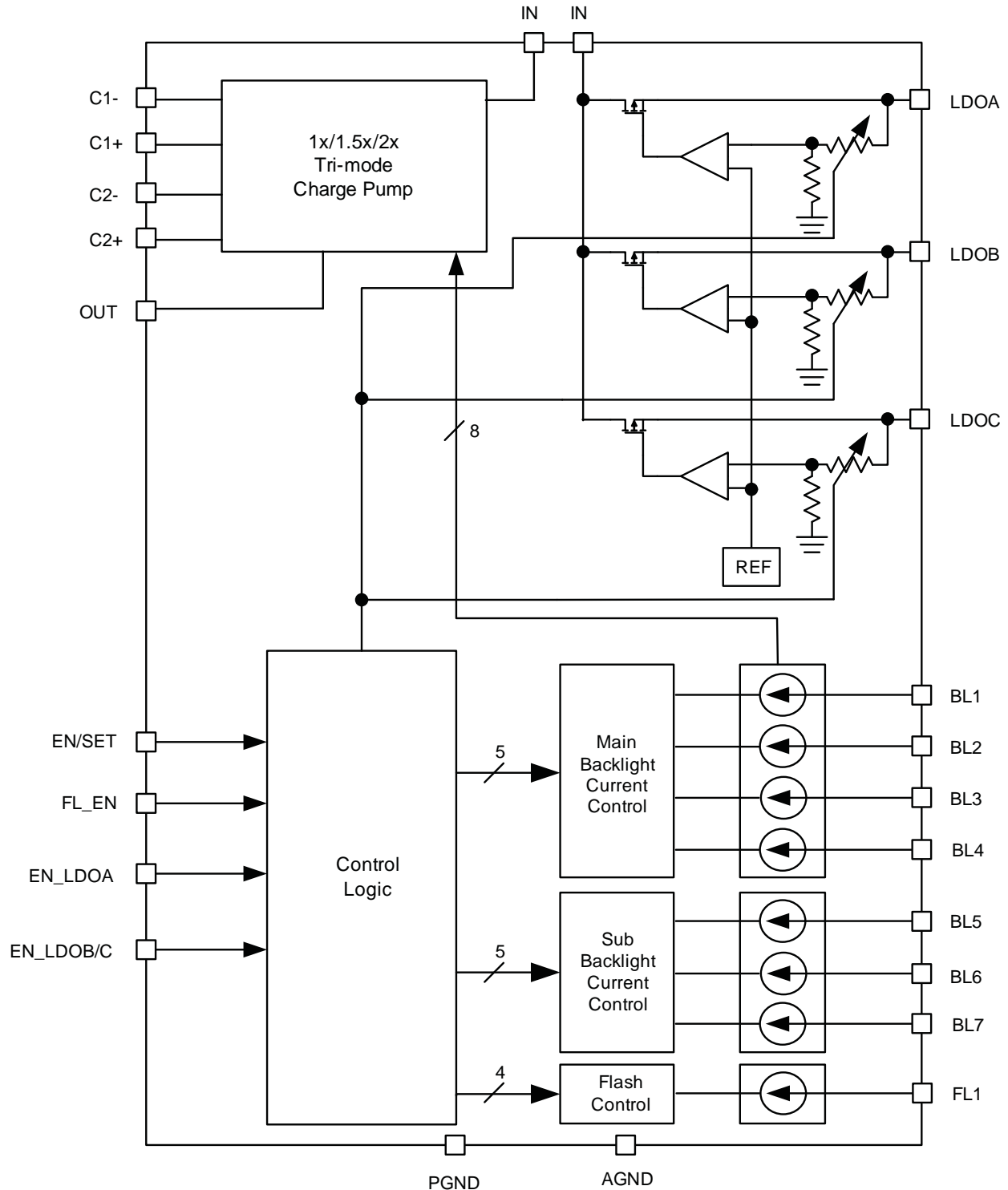

AAT2861IMK-2-T1

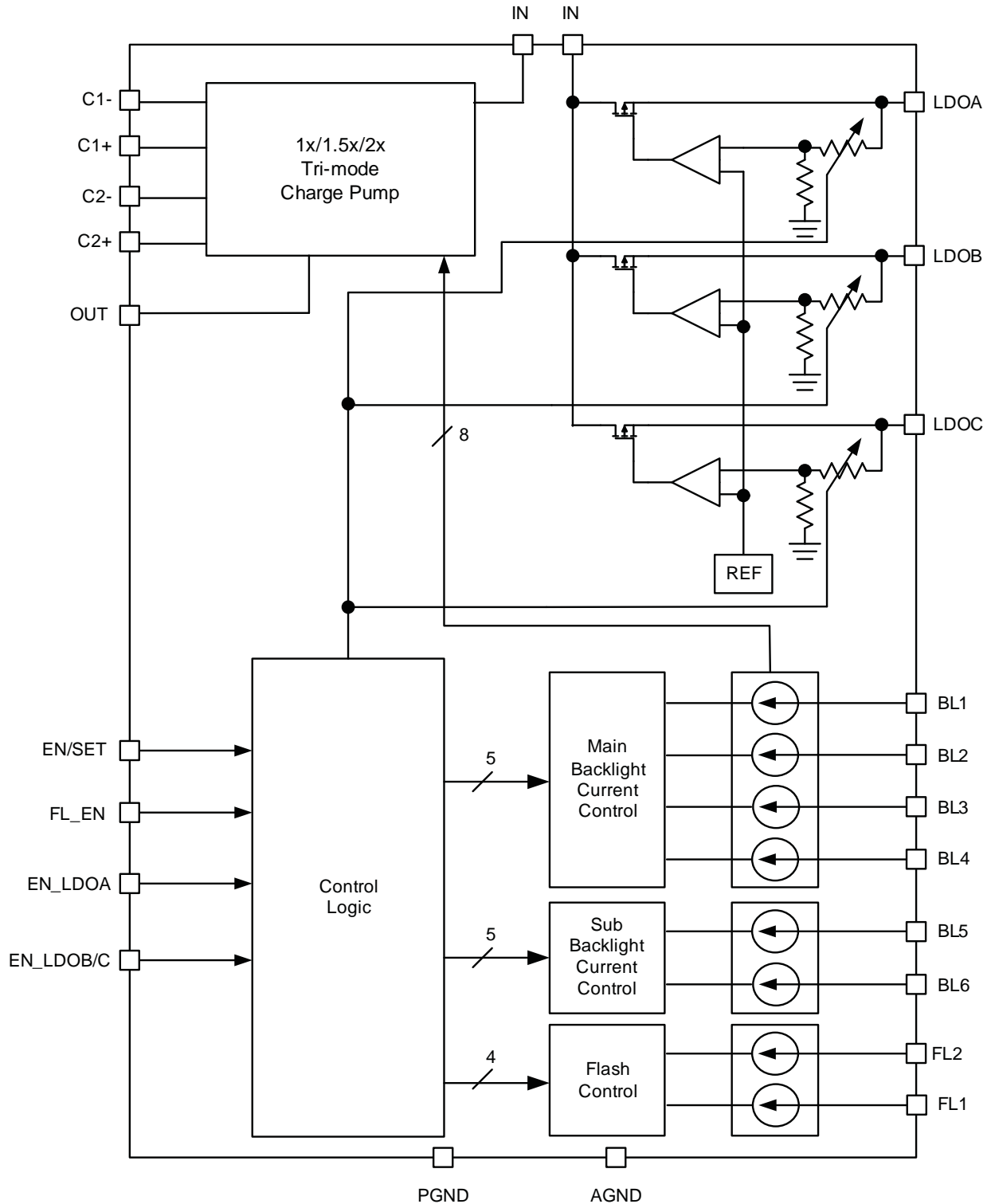

AAT2861IMK-3-T1

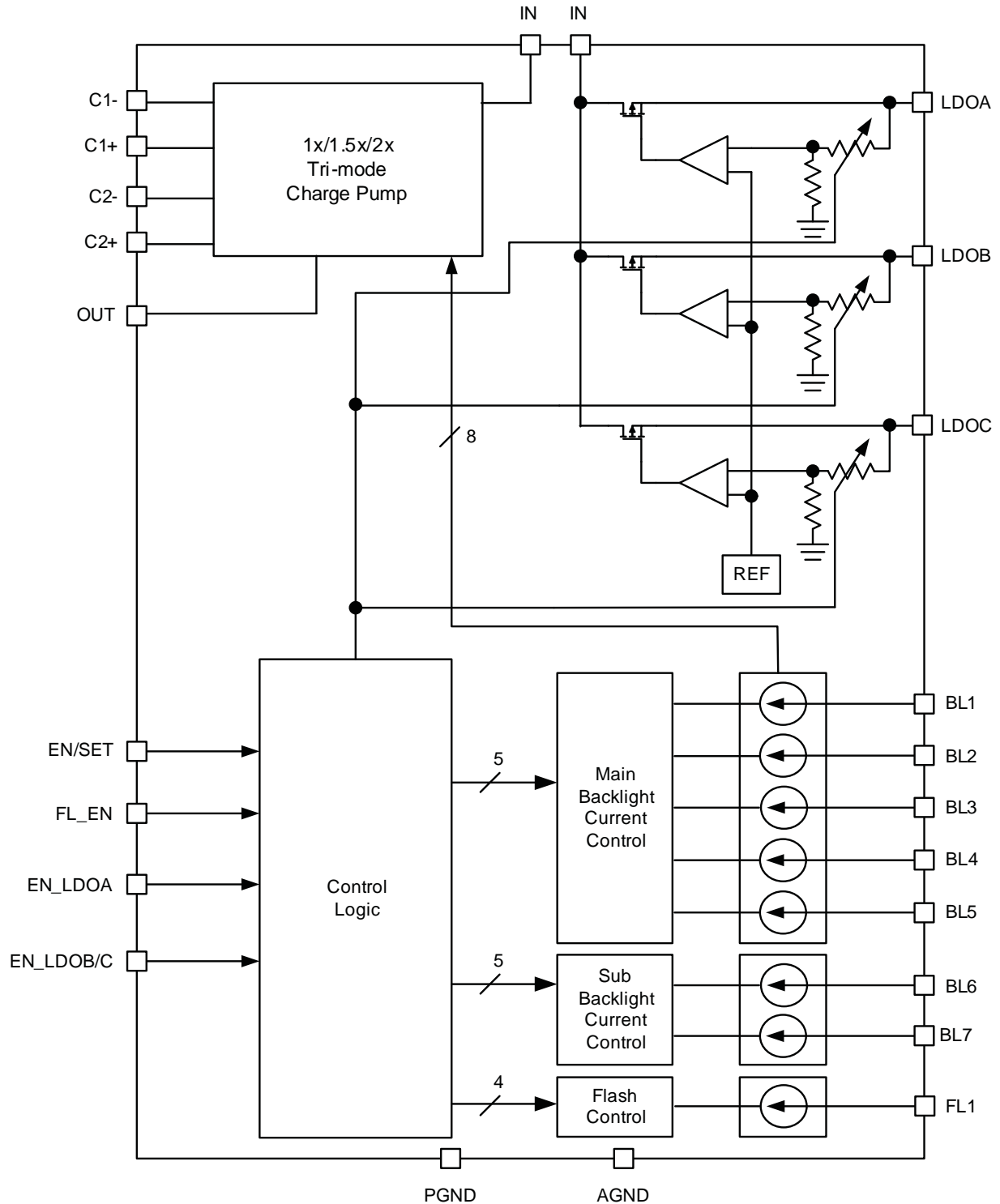

Functional Description

The AAT2861 is a highly integrated backlight and photo-flash driver family with three LDO regulators. The charge pump LED driver powers the backlight and flash LEDs from the 2.7V to 5.5V input voltage. The LDO regulators are powered from the same input and produce regulated output voltage between 1.2V and 3.3V. Control of the LEDs and the LDO output voltage is through an AS²Cwire serial interface for easy programming.

LED Drivers

The AAT2861 drives six or seven backlight LEDs up to 31mA each and a total of 600mA flash current through one or two channels. The LEDs are driven from a charge pump to insure that constant current is maintained over the entire battery voltage range. The charge pump automatically switches from 1X, to 1.5X, to 2X modes and back to maintain the LED current while minimizing power loss for high efficiency. The charge pump operates at the high 1MHz switching frequency, allowing the use of small 1 μ F ceramic capacitors.

Each individual LED is driven by a current sink to GND, allowing individual current control with high accuracy over a wide range of input voltages and LED forward voltages while maintaining high efficiency.

The charge pump is controlled by the voltage across the LED current sinks. When any one of the active backlight current sink/channel voltages drops below 200mV or the flash current sink/channel drops below 450mV, the charge pump goes to the next higher mode (from 1X to 1.5X or from 1.5X to 2X mode) to maintain sufficient LED voltage for constant LED current. The AAT2861 continuously monitors the LED forward voltages and uses the input voltage to determine when to reduce the charge pump mode for better efficiency. There is also a 300mV mode-transition hysteresis that prevents the charge pump from oscillating between modes.

LED Current Control

Both the backlight and flash LED currents are controlled through the AS²Cwire serial interface. The backlight LED current can be set between 0.5mA and 31mA in approx-

imately 1mA steps while the flash LED current can be set between 0 and 600mA in 40mA steps or 0 to 300mA in 20mA steps for two channel flash version. The backlight LED currents match to within 3% while the flash LED currents match to within 5%.

To eliminate the latency of the AS²Cwire serial interface, the flash LED is enabled through a dedicated input, FL_EN. The AAT2861 also includes a safety timer that prevents thermal overstress of the flash LED(s). This is important because many flash LEDs operate for a brief period beyond their steady-state operating limitations. If the flash driving hardware and/or software fail to turn the LED off, the safety timer insures that the LED or other circuitry is not damaged.

Both the backlight and flash LED currents are programmed through the AS²Cwire serial interface as are the backlight fade-in/fade-out timer and the flash safety timer. See the "AS²Cwire Serial Interface Programming" section of this datasheet for more information on setting the LED currents.

LDO Regulators

The AAT2861 includes three low dropout (LDO) linear regulators. These regulators are powered from the battery and produce a fixed output voltage set through the AS²Cwire serial interface. The output voltage can be set to one of 16 output voltages between 1.2V and 3.3V. The LDO regulators can be turned on/off with the external enable pins EN_LDOA and EN_LDOB/C. Additionally, the AS²Cwire interface allows the LDO regulators to be enabled independently when the EN_LDOA and EN_LDOB/C pins are pulled high.

The LDO regulators require only a small 2.2 μ F ceramic output capacitor for stability. If improved load transient response is required, larger-valued capacitors can be used without stability degradation.

AS²Cwire Serial Interface Protocol

The AAT2861 is dynamically programmable by the AS²Cwire single-wire interface. AS²Cwire records rising edges detected at the EN/SET pin to address and load the data registers. The timing diagram in Figure 1 shows the typical transmission protocol.

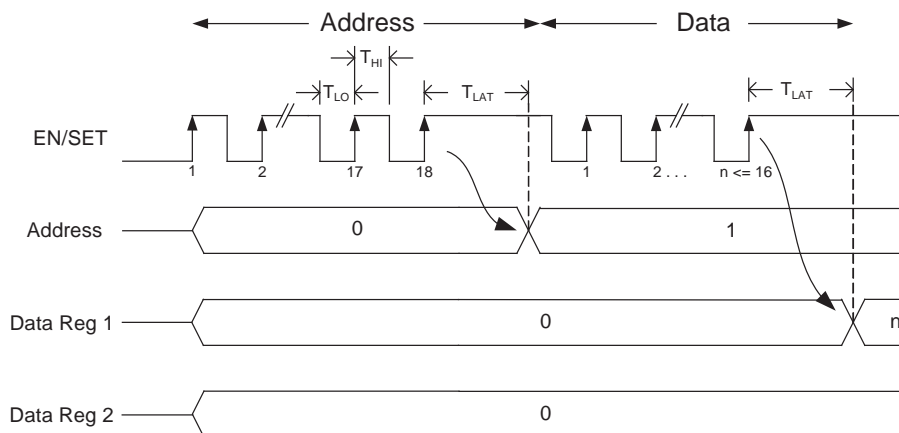

Figure 1: AS²Cwire Serial Interface Timing Diagram.

AS²Cwire latches data or address after the EN/SET input has been held high for time t_{LAT} (500 μ s). Address or data is differentiated by the number of EN/SET rising edges. Since the data registers are 4 bits each, the differentiating number of pulses is 2⁴ or 16, so that Address 0 is identified by 17 rising edges, Address 1 by 18 rising edges, Address 2 by 19 rising edges, etc. Data is set to any number of rising edges between 1 and 16. A typical write protocol is a burst of EN/SET rising edges identifying a particular address, followed by a pause with EN/SET held high for the t_{LAT} timeout period, then a burst of rising edges signifying data, and another t_{LAT} timeout after the data has been sent. Once an address is set, multiple writes to that address are allowed since the address is not reset after each write. Address edges are needed when changing the address, or writing to an address other than the default after shutdown. Address 0 is the default address after shutdown. If the part is enabled with only data edges and no address, then Address 0 will be programmed and LED Backlight channels BL1-BL7 will be enabled according to the number of data edges applied.

When EN/SET is held low for a time longer than t_{OFF} (500 μ s), the AAT2861 enters shutdown mode and draws less than 1 μ A of current from IN. At shutdown, the data and address registers are reset to 0.

AS²Cwire Serial Interface Programming

The AAT2861's AS²Cwire programmable Address registers are listed in Table 1. There are 14 Address registers, four registers control the three LDOs, six control the backlight LED configuration, two control the flash/lamp LED configuration and two are used to individually disable each backlight or flash channel.

Backlight Current Control (Address 0)

Address 0 controls the enabling of the Main and Sub channels. Table 2 shows the Data Codes used to control the Main and Sub Channels independently. The default condition for all backlight outputs (BL1-BL7) is OFF after power-up.

The AAT2861 family of LMUs also provides an internal LED current fade-in, fade-out feature. This feature is useful in those applications where it is preferred to turn on and off the backlight current using a smooth transition versus an abrupt transition. During the fade-in cycle, the LED current will be slowly increased to the programmed current level (set in Addresses 2 to 5). During the fade-out cycle, the LED current will be decreased linearly down to its programmed fade-out current threshold (set by Address 1) at which point the BL channels will be turned off. The fade-in and fade-out current is a linear transition over a time period of approximately 1 second.

The fade-in and fade-out function can be enabled and disabled independently for the Main and Sub groups by writing the desired Data to Address 0. Table 2 also lists the data codes used to program enable and disable the fade functions for the main and sub channels. If the "Main Equals Sub" feature (Address 3) is enabled (MEQS=1), the fade-in and fade-out settings for the Main and Sub channels are controlled by the "Main Fade" setting and the "Sub Fade" bit in Address 1 will be ignored.

At startup when the EN/SET pin is first pulled high, Address 0 is the default active register. The main and sub channels can be turned on by immediately writing data. For example, if Data = 4 is written the main and sub channels will turn on to the default value of 19mA.

Address	EN/ SET Rising Edges	Function	D3	D2	D1	D0
0	17	Backlight Main/Sub ON/OFF and Fade Enable	FADE_SUB	FADE_MAIN	SUB_ON	MAIN_ON
1	18	Backlight Fade Control	X	X	FLOOR[1]	FLOOR[0]
2	19	Backlight Current Main, LSB's	BLM[3]	BLM[2]	BLM[1]	BLM[0]
3	20	Backlight Current Main, MSB	Reserved	X	MEQS	BLM[4]
4	21	Backlight Current Sub, LSB's	BLS[3]	BLS[2]	BLS[1]	BLS[0]
5	22	Backlight Current Sub, MSB	X	X	X	BLS[4]
6	23	LDO Disable Control	X	OFF_LDOC	OFF_LDOB	OFF_LDOA
7	24	LDO A Output Voltage Control	LDOA[3]	LDOA[2]	LDOA[1]	LDOA[0]
8	25	LDO B Output Voltage Control	LDOB[3]	LDOB[2]	LDOB[1]	LDOB[0]
9	26	LDO C Output Voltage Control	LDOC[3]	LDOC[2]	LDOC[1]	LDOC[0]
10	27	Flash Current	F_HI[3]	F_HI[2]	F_HI[1]	F_HI[0]
11	28	Flash Timer Control	X	X	F_TIME[1]	F_TIME[0]
12	29	LED Channel Disable Control (BL1 – BL4)	OFF_BL4	OFF_BL3	OFF_BL2	OFF_BL1
13	30	LED Channel Disable Control (BL5, BL6, BL7/FL2, FL1)	OFF_FL1	OFF_BL7/FL2	OFF_BL6	OFF_BL5

Table 1: AAT2861- 1 Configuration/ Control Register Allocation

(* signifies that the data bit has a POR default bit value = 1; X signifies “Don’t care”).

Data	Sub Fade On	Main Fade On	Sub Channel	Main Channel
1*	No*	No*	Off*	Off*
2	No	No	Off	On
3	No	No	On	Off
4	No	No	On	On
5	No	Yes	Off	Off
6	No	Yes	Off	On
7	No	Yes	On	Off
8	No	Yes	On	On
9	Yes	No	Off	Off
10	Yes	No	Off	On
11	Yes	No	On	Off
12	Yes	No	On	On
13	Yes	Yes	Off	Off
14	Yes	Yes	Off	On
15	Yes	Yes	On	Off
16	Yes	Yes	On	On

Table 2: Backlight Main/ Sub ON/ OFF and Fade Enable (Address 0).

Backlight Fade-In and Fade-Out Control (Address 1)

During the fade-out cycle, the LED current will be decreased linearly down to its programmed fade-out

current threshold (set by Address 1) at which point the BL channels will be turned off. The default fade-out current level is 500µA, but can be changed to 1mA, 2mA or 3mA using the data codes listed in Table 3.

Data	Fade Out Current Level (mA)
1*	0.50*
2	1.0
3	2.0
4	3.0

Table 3: Backlight Fade-In and Fade-Out Control (Address 1).

Backlight Current Control (Addresses 2 to 5)

The AAT2861's AS²Cwire Addresses 2, 3, 4, and 5 control the backlight LED output current level in Main and Sub group of outputs. Address 2 and Address 3 control the Main backlight channel current to one of 32 levels according to Table 4 below. Address 3 acts as the MSB and Address 2 acts as the LSB for the current level setup. Address 4 and Address 5 control the Sub backlight channels current to one of 32 levels according to Table 5 below.

* Denotes the default (power-on-reset) value



ChargePump™ Backlight/Flash LED Driver and Multiple LDO Lighting Management Unit

Main Equals Sub OFF (MEQS= 0)					Main Equals Sub ON (MEQS= 1)				
Address	Data	Address	Data	Main Current	Address	Data	Address	Data	Main Current
3	1	2	1	31	3	3	2	1	31
3	1	2	2	30	3	3	2	2	30
3	1	2	3	29	3	3	2	3	29
3	1	2	4	28	3	3	2	4	28
3	1	2	5	27	3	3	2	5	27
3	1	2	6	26	3	3	2	6	26
3	1	2	7	25	3	3	2	7	25
3	1	2	8	24	3	3	2	8	24
3	1	2	9	23	3	3	2	9	23
3	1	2	10	22	3	3	2	10	22
3	1	2	11	21	3	3	2	11	21
3	1*	2	12*	20*	3	3	2	12	20
3	1	2	13	19	3	3	2	13	19
3	1	2	14	18	3	3	2	14	18
3	1	2	15	17	3	3	2	15	17
3	1	2	16	16	3	3	2	16	16
3	2	2	1	15	3	4	2	1	15
3	2	2	2	14	3	4	2	2	14
3	2	2	3	13	3	4	2	3	13
3	2	2	4	12	3	4	2	4	12
3	2	2	5	11	3	4	2	5	11
3	2	2	6	10	3	4	2	6	10
3	2	2	7	9	3	4	2	7	9
3	2	2	8	8	3	4	2	8	8
3	2	2	9	7	3	4	2	9	7
3	2	2	10	6	3	4	2	10	6
3	2	2	11	5	3	4	2	11	5
3	2	2	12	4	3	4	2	12	4
3	2	2	13	3	3	4	2	13	3
3	2	2	14	2	3	4	2	14	2
3	2	2	15	1	3	4	2	15	1
3	2	2	16	0.5	3	4	2	16	0.5

Table 4: Backlight Main Current Control (Addresses 2 and 3).

Sub Backlight				
Address	Data	Address	Data	Sub Current
5	1	4	1	31
5	1	4	2	30
5	1	4	3	29
5	1	4	4	28
5	1	4	5	27
5	1	4	6	26
5	1	4	7	25
5	1	4	8	24
5	1	4	9	23
5	1	4	10	22
5	1	4	11	21
5	1*	4	12*	20*
5	1	4	13	19
5	1	4	14	18
5	1	4	15	17
5	1	4	16	16
5	2	4	1	15
5	2	4	2	14
5	2	4	3	13
5	2	4	4	12
5	2	4	5	11
5	2	4	6	10
5	2	4	7	9
5	2	4	8	8
5	2	4	9	7
5	2	4	10	6
5	2	4	11	5
5	2	4	12	4
5	2	4	13	3
5	2	4	14	2
5	2	4	15	1
5	2	4	16	0.5

Table 5: Backlight Sub Current Control (Addresses 4 and 5).

The current settings for the Main and Sub channels are each divided into two Addresses. Any change in Data to the “Backlight Current Main (or Sub), LSB’s” Address will result in an immediate change to the LED current output level. Programming new current settings that require a change to both “Backlight Current Main (or Sub), MSB” and “Backlight Current Main (or Sub), LSB’s” Addresses could result in an errant intermediate current setting. To avoid this problem when the Data in “Backlight Current Main (or Sub), MSB” Address is changed the new current setting will not take effect until “Backlight Current Main (or Sub), LSB’s” Address has been written to and latched.

For example, a change from 28mA to 8mA in the Main backlight channels should follow this procedure. First, 28mA is set by programming Data = 3 to Address 2 and Data= 1 to Address 3. When changing to 8mA first write Data=2 to Address 3. The current level will not change after this step. Then write Data=7 to Address 2. After Address 2 has been latched the new 8mA current level will be set.

Address 3 also controls the “Main Equals Sub” feature in the AAT2861 products. This feature allows all backlight channels to be controlled with only the Main Channel current settings. If the “Main Equals Sub” feature is turned on (Data 3, or 4 in Address 3) the current settings of the Sub Channel are ignored. All backlight channels will be set to the same current levels as determined by the Data programmed to “Backlight Current Main” in Addresses 2 and 3. The Main and Sub channels are turned on and off by the “Main On” setting in Address 0. The default condition is for the “Main Equals Sub” feature to be turned OFF (MEQS= 0) after power-up.

Table 6 shows the Main and Sub Channel Configurations for the three versions of the AAT2861. The effect of the “Main Equals Sub” feature is clearly represented in this table.

Part Number	Main Equals Sub ($I_{MAIN} = I_{SUB}$)	
	Yes (Default)	No
AAT2861-1	7M+ 0S+ 1FL	4M+ 3S+ 1FL
AAT2861-2	6M+ 0S+ 2FL	4M+ 2S+ 2FL
AAT2861-3	7M+ 0S+ 1FL	5M+ 2S+ 1FL

Table 6: Main and Sub Channel Configurations.

LDO Output Voltage Control (Addresses 6 to 9)

The AAT2861’s three LDO regulators are configured by programming Addresses 6, 7, 8, and 9 via the AS²Cwire interface. With the EN/SET pin pulled high and the AAT2861 turned on, LDOA can be enabled using the EN_LDOA pin. LDOB and LDOC can be enabled together using the EN_LDOB/C pin. Additional LDO regulator control can be achieved using Address 6 to override the enable command of the EN_LDOA and EN_LDOB/C pins. For example, with the EN_LDOA and EN_LDOB/C pins enabled, writing Data 5 to Address 6 will disable LDOB and leave LDOA and LDOC enabled. Table 7 shows the LDO disable control.

Writing data to Addresses 7, 8, and 9 set the output voltages for LDOA, LDOB, and LDOC to one of 16 levels. The available LDO output voltages are shown in Table 8.

Data	LDO C	LDO B	LDO A
1*	Controlled by EN_LDOB/C*	Controlled by EN_LDOB/C*	Controlled by EN_LDOA*
2	Controlled by EN_LDOB/C	Controlled by EN_LDOB/C	OFF
3	Controlled by EN_LDOB/C	OFF	Controlled by EN_LDOA
4	Controlled by EN_LDOB/C	OFF	OFF
5	OFF	Controlled by EN_LDOB/C	Controlled by EN_LDOA
6	OFF	Controlled by EN_LDOB/C	OFF
7	OFF	OFF	Controlled by EN_LDOA
8	OFF	OFF	OFF

Table 7: LDO Disable Control (Address 6).

Data	V _{LDOA} (V)	V _{LDOB} (V)	V _{LDOC} (V)
1	1.2	1.2	1.2
2	1.3	1.3	1.3
3	1.5	1.5	1.5
4	1.6	1.6	1.6
5*	1.8*	1.8*	1.8*
6	2	2	2
7	2.2	2.2	2.2
8	2.5	2.5	2.5
9	2.6	2.6	2.6
10	2.7	2.7	2.7
11	2.8	2.8	2.8
12	2.9	2.9	2.9
13	3	3	3
14	3.1	3.1	3.1
15	3.2	3.2	3.2
16	3.3	3.3	3.3

Table 8: LDO X Output Voltage (Addresses 7, 8, and 9).

Fast turn-off response time is achieved by an active output pull-down circuit, which is enabled when the LDO regulator is disabled.

Flash Driver Control (Address 10 and 11)

The AAT2861-1 and AAT2861-3 are both configured with a single 600mA LED Flash channel, while the AAT2861-2 is configured with two LED Flash channels each capable of driving 300mA per channel. Address 10 programs the flash current level. Table 9 lists the data codes for the programming Address 10. Upon startup, the power-on-reset value in Address 10 is set to data code 13.

Data	Flash Current (mA) per Output	
	AAT2861-1 or -3	AAT2861-2
1	600	300
2	560	280
3	520	260
4	480	240
5	440	220
6	400	200
7	360	180
8	320	160
9	280	140
10	240	120
11	200	100
12	160	80
13*	120*	60*
14	80	40
15	40	20
16	OFF	OFF

Table 9: Flash Current Level (Address 10).

Once the EN/SET pin is pulled high and the AAT2861 has turned on, the LED Flash channels can be enabled by pulling the FL_EN to IN. The current setting of the LED Flash channels can be changed prior to enabling the flash current, or while the flash current is on.

The LED Flash controller also comes with a safety timer to prevent excessive heat generation and power loss from extended high current power dissipation. The LED flash safety timer duration can be set to four values by writing to Address 11. The default value at startup is 2 seconds. Table 10 shows the Data Codes for the flash safety timer.

* Denotes default (power-on-reset) value.

ChargePump™ Backlight/Flash LED Driver and Multiple LDO Lighting Management Unit

Torch/movie mode is automatically entered when the flash current setting is programmed to 120mA (60mA for channel for the AAT2861-2) or lower with Data = 13, 14, or 15. At these current levels the safety timer is automatically disabled and the flash channels will remain on as long as the FL_EN pin remains active. Extended duration flash use can be achieved for higher current settings by writing Data 4 to Address 11 to disable the safety timer. Though the AAT2861 includes an internal thermal limit circuit, be careful to limit the current setting (Address 10) to a value that will not generate excessive heat which may damage the flash LEDs or external circuitry.

Data	Flash Time (sec)
1*	2*
2	1
3	0.5
4	Always ON

Table 10: Flash Safety Timer (Address 11).
LED Channel Disable Control (Address 12 and 13)

Addresses 12 and 13 allow for additional programming flexibility by allowing each LED channel to be independently disabled. Normally, the backlight channels are controlled by MAIN_ON and SUB_ON controls in Address 0, while the FL_EN pin turns on the flash channels. Writing to Addresses 12 and 13 can override these controls to allow for any combination of LEDs to be turned on. The default state is for all LED channels to be "Conditionally ON" to allow the normal enable control.

In the following example we see how to turn on BL1, BL2, BL6, and BL7 in the AAT2861-1 (4M+ 3S+ 1FL). First write Address 12, Data= 13 and Address 13, Data= 10 to disable BL3, BL4, BL5, FL1. Then program the desired current setting using Addresses 2 through 5. Finally, write Address 0, Data= 4.

(NOTE: "Conditionally ON" state allows the LED channel to be turned ON but does not turn the channel ON. For BL1 to be enabled Data=2, 4, 6, 8... must be written to Address 0, and Data=1, 3, 5, 7... must be written to Address 12.)

Data	BL4	BL3	BL2	BL1
1*	Conditionally ON*	Conditionally ON*	Conditionally ON*	Conditionally ON*
2	Conditionally ON	Conditionally ON	Conditionally ON	OFF
3	Conditionally ON	Conditionally ON	OFF	Conditionally ON
4	Conditionally ON	Conditionally ON	OFF	OFF
5	Conditionally ON	OFF	Conditionally ON	Conditionally ON
6	Conditionally ON	OFF	Conditionally ON	OFF
7	Conditionally ON	OFF	OFF	Conditionally ON
8	Conditionally ON	OFF	OFF	OFF
9	OFF	Conditionally ON	Conditionally ON	Conditionally ON
10	OFF	Conditionally ON	Conditionally ON	OFF
11	OFF	Conditionally ON	OFF	Conditionally ON
12	OFF	Conditionally ON	OFF	OFF
13	OFF	OFF	Conditionally ON	Conditionally ON
14	OFF	OFF	Conditionally ON	OFF
15	OFF	OFF	OFF	Conditionally ON
16	OFF	OFF	OFF	OFF

Table 11: LED Channel Individual Disable Control, BL1-BL4 (Address 12).

* Denotes default (power-on-reset) value.

Data	FL1	BL7/ FL2	BL6	BL5
1*	Conditionally ON*	Conditionally ON *	Conditionally ON*	Conditionally ON*
2	Conditionally ON	Conditionally ON	Conditionally ON	OFF
3	Conditionally ON	Conditionally ON	OFF	Conditionally ON
4	Conditionally ON	Conditionally ON	OFF	OFF
5	Conditionally ON	OFF	Conditionally ON	Conditionally ON
6	Conditionally ON	OFF	Conditionally ON	OFF
7	Conditionally ON	OFF	OFF	Conditionally ON
8	Conditionally ON	OFF	OFF	OFF
9	OFF	Conditionally ON	Conditionally ON	Conditionally ON
10	OFF	Conditionally ON	Conditionally ON	OFF
11	OFF	Conditionally ON	OFF	Conditionally ON
12	OFF	Conditionally ON	OFF	OFF
13	OFF	OFF	Conditionally ON	Conditionally ON
14	OFF	OFF	Conditionally ON	OFF
15	OFF	OFF	OFF	Conditionally ON
16	OFF	OFF	OFF	OFF

Table 12: LED Channel Individual Disable Control, BL5, BL6, BL7/ FL2, FL1 (Address 13).

Applications Information

LED Selection

The AAT2861 is specifically intended for driving white LEDs. However, the device design will allow the AAT2861 to drive most types of LEDs with forward voltage specifications ranging from 2.0V to 4.7V. LED applications may include mixed arrangements for display backlighting, color (RGB) LEDs, infrared (IR) diodes and any other load needing a constant current source generated from a varying input voltage. Since the BL1 to BL6, BL7/ FL2 and FL1 constant current sinks are matched with negligible voltage dependence, the constant current channels will be matched regardless of the specific LED forward voltage (V_F) levels.

The low-dropout current sinks in the AAT2861 maximize performance and make it capable of driving LEDs with high forward voltages. Multiple channels can be combined to obtain a higher LED drive current without complication.

Device Switching Noise Performance

The AAT2861 operates at a fixed frequency of approximately 1MHz to control noise and limit harmonics that can interfere with the RF operation of cellular telephone handsets or other communication devices. Back-injected noise appearing on the input pin of the charge pump is 20mV peak-to-peak, typically ten times less than inductor-based DC/DC boost converter white LED backlight solutions. The AAT2861 soft-start feature prevents noise transient effects associated with in-rush currents during the start up of the charge pump circuit.

Device Power Efficiency

Charge-pump efficiency discussion in the following sections accounts only for the efficiency of the charge pump section itself. Due to the unique circuit architecture and design of the AAT2861, it is very difficult to measure efficiency in terms of a percent value comparing input power over output power.

* Denotes default (power-on-reset) value.

ChargePump™ Backlight/Flash LED Driver and Multiple LDO Lighting Management Unit

Since the AAT2861 outputs are pure constant current sinks and typically drive individual loads, it is difficult to measure the output voltage for a given output (BL1 to BL6, BL7/FL2, and FL1) to derive an overall output power measurement. For any given application, white LED forward voltage levels can differ, yet the output drive current will be maintained as a constant.

This makes quantifying output power a difficult task when taken in the context of comparing to other white LED driver circuit topologies. A better way to quantify total device efficiency is to observe the total input power to the device for a given LED current drive level. The best white LED driver for a given application should be based on trade-offs of size, external component count, reliability, operating range and total energy usage...*not just "% efficiency."*

The AAT2861 efficiency may be quantified under very specific conditions and is dependant upon the input voltage versus the output voltage seen across the loads applied to outputs BL1 through BL6, BL7/FL2 or FL1 for a given constant current setting. Depending on the combination of I_{IN} and voltages sensed at the current sinks, the device will operate in "Load Switch" (1X) mode. When any one of the voltages sensed at the current sinks nears dropout the device will operate in 1.5X or 2X charge pump mode. Each of these modes will yield different efficiency values. One should refer to the following two sections for explanations for each operational mode.

AAT2861 charge pump conversion efficiency is defined as the power delivered to the white LED load divided by the input power:

$$\eta = \frac{P_{LEDs}}{P_{IN}} = \frac{V_{LED1} \cdot I_{LED1} + \dots + V_{LEDX} \cdot I_{LEDX}}{V_{IN} \cdot I_{IN}}$$

V_{LEDX} = White LED Forward Voltage (V_F)

I_{LEDX} = White LED Bias Current (I_D)

X = Number of White LEDs

The expression to define the estimated ideal efficiency (η) for the AAT2861 in 1X mode is as follows:

$$\eta = \frac{P_{LEDs}}{P_{IN}} = \frac{X \cdot V_{LEDX} \cdot I_{LEDX}}{V_{IN} \cdot I_{IN}}$$

$$X = 1, 2, 3, \dots, 6 \text{ or } 7 \text{ and } I_{IN} = X \cdot I_{LEDX}$$

$$\eta = \frac{V_{LEDX}}{V_{IN}}$$

The AAT2861 charge pump is a fractional charge pump which will boost the input supply voltage in the event where I_{IN} is less than the required output voltage across the backlight white LED load. The efficiency can be simply defined as a linear voltage regulator with an effective white LED forward voltage that is equal to one and a half (1.5x mode) times the input voltage.

With an ideal 1.5x charge pump, the input current is 1.5x of the output current. The expression to define the estimated ideal efficiency (η) for the AAT2861 in 1.5x mode is as follows:

$$\eta = \frac{P_{LEDs}}{P_{IN}} = \frac{V_{LED1} \cdot I_{LED1} + \dots + V_{LEDX} \cdot I_{LEDX}}{V_{IN} \cdot I_{IN}}$$

$$\eta = \frac{X \cdot V_{LEDX} \cdot I_{LEDX}}{V_{IN} \cdot I_{IN}}; X = 1, 2, 3, \dots, 6 \text{ or } 7 \text{ and } I_{IN} = 1.5(X \cdot I_{LEDX})$$

$$\eta = \frac{V_{LEDX}}{1.5V_{IN}}$$

The same calculations apply for the AAT2861 in 2x mode where for an ideal 2x charge pump, the input current is 2x of the output current. The expression for the estimated ideal efficiency (η) for the AAT2861 in 2x mode is as follows:

$$\eta = \frac{P_{LEDs}}{P_{IN}} = \frac{V_{LED1} \cdot I_{LED1} + \dots + V_{LEDX} \cdot I_{LEDX}}{V_{IN} \cdot I_{IN}}$$

$$\eta = \frac{X \cdot V_{LEDX} \cdot I_{LEDX}}{V_{IN} \cdot I_{IN}}; X = 1, 2, 3, \dots, 6 \text{ or } 7 \text{ and } I_{IN} = 2(X \cdot I_{LEDX})$$

$$\eta = \frac{V_{LEDX}}{2V_{IN}}$$

In addition, with an ideal 1.5x charge pump, the output current may be expressed as 2/3 of the input current. For a charge pump with an output of 5V and a nominal input of 3.5V, the theoretical efficiency is 95%. Due to internal switching losses and IC quiescent current consumption, the actual efficiency can be measured at 93%. Efficiency will decrease substantially as load current drops below 1mA or when the level of I_{IN} approaches I_{OUT} . The same calculations apply for 2X mode where the output current then becomes 1/2 of the input current.

Capacitor Selection

Careful selection of all external capacitors C_{IN} , C_1 , C_2 , $C_{LDO(A/B/C)}$, and C_{OUT} is important because they will affect turn-on time, output ripple and transient performance. Optimum performance will be obtained when low ESR

ChargePump™ Backlight/Flash LED Driver and Multiple LDO Lighting Management Unit

ceramic capacitors are used. In general, low ESR may be defined as less than 100mΩ.

Ceramic composition capacitors are highly recommended over all other types of capacitors for use with the AAT2861. Ceramic capacitors offer many advantages over their tantalum and aluminum electrolytic counterparts. A ceramic capacitor typically has very low ESR, is lowest cost, has a smaller printed circuit board (PCB) footprint, and is non-polarized. Since ceramic capacitors are non-polarized, they are not prone to incorrect connection damage.

Equivalent Series Resistance (ESR)

ESR is an important characteristic to consider when selecting a capacitor. ESR is a resistance internal to a capacitor, which is caused by the leads, internal connections, size or area, material composition and ambient temperature. Capacitor ESR is typically measured in milliohms for ceramic capacitors and can range to more than several ohms for tantalum or aluminum electrolytic capacitors.

Ceramic Capacitor Materials

Ceramic capacitors less than 0.1µF are typically made from NPO or COG materials. NPO and COG materials typically have tight tolerance and are stable over temperature. Larger capacitor values are typically composed of X7R, X5R, Z5U or Y5V dielectric materials. Large ceramic capacitors, typically greater than 2.2µF are often available in low cost Y5V and Z5U dielectrics, but capacitors greater than 1µF are typically not required for AAT2861 applications.

Capacitor area is another contributor to ESR. Capacitors that are physically large will have a lower ESR when compared to an equivalent material smaller capacitor.

These larger size capacitors can improve circuit transient response when compared to an equal value capacitor in a smaller package size.

PCB Layout

To achieve adequate electrical and thermal performance, careful attention must be given to the PCB layout. In the worst-case operating condition, the chip must dissipate considerable power at full load. Adequate heat-sinking must be achieved to ensure intended operation.

Figures 2 and 3 illustrate an example PCB layout. The bottom of the package features an exposed metal paddle. The exposed paddle acts, thermally, to transfer heat from the chip and, electrically, as a ground connection.

The junction-to-ambient thermal resistance (θ_{JA}) for the connection can be significantly reduced by following a couple of important PCB design guidelines.

The PCB area directly underneath the package should be plated so that the exposed paddle can be mated to the top layer PCB copper during the re-flow process. Multiple copper plated thru-holes should be used to electrically and thermally connect the top surface paddle area to additional ground plane(s) and/or the bottom layer ground pour.

The chip ground is internally connected to both the paddle and to the AGND and PGND pins. It is good practice to connect the GND pins to the exposed paddle area with traces as shown in the example.

The flying capacitors C1 and C2 should be connected close to the IC. Trace length should be kept short to minimize path resistance and potential coupling. The input and output capacitors should also be placed as close to the chip as possible.

Manufacturer	Part Number	Value	Voltage	Temp. Co.	Case
AVX	0603ZD105K	1µF	10	X5R	0603
	0603ZD225K	2.2µF	10		
TDK	C1608X5R1E105K	1µF	25	X5R	0603
	C1608X5R1C225K	2.2µF	16		
	C1608X5R1A475K	4.7µF	10		
Murata	GRM188R61C105K	1µF	16	X5R	0603
	GRM188R61A225K	2.2µF	10		
Taiyo Yuden	LMK107BJ475KA	4.7µF	10	X5R	0603

Table 13: Surface Mount Capacitors.

ChargePump™ Backlight/Flash LED Driver and Multiple LDO Lighting Management Unit
Evaluation Board User Interface

The user interface for the AAT2861 evaluation board is provided by four buttons and a number of connection terminals. The board is operated by supplying external power and pressing individual buttons or button combinations. Table 14 indicates the function of each button or button combination.

To power-on the evaluation board, connect a power supply or battery to the DC- and DC+ terminals. A red LED indicates that power is applied.

The evaluation board is made flexible so that the user can disconnect the enable line from the microcontroller and apply external enable signal. External enable signal must be applied to the EN/SET pin.

When applying external enable signal, consideration must be given to the voltage levels. The externally applied voltage should not exceed the supply voltage that is applied to the IN pins of the device (DC+).

The LDO loads can be connected directly to the evaluation board. For adequate performance, be sure to connect the load between LDOA/LDOB/LDOC and DC- as opposed to some other GND in the system.

Button(s) Pushed	Description
SW1	[Push/Release once] LDOA, LDOB and LDOC outputs are programmed to 1.2V. With every subsequent push/release LDOA, LDOB and LDOC output voltages are incremented according to Table 8.
	[Push/hold more than 2 sec] LDOA, LDOB and LDOC outputs will start to cycle through all programmable voltage settings according to Table 8.
SW2	[Push/Release once] All channels are turned on as Main backlight with 31mA per channel. With every subsequent push/release the backlight current is decreased according to Table 4.
	[Push/hold more than 2 sec] All channels Main and Sub are turned on with 31mA per channel and fade out sequence is initiated. The cycle proceeds with fade in for Main channels only, followed by fade in sequence for Sub channels. When these sequences are finished the program will restart fade out sequence for all Main and Sub channels.
SW3	[Push/Release once] Flash channels are programmed with maximum current and timer. With every subsequent push/release the flash current is decreased according to Table 9. The FLASH button needs to be pressed down simultaneously.
FLASH	This button is connected directly to FL_EN pin. Press and hold for the flash to be enabled.

Table 14: AAT2861 Evaluation Board User Interface.

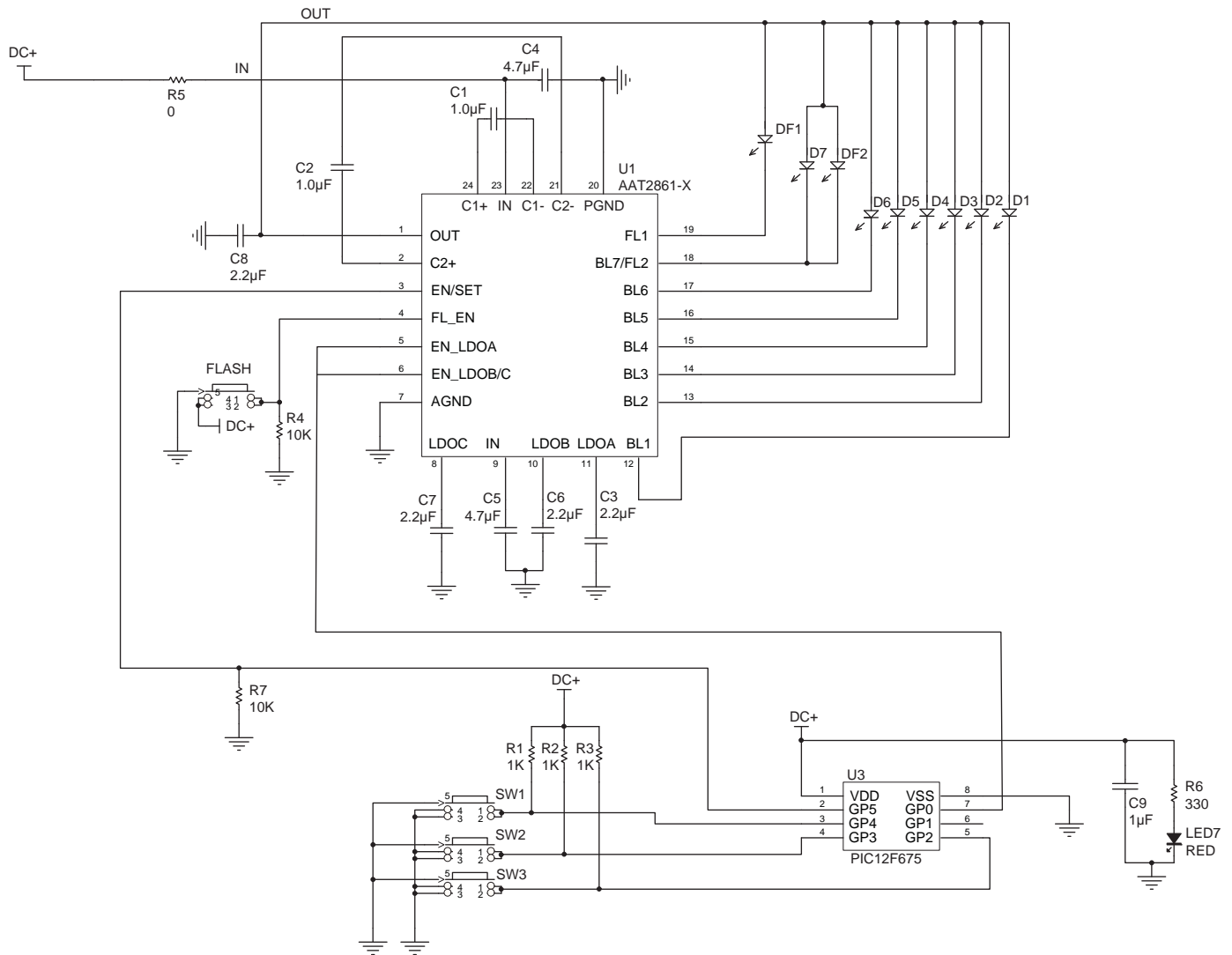

Figure 2: AAT2861 Evaluation Board Schematic.

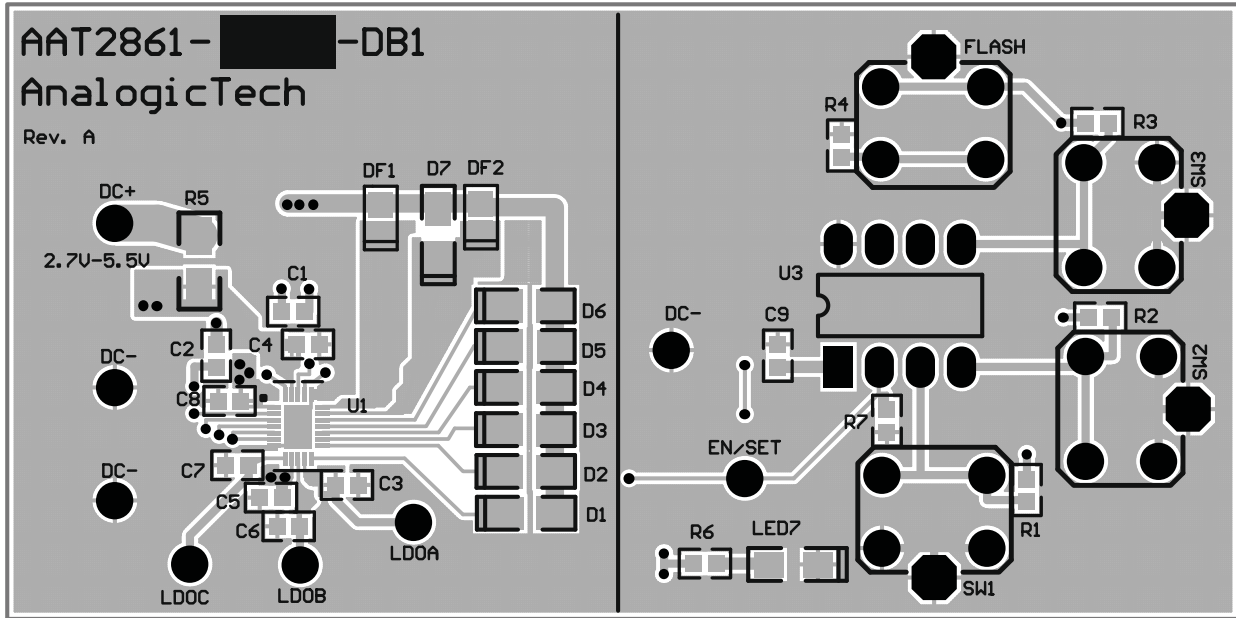

Figure 3: AAT2861 Evaluation Board Top Side Layout.

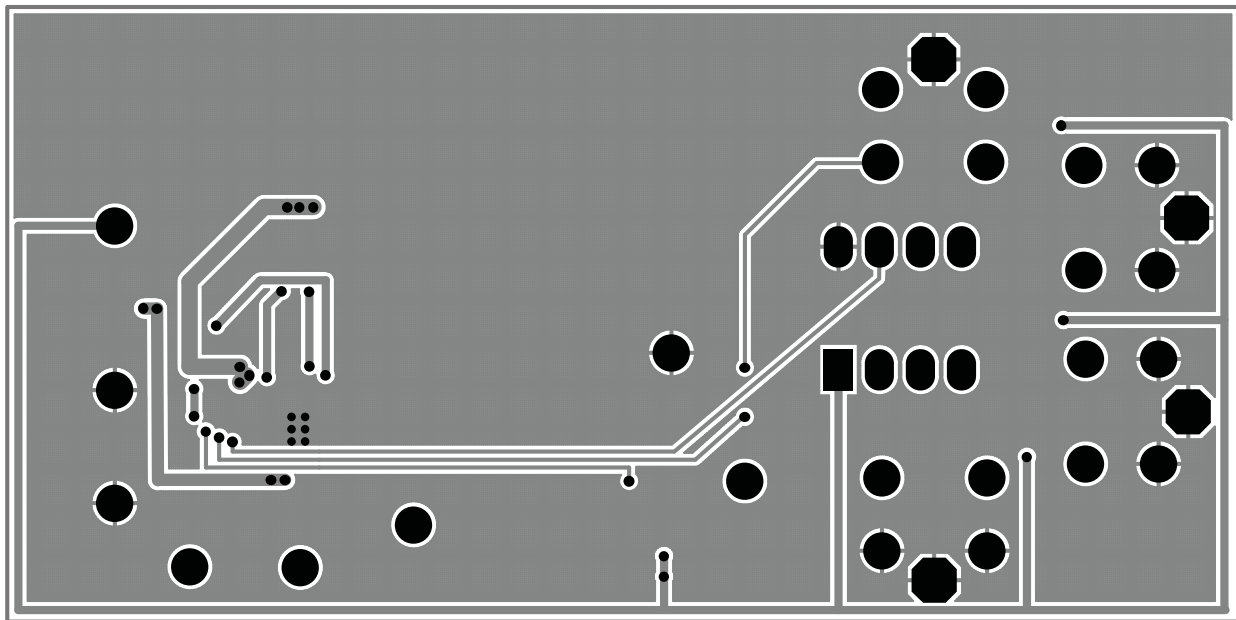

Figure 4: AAT2861 Evaluation Board Bottom Side Layout.

ChargePump™ Backlight/Flash LED Driver and Multiple LDO Lighting Management Unit

Component	Part#	Description	Manufacturer
U1	AAT2861IMK-x-T1	High Eff. 1X/1.5X/2X CP for White LED, Triple LDO	AnalogicTech
U2	PIC12F675	8-bit CMOS, FLASH MCU; 8-pin PDIP	Microchip
D1-D7	LW M673	Mini TOPLED White LED; SMT	OSRAM
DF1, DF2	LXCL PWF1	Mini TOPLED Flash LED; SMT	Lumileds, Philips
C1, C2	GRM18x	1.0 μ F, 10V, X5R, 0603, Ceramic	Murata
C3, C6, C7, C8	GRM18x	2.2 μ F, 10V, X5R, 0603, Ceramic	Murata
C4, C5	GRM18x	4.7 μ F, 10V, X5R, 0603, Ceramic	Murata
R1-R3	Chip Resistor	1K, 5%, 1/4W; 0603	Vishay
R4	Chip Resistor	10K, 5%, 1/4W; 0603	Vishay
R6	Chip Resistor	330, 5%, 1/4W; 1206	Vishay
R5	Chip Resistor	0, 5%, 1/4W; 1206	Rohm
LED7	CMD15-21SRC/TR8	Red LED; 1206	Chicago Miniature Lamp
SW1-SW3, FLASH	PTS645TL50	Switch Tact, SPST, 5mm	ITT Industries

Table 15: AAT2681 Evaluation Board Bill of Materials (BOM),

Ordering Information

Package	Marking ¹	Part Number (Tape and Reel) ²
TQFN34-24	4KXYY	AAT2861MK-1-T1
TQFN34-24	4LXYY	AAT2861MK-2-T1
TQFN34-24	4XXYY	AAT2861MK-3-T1



All AnalogicTech products are offered in Pb-free packaging. The term “Pb-free” means semiconductor products that are in compliance with current RoHS standards, including the requirement that lead not exceed 0.1% by weight in homogeneous materials. For more information, please visit our website at <http://www.analogictech.com/about/quality.aspx>.

Package Information

TQFN34-24³

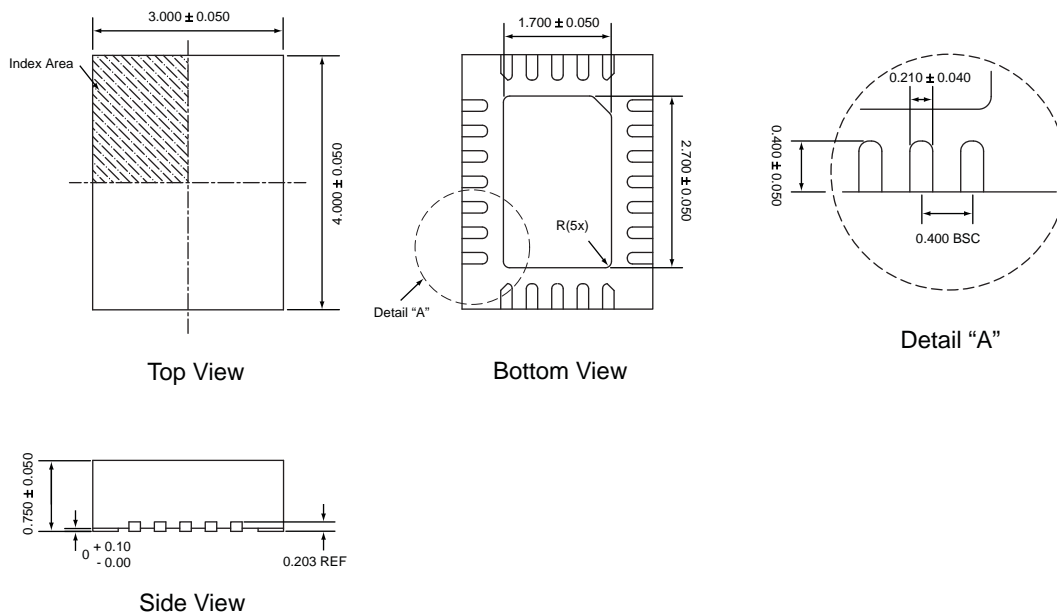

All dimensions in millimeters.

1. XYY = assembly and date code.
2. Sample stock is generally held on part numbers listed in **BOLD**.
3. The leadless package family, which includes QFN, TQFN, DFN, TDFN, and STDFN, has exposed copper (unplated) at the end of the lead terminals due to the manufacturing process. A solder fillet at the exposed copper edge cannot be guaranteed and is not required to ensure a proper bottom solder connection.

Advanced Analogic Technologies, Inc.
 3230 Scott Boulevard, Santa Clara, CA 95054
 Phone (408) 737-4600
 Fax (408) 737-4611



© Advanced Analogic Technologies, Inc. AnalogicTech cannot assume responsibility for use of any circuitry other than circuitry entirely embodied in an AnalogicTech product. No circuit patent licenses, copyrights, mask work rights, or other intellectual property rights are implied. AnalogicTech reserves the right to make changes to their products or specifications or to discontinue any product or service without notice. Except as provided in AnalogicTech's terms and conditions of sale, AnalogicTech assumes no liability whatsoever, and AnalogicTech disclaims any express or implied warranty relating to the sale and/or use of AnalogicTech products including liability or warranties relating to fitness for a particular purpose, merchantability, or infringement of any patent, copyright or other intellectual property right. In order to minimize risks associated with the customer's applications, adequate design and operating safeguards must be provided by the customer to minimize inherent or procedural hazards. Testing and other quality control techniques are utilized to the extent AnalogicTech deems necessary to support this warranty. Specific testing of all parameters of each device is not necessarily performed. AnalogicTech and the AnalogicTech logo are trademarks of Advanced Analogic Technologies Incorporated. All other brand and product names appearing in this document are registered trademarks or trademarks of their respective holders.