

Distance sensors

OADM 250U1101/S14C

dimension drawing

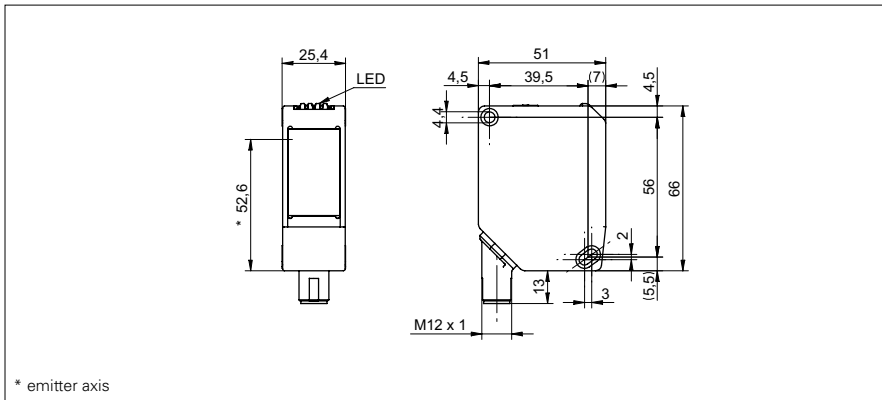

general data

measuring distance Sd	200 ... 4000 mm
measuring distance Sd (white 90%)	200 ... 4000 mm
measuring distance Sd (grey 18%)	200 ... 4000 mm
measuring distance Sd (black 6%)	200 ... 4000 mm
adjustment	Teach-in: button / external
Teach-in range min.	> 100 mm
power on indication	LED green
soiled lens indicator	LED red
resolution	1,3 mm
linearity	± 15 mm
repeatability	± 5 mm (with 40 kLux ambient light)
light source	pulsed red laser diode
wave length	660 nm
laser class	2
beam type	point
beam diameter	5 ... 20 mm

electrical data

measuring rate	10 ms
voltage supply range +Vs	15 ... 28 VDC
current consumption max. (no load)	250 mA (typ. 110 mA @ 24V)
output circuit	analog
output signal	0 ... 10 VDC
load resistance (analog U)	> 10 kOhm
output current	< 100 mA
alarm output	push-pull
short circuit protection	yes
reverse polarity protection	yes, Vs to GND

mechanical data

width / diameter	25,4 mm
height / length	66 mm
depth	51 mm
type	rectangular
housing material	aluminum
front (optics)	glass
connection types	connector M12 5 pin, rotatable

photo



connection diagram

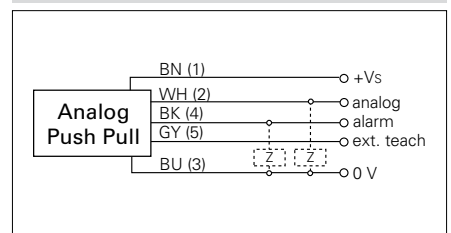

laser warning

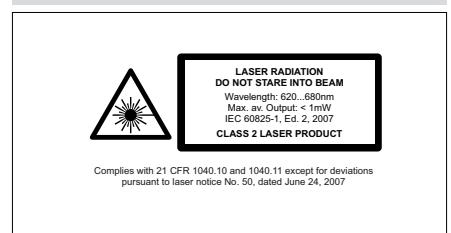

Distance sensors**OADM 250U1101/S14C****ambient conditions**

ambient light immunity	< 40 kLux
operating temperature	-25 ... +50 °C
protection class	IP 67
typ. temp. coefficient	0,2 mm /°C