

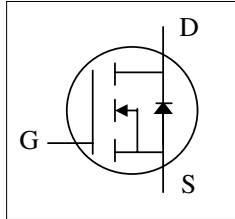

- ▼ Lower On- resistance
- ▼ Simple Drive Requirement
- ▼ Fast Switching Characteristic



BV_{DSS}	30V
$R_{DS(ON)}$	4m Ω
I_D	75A

Description

Advanced Power MOSFETs from APEC provide these signer with the best combination of fast-switching, ruggedized device design, low on-resistance and cost-effectiveness.

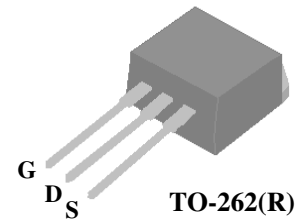

Absolute Maximum Ratings

Symbol	Parameter	Rating	Units
V_{DS}	Drain-Source Voltage	30	V
V_{GS}	Gate-Source Voltage	± 20	V
$I_D@T_c=25^\circ\text{C}$	Continuous Drain Current, $V_{GS}@10\text{V}^3$	75	A
$I_D@T_c=100^\circ\text{C}$	Continuous Drain Current, $V_{GS}@10\text{V}$	63	A
I_{DM}	Pulsed Drain Current ¹	350	A
$P_D@T_c=25^\circ\text{C}$	Total Power Dissipation	96	W
	Linear Derating Factor	0.7	W/ $^\circ\text{C}$
T_{STG}	Storage Temperature Range	-55 to 150	$^\circ\text{C}$
T_J	Operating Junction Temperature Range	-55 to 150	$^\circ\text{C}$

Thermal Data

Symbol	Parameter	Value	Units
Rthj-c	Maximum Thermal Resistance, Junction-case	1.3	$^\circ\text{C}/\text{W}$
Rthj-a	Maximum Thermal Resistance, Junction-ambient	62	$^\circ\text{C}/\text{W}$



Electrical Characteristics@T_j=25°C(unless otherwise specified)

Symbol	Parameter	Test Conditions	Min.	Typ.	Max.	Units
BV _{DSS}	Drain-Source Breakdown Voltage	V _{GS} =0V, I _D =1mA	30	-	-	V
R _{DS(ON)}	Static Drain-Source On-Resistance ²	V _{GS} =10V, I _D =45A	-	-	4	mΩ
		V _{GS} =4.5V, I _D =30A	-	-	6	mΩ
V _{GS(th)}	Gate Threshold Voltage	V _{DS} =V _{GS} , I _D =250uA	0.8	-	3	V
g _{fs}	Forward Transconductance	V _{DS} =10V, I _D =30A	-	55	-	S
I _{DSS}	Drain-Source Leakage Current	V _{DS} =30V, V _{GS} =0V	-	-	1	uA
	Drain-Source Leakage Current (T _j =150°C)	V _{DS} =24V, V _{GS} =0V	-	-	25	uA
I _{GSS}	Gate-Source Leakage	V _{GS} = ±20V	-	-	±100	nA
Q _g	Total Gate Charge ²	I _D =40A	-	60	96	nC
Q _{gs}	Gate-Source Charge	V _{DS} =24V	-	8.5	-	nC
Q _{gd}	Gate-Drain ("Miller") Charge	V _{GS} =4.5V	-	38	-	nC
t _{d(on)}	Turn-on Delay Time ²	V _{DS} =15V	-	14	-	ns
t _r	Rise Time	I _D =30A	-	83	-	ns
t _{d(off)}	Turn-off Delay Time	R _G =3.3Ω, V _{GS} =10V	-	66	-	ns
t _f	Fall Time	R _D =0.5Ω	-	120	-	ns
C _{iss}	Input Capacitance	V _{GS} =0V	-	4090	6540	pF
C _{oss}	Output Capacitance	V _{DS} =25V	-	1010	-	pF
C _{rss}	Reverse Transfer Capacitance	f=1.0MHz	-	890	-	pF

Source-Drain Diode

Symbol	Parameter	Test Conditions	Min.	Typ.	Max.	Units
V _{SD}	Forward On Voltage ²	I _S =45A, V _{GS} =0V	-	-	1.3	V
t _{rr}	Reverse Recovery Time ²	I _S =30A, V _{GS} =0V,	-	51	-	ns
Q _{rr}	Reverse Recovery Charge	di/dt=100A/μs	-	63	-	nC

Notes:

- 1.Pulse width limited by Max. junction temperature.
- 2.Pulse test
- 3.Package limitation current is 75A, calculated continuous current based on maximum allowable junction temperature is 125A.

THIS PRODUCT IS AN ELECTROSTATIC SENSITIVE, PLEASE HANDLE WITH CAUTION.

THIS PRODUCT HAS BEEN QUALIFIED FOR CONSUMER MARKET. APPLICATIONS OR USES AS CRITERIAL COMPONENT IN LIFE SUPPORT DEVICE OR SYSTEM ARE NOT AUTHORIZED.

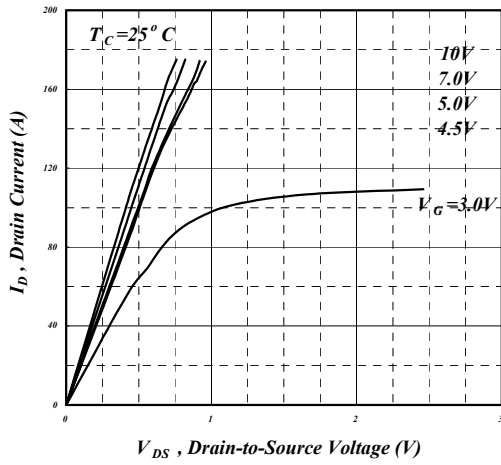

Fig 1. Typical Output Characteristics

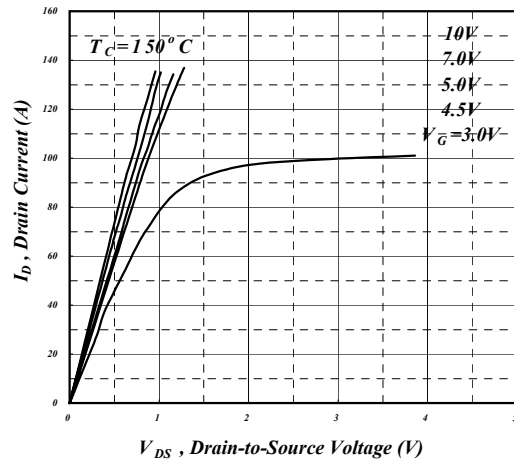

Fig 2. Typical Output Characteristics

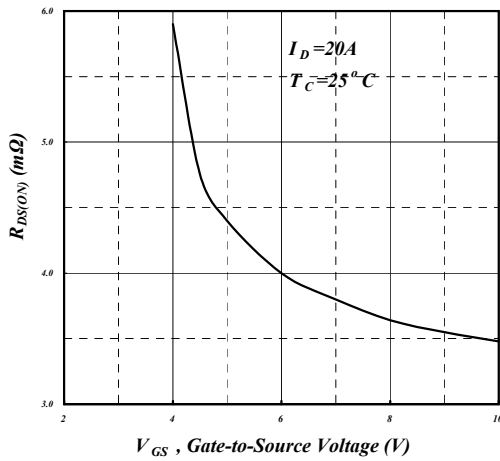

Fig 3. On-Resistance v.s. Gate Voltage

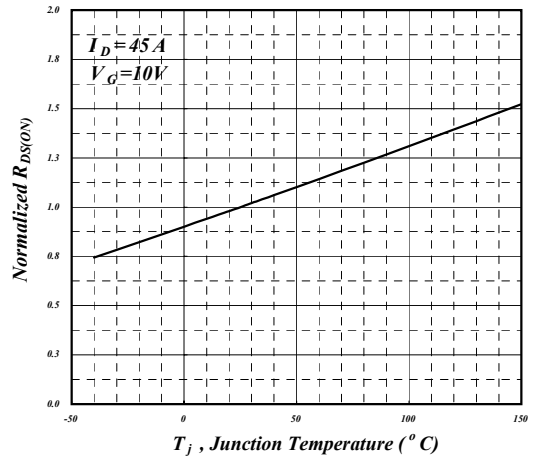

Fig 4. Normalized On-Resistance v.s. Junction Temperature

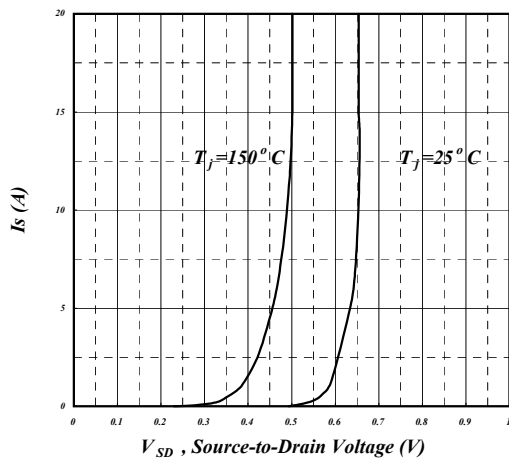

Fig 5. Forward Characteristic of Reverse Diode

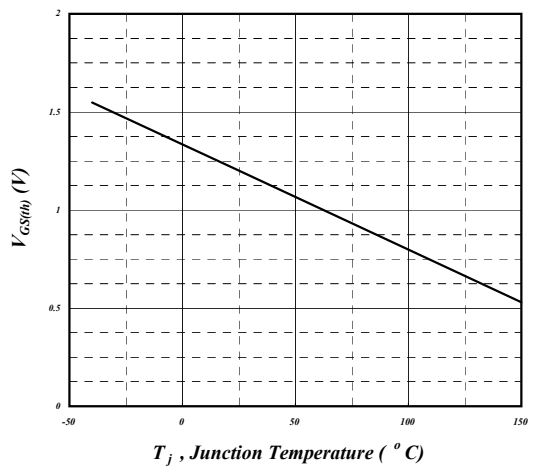

Fig 6. Gate Threshold Voltage v.s. Junction Temperature

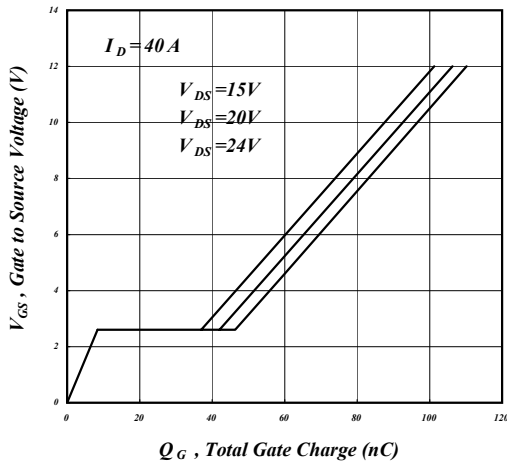

Fig 7. Gate Charge Characteristics

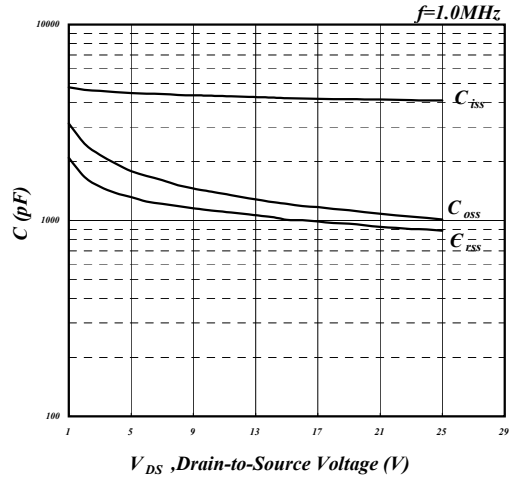

Fig 8. Typical Capacitance Characteristics

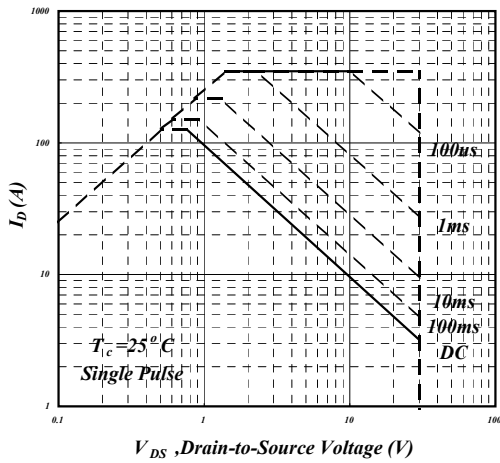

Fig 9. Maximum Safe Operating Area

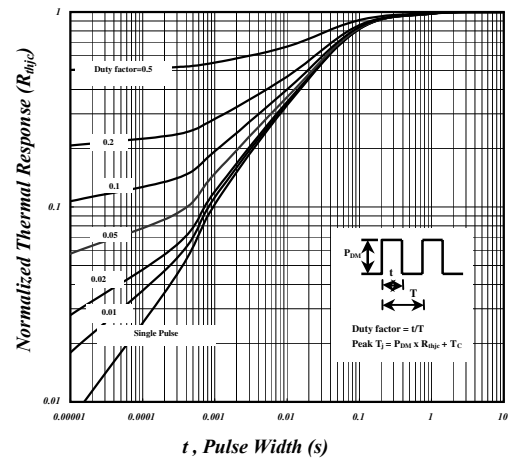

Fig 10. Effective Transient Thermal Impedance

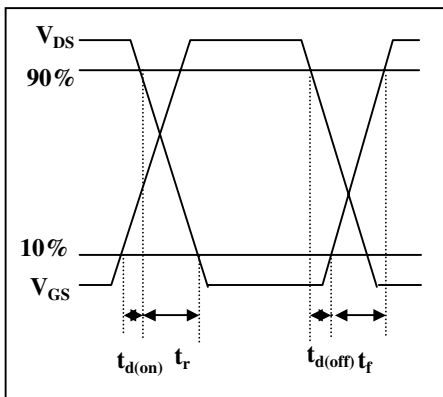

Fig 11. Switching Time Waveform

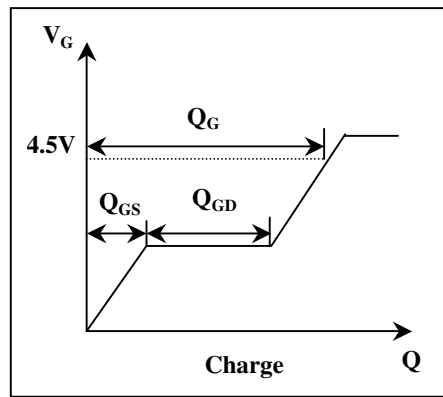
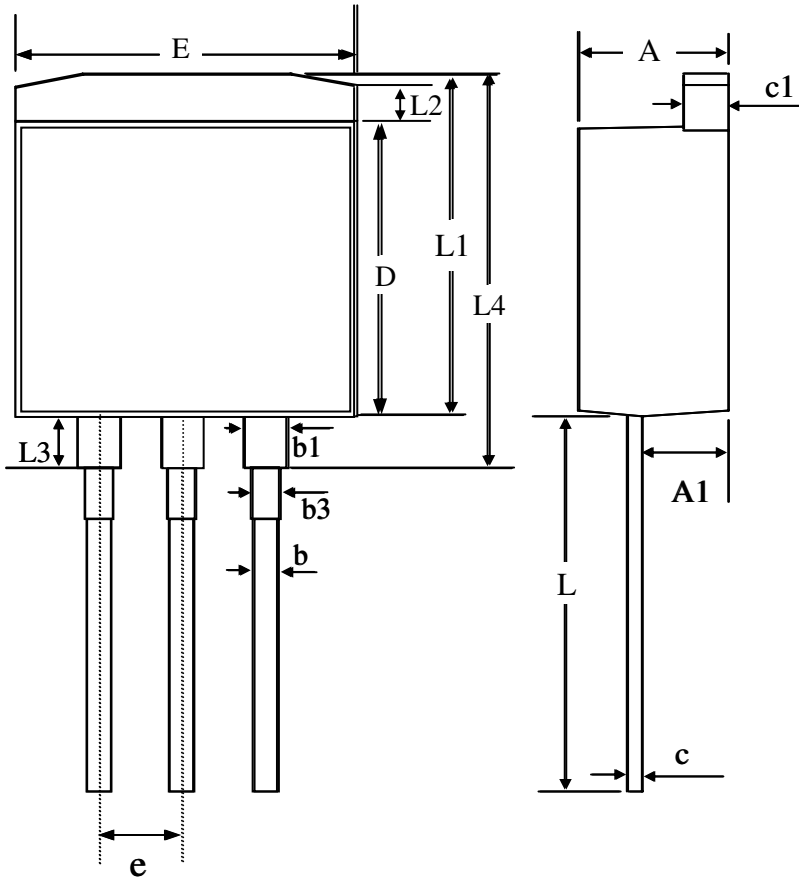

Fig 12. Gate Charge Waveform



Package Outline : TO-262



SYMBOLS	Millimeters		
	MIN	NOM	MAX
A	4.24	4.44	4.64
A1	-----	-----	2.70
b	0.66	0.76	0.86
b1	1.07	1.27	1.47
b3	0.76	0.86	1.06
c	0.30	0.40	0.50
c1	1.15	1.30	1.45
D	8.30	8.60	8.90
E	9.90	10.20	10.50
e	2.04	2.54	3.04
L	10.50	11.00	11.50
L1	9.50	10.00	10.30
L3	----	1.30	----
L4	10.80	11.30	11.35

- 1.All Dimensions Are in Millimeters.
- 2.Dimension Does Not Include Mold Protrusions.

Part Marking Information & Packing : TO-262

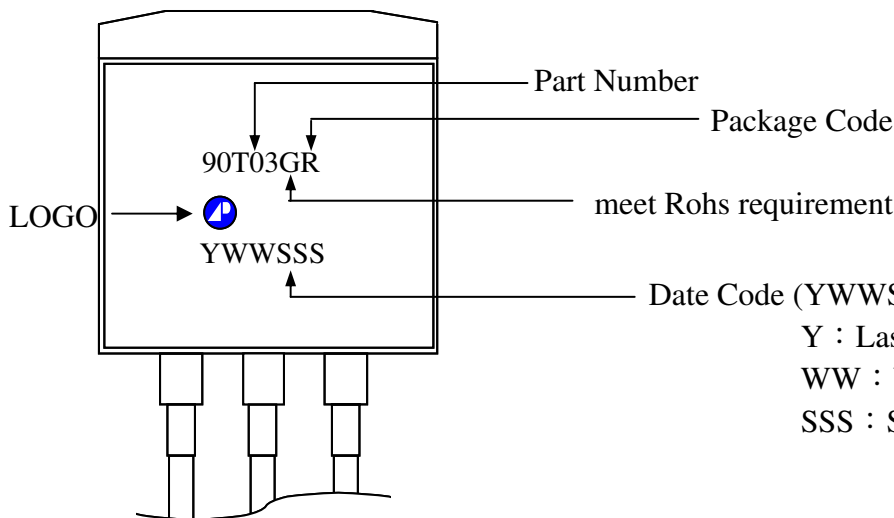

Y : Last Digit Of The Year
 WW : Week
 SSS : Sequence