



1A LOW DROPOUT LINEAR REGULATOR

FEATURES

- 1.5V Maximum Dropout at Full Load Current
- Fast Transient Response
- Output Current Limiting
- Built-in Thermal Shutdown
- Good Noise Rejection
- Need only 1uF Capacitor for Stability
- Low-ESR Ceramic Capacitor Required for Output Stability.
- 3-Terminal Adjustable or Fixed 1.5V, 1.8V, 2.5V, 3.3V, 5.0V
- Packages : SOT-223, TO-252, SOT-89.

DESCRIPTION

APE1117A is a low dropout positive adjustable or fixed-mode regulator with minimum of 1A output current capability. The product is specifically designed to provide well-regulated supply for low voltage IC applications such as high-speed bus termination and low current 3.3V logic supply. APE1117A is also well suited for other applications such as VGA cards. APE1117A is guaranteed to have lower than 1.4V dropout at full load current making it ideal to provide well-regulated outputs of 1.25 to 5.0 with 6.4V to 12V input supply.

TYPICAL APPLICATION

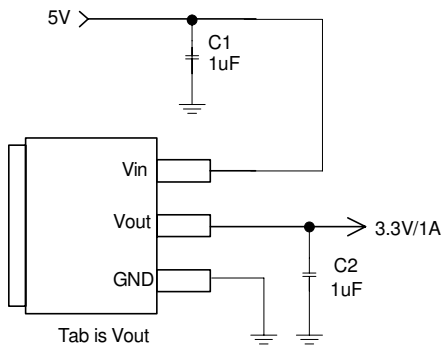

(5V/3.3V fixed output)

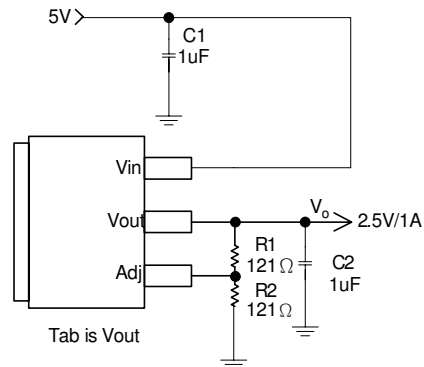

(5V/2.5V ADJ output)

$$\text{Note : } V_o = V_{REF} \times \left(1 + \frac{R_2}{R_1}\right)$$



ABSOLUTE MAXIMUM RATINGS (at $T_A=25^\circ\text{C}$)

DC Supply Voltage(V_{IN})	-----	-0.3V to 15V
Power Dissipation(P_D) ^{Note}	@ $T_A=25^\circ\text{C}$, $T_J=125^\circ\text{C}$	
	SOT-223 -----	850mW
	SOT-89 -----	330mW
	TO-252 -----	1050mW
Storage Temperature Range(T_{ST})	-----	-65°C To 150°C
Operating Junction Temperature Range(T_J)	-----	-40°C To 125°C
Maximum Junction Temperature(T_{MJ})	-----	150°C
Thermal Resistance from Junction to Case(R_{thjc})		
	SOT-223 -----	15°C/W
	SOT-89 -----	100°C/W
	TO-252 -----	10°C/W
Thermal Resistance from Junction to Ambient(R_{thja}) ^{Note}		
	SOT-223 -----	117°C/W
	SOT-89 -----	300°C/W
	TO-252 -----	92°C/W

Note. No heat sink; No air flow)

ORDERING/PACKAGE INFORMATION

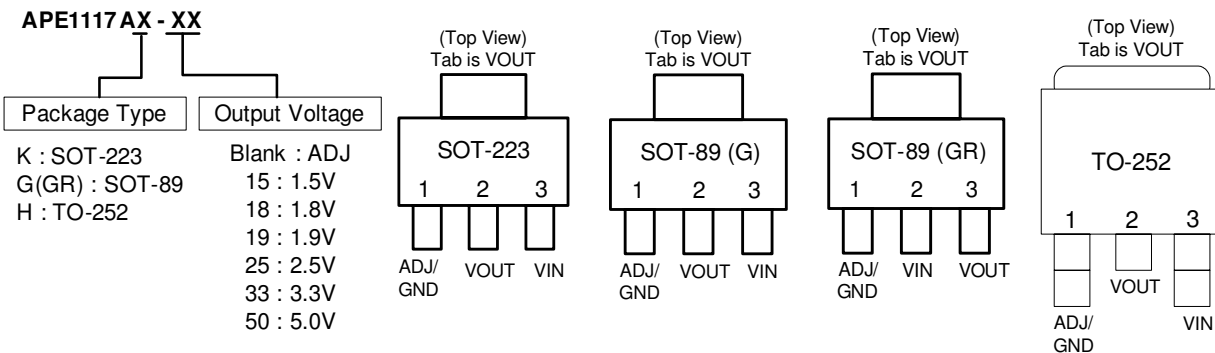

ELECTRICAL SPECIFICATIONS

($T_A=25^\circ\text{C}$, unless otherwise specified)

Parameter	TEST CONDITION	MIN	TYP	MAX	UNITS
Operation Input Voltage		2.75	-	12	V
Dropout Voltage($V_{IN}-V_{OUT}$)	APE1117AX-ADJ/15/18/25 /33/50 $I_{OUT} = 1A$, $\delta V_{OUT}=1\%V_{OUT}$	-	1.3	1.5	V
Current Limit	APE1117AX-ADJ/15/18/25 /33/50 $(V_{IN}-V_{OUT}) = 3V$	1.1	-	-	A
Minimum Load Current	APE1117AX-XX $0^\circ\text{C} \leq T_J \leq 125^\circ\text{C}$	-	5	10	mA
Line Regulation	APE1117AX-XX $I_{OUT}=10\text{mA}$, $V_{OUT}+1.5\text{V}<V_{IN}<V_{OUT}+12\text{V}$, $T_J=25^\circ\text{C}$ (Note 1,2)	-	0.2	0.5	%



ELECTRICAL SPECIFICATIONS(Cont.)

Parameter	TEST CONDITION	MIN	TYP	MAX	UNITS
Load Regulation	APE1117AX-ADJ $V_{IN}=3.3V, 10mA \leq I_{OUT} \leq 1A, T_J=25^\circ C$	-	0.4	1	%
	APE1117AX-15 $V_{IN}=3V, 10mA \leq I_{OUT} \leq 1A, T_J=25^\circ C$ (Note 1,2)	-	12	15	mV
	APE1117AX-18 $V_{IN}=3.3V, 0mA \leq I_{OUT} \leq 1A, T_J=25^\circ C$ (Note 1,2)	-	15	18	mV
	APE1117AX-25 $V_{IN}=4V, 10mA \leq I_{OUT} \leq 1A, T_J=25^\circ C$ (Note 1,2)	-	20	25	mV
	APE1117AX-33 $V_{IN}=5V, 10mA \leq I_{OUT} \leq 1A, T_J=25^\circ C$ (Note 1,2)	-	26	33	mV
	APE1117AX-50 $V_{IN}=6.5V, 10mA \leq I_{OUT} \leq 1A, T_J=25^\circ C$ (Note 1,2)	-	40	50	mV
Reference Voltage	APE1117AX-ADJ $I_{OUT} = 10mA, T_J=25^\circ C, (V_{IN}-V_{OUT})=1.5V$	1.225	1.25	1.275	V
Output Voltage	APE1117AX-15 $I_{OUT} = 10mA, T_J = 25^\circ C, 3V \leq V_{IN} \leq 12V$	1.47	1.5	1.53	V
	APE1117AX-18 $I_{OUT} = 10mA, T_J = 25^\circ C, 3.3V \leq V_{IN} \leq 12V$	1.764	1.8	1.836	V
	APE1117AX-25 $I_{OUT} = 10mA, T_J = 25^\circ C, 4V \leq V_{IN} \leq 12V$	2.45	2.5	2.55	V
	APE1117AX-33 $I_{OUT} = 10mA, T_J = 25^\circ C, 4.8V \leq V_{IN} \leq 12V$	3.235	3.3	3.365	V
	APE1117AX-50 $I_{OUT} = 10mA, T_J = 25^\circ C, 6.5V \leq V_{IN} \leq 12V$	4.9	5	5.1	V
Ripple Rejection	$F=120Hz, C_{OUT}=10\mu F, APE1117AX-XX, (V_{IN}-V_{OUT}) = 3V, I_{OUT} = 1A$	-	60	70	dB
Temperature Stability	$I_{OUT}=10mA$	-	0.5	-	%

Note1: See thermal regulation specifications for changes in output voltage due to heating effects. Line and load regulation are measured at a constant junction temperature by low duty cycle pulse testing. Load regulation is measured at the output lead = 1/18" from the package.

Note2: Line and load regulation are guaranteed up to the maximum power dissipation of 15W. Power dissipation is determined by the difference between input and output differential and the output current. Guaranteed maximum power dissipation will not be available over the full input/output range.

Note3: Quiescent current is defined as the minimum output current required in maintaining regulation. At 12V input/output differential the device is guaranteed to regulate if the output current is greater than 10mA.



PIN DESCRIPTIONS

PIN SYMBOL	PIN DESCRIPTION
ADJ/GND	A resistor divider from this pin to the V _{OUT} pin and ground sets the output voltage. (Ground only for Fixed-Mode)
VOUT	The output of the regulator. A minimum of 1 μ F capacitor (10m Ω < ESR < 1 Ω) must be connected from this pin to ground to insure stability.
VIN	The input pin of regulator. A minimum of 1 μ F capacitor is connected from this pin to ground to insure that the input voltage does not sag below the minimum dropout voltage during the load transient response. This pin must always be 1.5V higher than V _{OUT} in order for the device to regulate properly.

BLOCK DIAGRAM

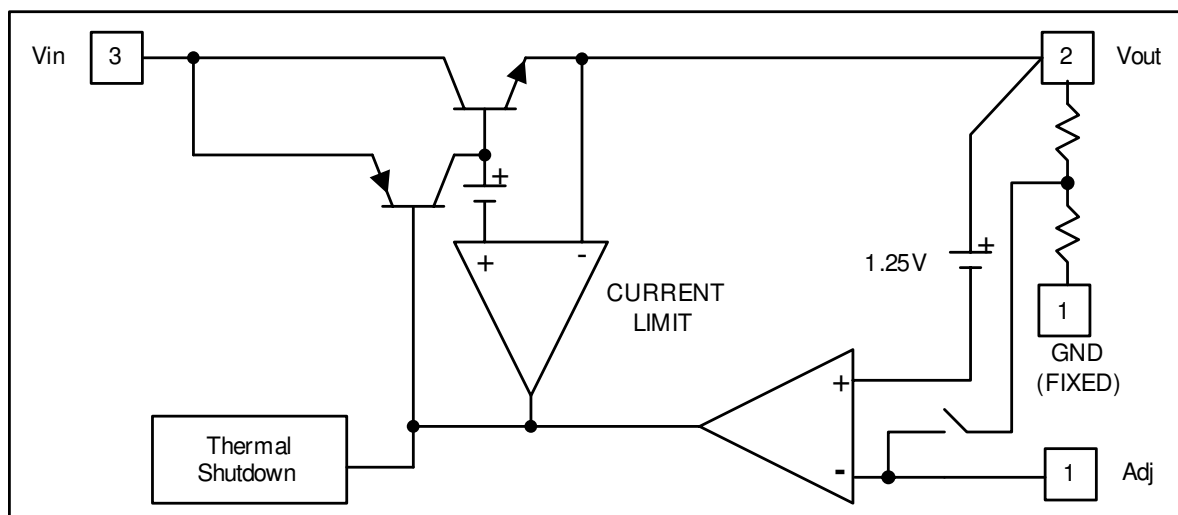



TYPICAL PERFORMANCE CHARACTERISTICS

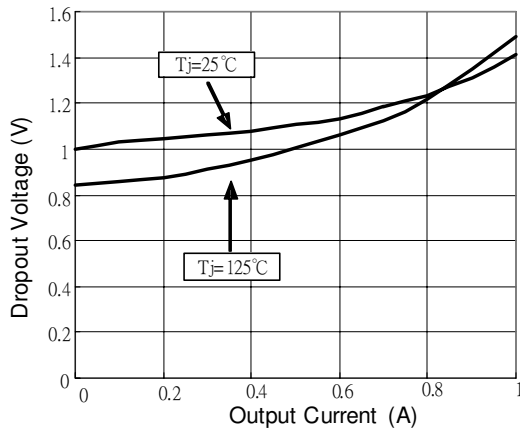

Dropout Voltage vs Output Current

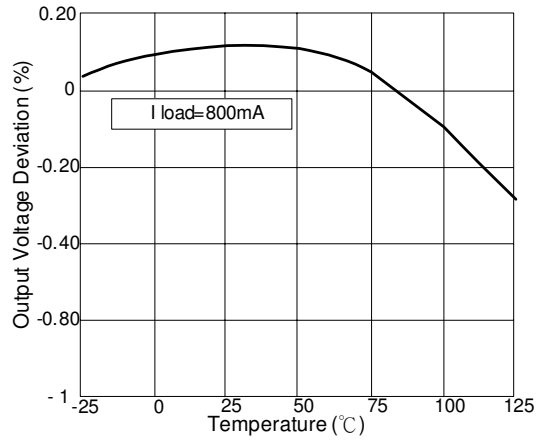

Load Regulation vs Temperature

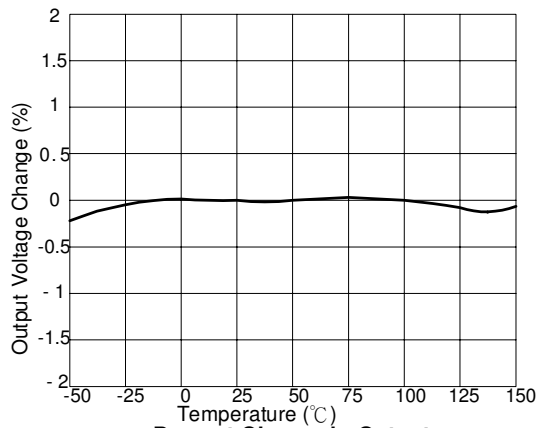

Percent Change in Output Voltage vs Temperature

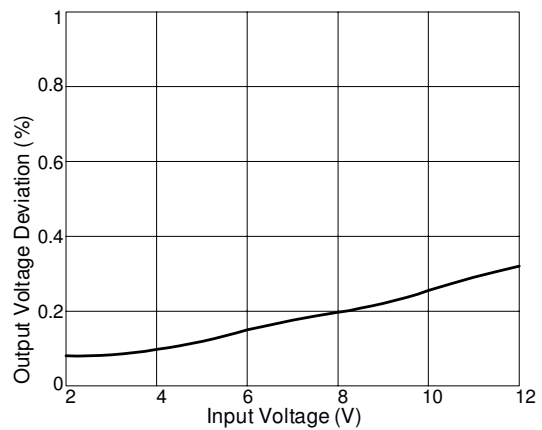

Line Regulation

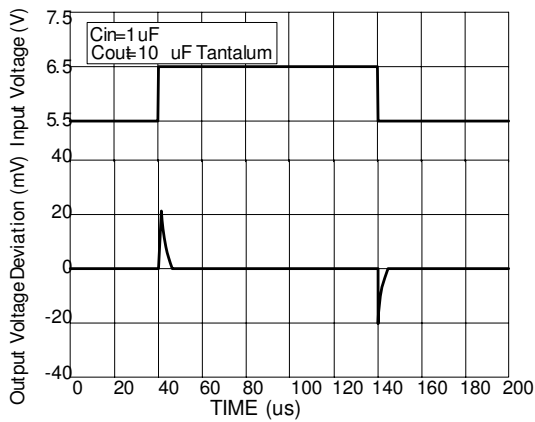

Line Transient Response

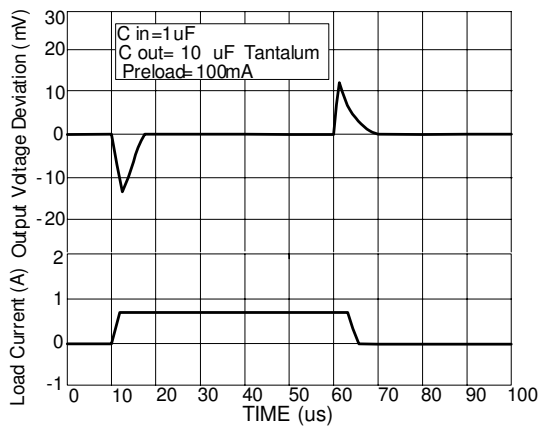

Load Transient Response



MARKING INFORMATION

SOT-223

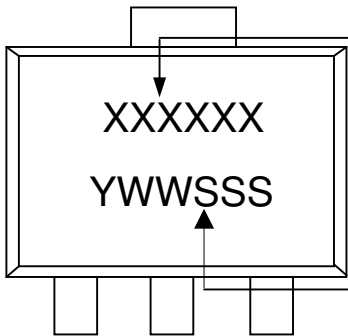

Part Number :

Part Number	Marking
APE1117AK	1117A
APE1117AK-15	117A-15
APE1117AK-18	117A-18
APE1117AK-19	117A-19
APE1117AK-25	117A-25
APE1117AK-33	117A-33
APE1117AK-50	117A-50

Date Code (YWWSSS)

Y:Year
WW : Week
SSS : Sequence

SOT-89

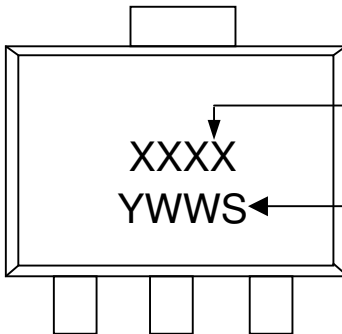

Identification code :

Part Number	Identification code
APE1117AG(GR)	17AA(R)
APE1117AG(GR)-15	17AB(R)
APE1117AG(GR)-18	17AC(R)
APE1117AG(GR)-19	17AG(R)
APE1117AG(GR)-25	17AD(R)
APE1117AG(GR)-33	17AE(R)
APE1117AG(GR)-50	17AF(R)

Date Code (YWWS)

Y:Year
WW : Week
S : Sequence

TO-252

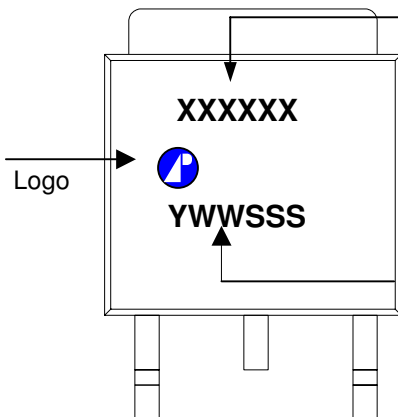

Part Number :

Part Number	Marking
APE1117AH	1117A
APE1117AH-15	117A-15
APE1117AH-18	117A-18
APE1117AH-19	117A-19
APE1117AH-25	117A-25
APE1117AH-33	117A-33
APE1117AH-50	117A-50

Date Code (YWWSSS)

Y : Last Digit Of The Year
WW : Week
SSS : Sequence