



1.5A Low Dropout Positive Adjustable or Fixed-Mode Regulator

■ **Features**

- 3-Terminal Adjustable or Fixed 1.5V, 1.8V, 2.5V, 3.3V, 5.0V
- 1.4V Maximum Dropout at Full Load Current
- Fast Transient Response
- Built-in Thermal Shutdown
- Output Current Limiting
- RoHS Compliant

■ **General Description**

APE1086 is a low dropout positive adjustable or fixed-mode regulator with minimum of 1.5A output current capability. The product is specifically designed to provide well-regulated supply for low voltage IC applications such as high-speed bus termination and low current 3.3V logic supply. APE1086 is also well suited for other applications such as VGA cards. APE1086 is guaranteed to have <1.4V dropout at full load current making it ideal to provide well-regulated outputs of 1.25V to 5.0V with 4.7 to 12V input supply by different output voltage.

■ **Ordering Information**

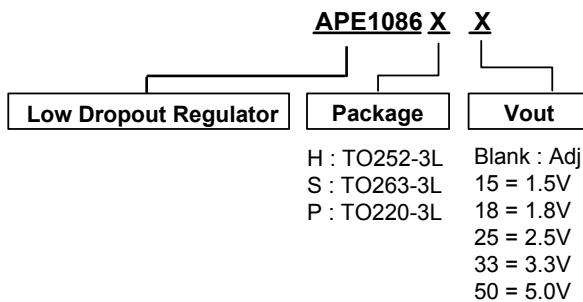

■ **Typical Application**

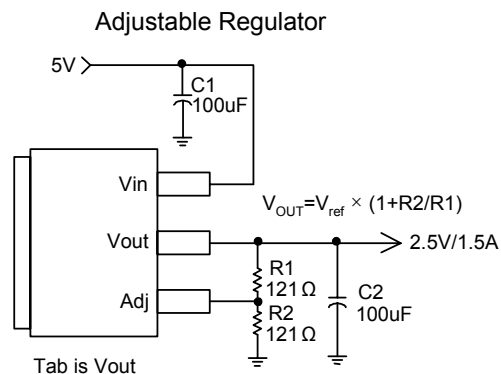
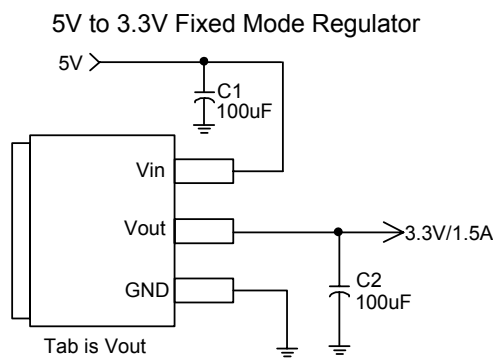

Note: $V_o = V_{REF} * (1 + \frac{R_2}{R_1})$



1.5A Low Dropout Positive Adjustable or Fixed-Mode Regulator

Block Diagram

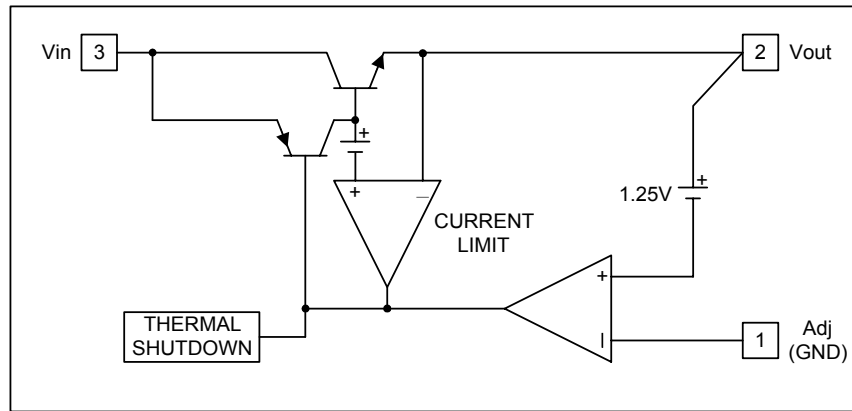

Connection Diagram

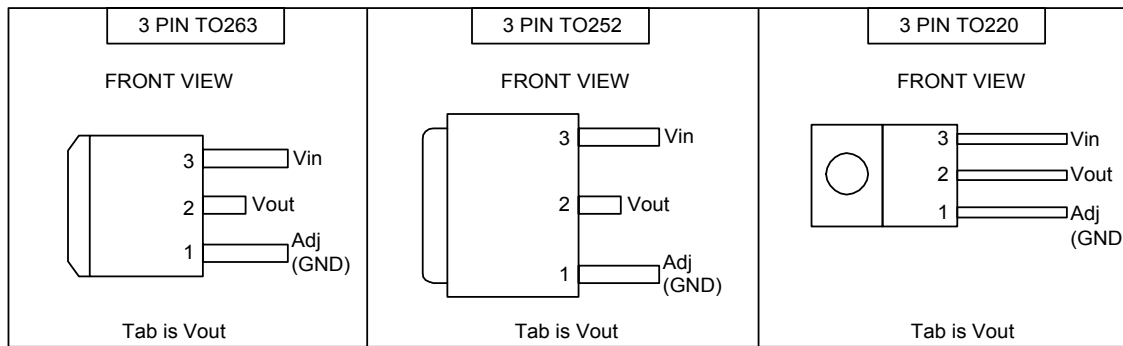

Pin Descriptions

Table with 4 columns: NAME, I/O, PIN #, and FUNCTION. It describes the Adj (GND), Vout, and Vin pins.



1.5A Low Dropout Positive Adjustable or Fixed-Mode Regulator

■ Absolute Maximum Ratings

Symbol	Parameter	Rating	Unit
V _{IN}	DC Supply Voltage	-0.3 to 12	V
P _D	Power Dissipation	Internally Limited	
T _{ST}	Storage Temperature	-65 to +150	°C
T _{OP}	Operating Junction Temperature Range	0 to +150	°C

■ Electrical Characteristics (Under Operating Conditions)

PARAMETER	CONDITIONS		MIN	TYP	MAX	UNIT
Reference Voltage	APE1086-Adj	T _J =25°C, (V _{IN} -V _{OUT})=1.5V, I _O =10mA	1.225	1.250	1.275	V
Output Voltage	APE1086-1.5	I _{OUT} = 10mA, T _J = 25°C, 3V ≤ V _{IN} ≤ 12V	1.470	1.500	1.530	V
	APE1086-1.8	I _{OUT} = 10mA, T _J = 25°C, 3.3V ≤ V _{IN} ≤ 12V	1.764	1.800	1.836	V
	APE1086-2.5	I _{OUT} = 10mA, T _J = 25°C, 4V ≤ V _{IN} ≤ 12V	2.450	2.500	2.550	V
	APE1086-3.3	I _{OUT} = 10mA, T _J = 25°C, 4.8V ≤ V _{IN} ≤ 12V	3.235	3.300	3.365	V
	APE1086-5.0	I _{OUT} = 10mA, T _J = 25°C, 6.5V ≤ V _{IN} ≤ 12V	4.900	5.000	5.100	V
Line Regulation	APE1086-XX	I _O =10mA, V _{OUT} +1.5V<V _{IN} <12V	-	0.2	0.5	%
Load Regulation	APE1086-Adj	V _{IN} =3.3V, 0mA<I _O <1.5A, T _J =25°C (Note 1, 2)	-	-	1	%
	APE1086-1.5	V _{IN} =3V, 0mA<I _O <1.5A, T _J =25°C (Note 1, 2)	-	12	15	mV
	APE1086-1.8	V _{IN} =3.3V, 0mA<I _O <1.5A, T _J =25°C (Note 1, 2)	-	15	18	mV
	APE1086-2.5	V _{IN} =4V, 0mA<I _O <1.5A, T _J =25°C (Note 1, 2)	-	20	25	mV
	APE1086-3.3	V _{IN} = 5V, 0 ≤ I _{OUT} ≤ 1.5A, T _J =25°C , T _J =25°C (Note 1.2)	-	26	33	mV
	APE1086-5.0	V _{IN} = 8V, 0 ≤ I _{OUT} ≤ 1.5A, T _J =25°C , T _J =25°C (Note 1.2)	-	40	50	mV
Dropout Voltage (V _{IN} -V _{OUT})	APE1086-Adj/-2.5/-3.3/-3.6/-5.0	I _{OUT} = 1.5A, ΔV _{OUT} =1%V _{OUT}	-	1.3	1.4	V
Current Limit	APE1086-Adj/-2.5/-3.3/-3.6/-5.0	(V _{IN} -V _{OUT}) = 5V	1.6	-	-	A
Minimum Load Current	APE1086-XX	0°C ≤ T _J ≤ 125°C	-	5	10	mA
Thermal Regulation	T _A =25°C, 30ms pulse		-	0.008	0.04	%/W
Ripple Rejection	F=120Hz, C _{OUT} =25uF Tantalum, I _{OUT} =1.5A		-	-	-	-
	APE1086-XX	V _{IN} =V _{OUT} +3V	-	60	70	dB
RMS Noise (% of V _{OUT})	10Hz ≤ f ≤ 10KHz		-	0.003	-	%
Temperature Stability	I _O =10mA		-	0.5	-	%
Thermal Resistance Junction-to-Ambient (No heat sink ;No air flow)	TO-252		-	101	-	°C/W
	TO-263		-	83	-	°C/W
	TO-220		-	86	-	°C/W
Thermal Resistance Junction-to-Case	TO-252: Control Circuitry/Power Transistor		-	15	-	°C/W
	TO-263: Control Circuitry/Power Transistor		-	0.65/2.7	-	°C/W
	TO-220: Control Circuitry/Power Transistor		-	0.65/2.7	-	°C/W

Note 1: See thermal regulation specifications for changes in output voltage due to heating effects. Line and load regulation are measured at a constant junction temperature by low duty cycle pulse testing. Load regulation is measured at the output lead = 1/18" from the package.

Note 2: Line and load regulation are guaranteed up to the maximum power dissipation of 15W. Power dissipation is determined by the difference in input and output and the output current. Guaranteed maximum power dissipation will not be available over the full input/output range.

Note 3: Quiescent current is defined as the minimum output current required in maintaining regulation. At 12V input/output differential the device is guaranteed to regulate if the output current is greater than 10mA.



1.5A Low Dropout Positive Adjustable or Fixed-Mode Regulator

■ **Functional Description**

Introduction

The APE1086 adjustable or fixed-mode Low Dropout (LDO) regulator is a 3 terminal device which can easily be programmed by internal mask change to any voltages within the range of 1.25V to $V_{in}-1.4V$. The APE1086 only needs 1.4V differential between V_{in} and V_{out} to maintain output regulation. In addition, the output voltage tolerances are also extremely tight and they include the transient response as part of the specification. For example, Intel VRE specification calls for a total of $\pm 100mV$ including initial tolerance, load regulation and 0 to 1.5A load step.

The APE1086 is specifically designed to meet the fast current transient needs as well as providing an accurate initial voltage, reducing the overall system cost with the need for fewer output capacitors.

Load Regulation

Since the APE1086 is only a 3 terminal device, it is not possible to provide true remote sensing of the output voltage at the load. But it can supply good load regulation by internal feedback bypass the external loss such as adjustable mode.

Stability

The APE1086 requires the use of an output capacitor as part of the frequency compensation in order to

make the regulator stable. For most applications a minimum of 10uF aluminum electrolytic capacitor insures both stability and good transient response.

Thermal Design

The APE1086 incorporates an internal thermal shutdown that protects the device when the junction temperature exceeds the maximum allowable junction temperature. Although this device can operate with junction temperatures in the range of 150°C, it is recommended that the selected heat sink be chosen such that during maximum continuous load operation the junction temperature is kept below the temperature.

Layout Consideration

The output capacitors must be located as close to the V_{out} terminal of the device as possible. It is recommended to use a section of a layer of the PC board as a plane to connect the V_{out} pin to the output capacitors to prevent any high frequency oscillation that may result due to excessive trace inductance.



1.5A Low Dropout Positive Adjustable or Fixed-Mode Regulator

■ Typical Performance Characteristics

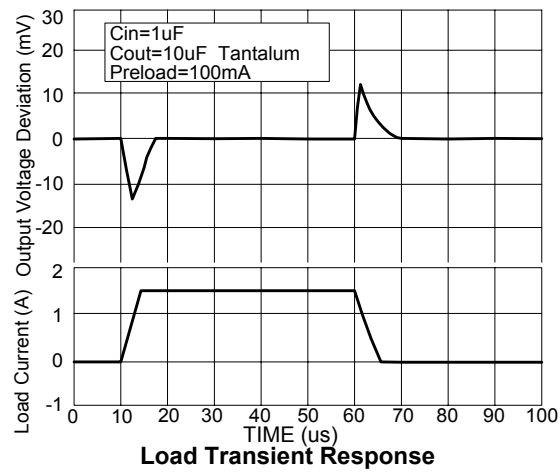
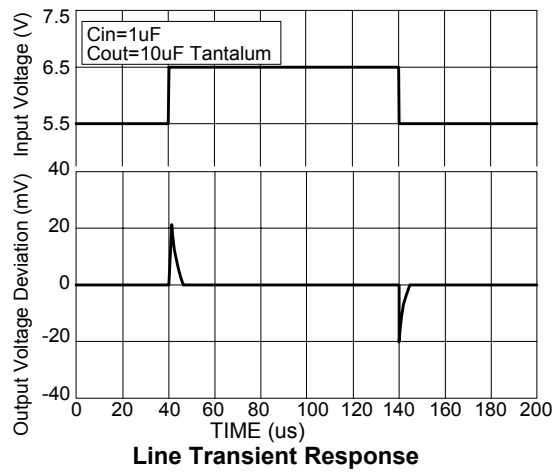
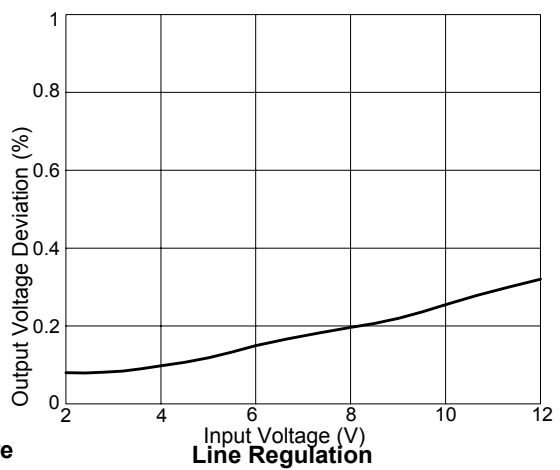
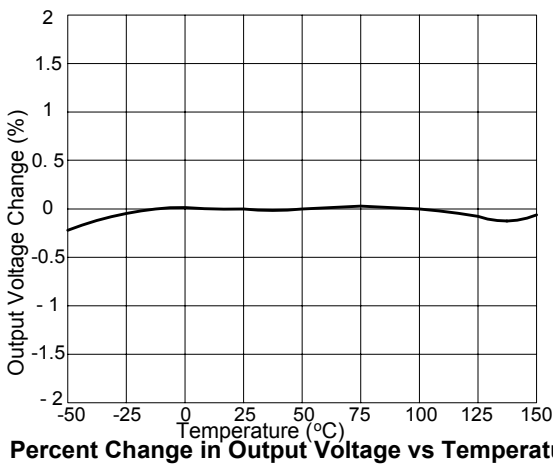
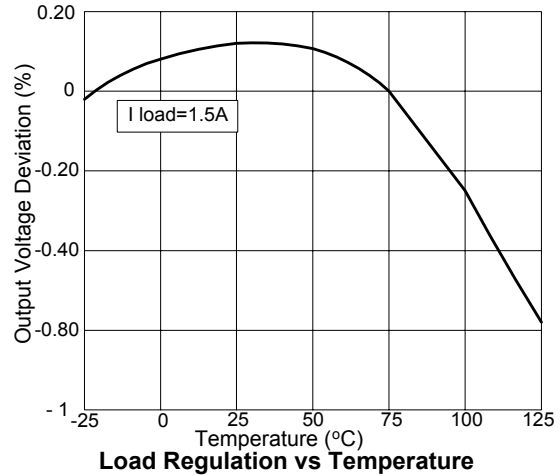
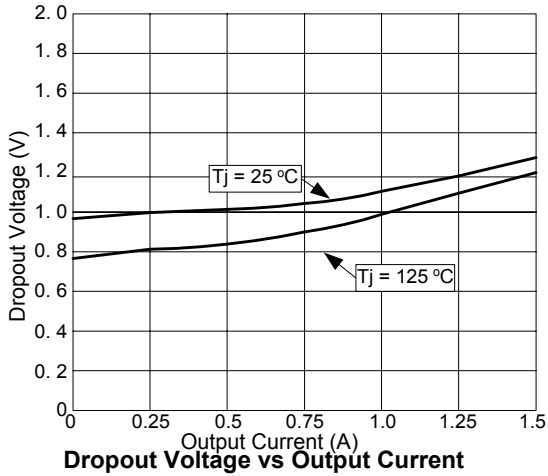



1.5A Low Dropout Positive Adjustable or Fixed-Mode Regulator

■ Marking Information

