



ULTRA LOW OUTPUT VOLTAGE LINEAR N-FET CONTROLLER

FEATURES

- Low ESR Output Capacitor (MLCC and POSCAP) Applicable
- 0.5V Reference Voltage with 2% Accuracy
- Internal Soft-Start
- Enable Control
- Under-Voltage Short Circuit Protection
- Fast Transient Response
- Power OK Output with a Delay Time
- Adjustable Output Voltage Down to 0.5V
- Drive N-Channel MOSFETs
- Halogen Free & RoHS Compliant

DESCRIPTION

The APE8858 is an ultra low output voltage linear N-FET controller. This product is specifically designed to provide well supply voltage for front-side-bus termination on motherboards and NB applications. The APE8858 integrates many functions. A Power-On-Reset (POR) circuit monitors supply voltages to prevent wrong operations. A POK indicates the output status with time delay which is set internally. It can control other converter for power sequence. The APE8858 can be enabled by other power system.

A 0.5V reference voltage with 2% accuracy provide tight regulation of the output voltage, enable control, open drain power good signal, under-voltage protection and soft start.

TYPICAL APPLICATION

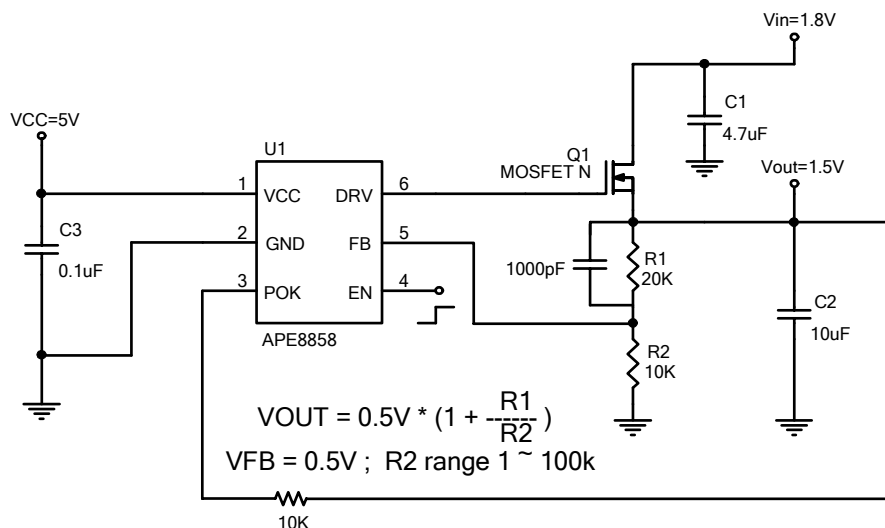

ORDERING INFORMATIO

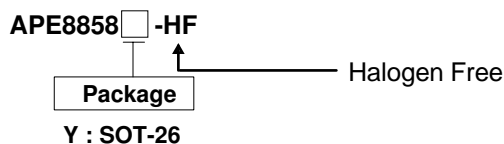



ABSOLUTE MAXIMUM RATINGS (at $T_A=25^\circ\text{C}$)

VCC	-0.3V to 7V
DRV to GND	-0.3V to VCC+0.3V
Power Dissipation (SOT-26)	0.4W
Storage Temperature Range	-65 to 150°C
Operating Temperature Range	-40 to 85°C
Junction Temperature Range	-40 to 125°C

PACKAGE INFORMATION

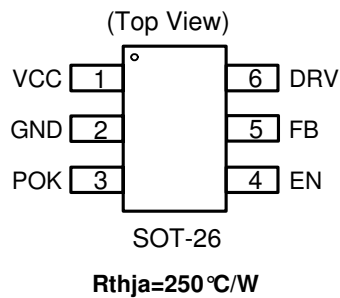

ELECTRICAL SPECIFICATIONS

($V_{IN}=1.5\text{V}$, $V_{SHDN}=V_{IN}$, $T_A=25^\circ\text{C}$, $C_{IN}=C_{OUT}=1\mu\text{F}$, unless otherwise noted.)

Parameter	SYM	TEST CONDITION	MIN	TYP	MAX	UNITS
Supply Voltage Range	V_{CC}		4.5	-	5.5	V
Input Voltage UVLO Threshold	V_{UVLO}	V_{CC} rising	-	3.75	-	V
Input Voltage UVLO Hysteresis	V_{HYST}	V_{CC} falling	-	0.25	-	V
Supply Current	I_{CC}	EN= V_{CC}	-	0.4	0.8	mA
Shutdown Current	I_{SD}	EN= 0V	-1	-	1	uA
Feedback Voltage	V_{FB}		0.49	0.5	0.51	V
Feedback Pin Input Current	I_{FB}	VFB =0.5V	-100	-	100	nA
Soft Start Time	TSS		-	1	-	ms
EN Pin Logic High threshold voltage	V_{ENH}	Enable	1.3	-	-	V
	V_{ENL}	Disable	-	-	0.5	
EN Pin Input Current	I_{EN}	$I_{OUT}=0\text{mA}$, $V_{IN}=5\text{V}$	-1	-	+1	uA
Output Voltage UVLO Threshold	$V_{TH(UV)}$	V_{FB} Falling	0.2	0.25	0.3	V
Ton Duty	T_{ON}	$V_{FB} < 0.25\text{V}$	-	30	-	%
DRV Output Current	$I_{DRV(SRC)}$	Sourcing, $V_{FB}=0.48\text{V}$	-	20	-	mA
	$I_{DRV(SINK)}$	Sinking, $V_{FB}=0.52\text{V}$	-	20	-	
DRV Pin Output Voltage	V_{DRV}	$V_{FB}=0.48\text{V}$, $V_{CC}=5\text{V}$, no load	4.9	-	5.0	V
POK Threshold Voltage for Power OK	V_{POK}	V_{FB} Rising	90%	93%	96%	VFB

ELECTRICAL SPECIFICATIONS(Cont.)

Parameter	SYM	TEST CONDITION	MIN	TYP	MAX	UNITS
POK Threshold Voltage for Power Not OK	V_{PNOK}	V_{FB} Falling	82%	85%	88%	VFB
POK Low Voltage		POK sinks 1mA	-	50	100	mV
POK Delay Time	T_{DELAY}		0.8	2	10	ms
Thermal Shutdown Temperature	TSD		-	150	-	°C
Thermal Shutdown Hysteresis			-	50	-	°C

PIN DESCRIPTIONS

PIN SYMBOL	PIN DESCRIPTION
FB	Feedback Pin
GND	Common Ground Pin
DRV	Gate Drive to N-FET
POK	Power ok Output Pin
EN	H : Normal Operation L : Shutdown
VCC	Input Voltage

BLOCK DIAGRAM

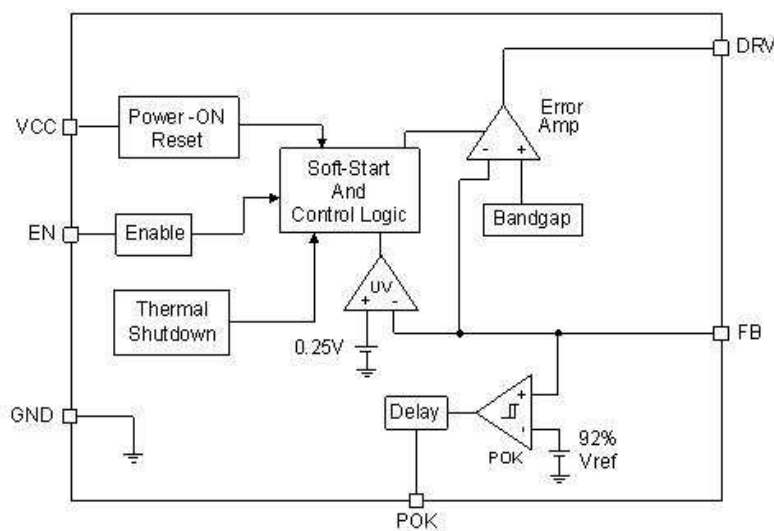



FUNCTION DESCRIPTIONS

Power-On-Reset

A Power-On-Reset (POR) circuit monitors input voltages at VCC pins to prevent wrong logic controls. The POR function initiates a soft-start process after the supply voltages exceed the rising POR threshold voltages during powering on. The POR function also pulls low the POK pin regardless the output voltage when the VCC voltage falls below its falling POR threshold.

Internal Soft-Start

An internal soft-start function controls rise rate of the output voltage to limit the current surge at start-up. The typical soft-start interval is about 1ms.

Output Voltage Regulation

An error amplifier working with a temperature compensated 0.5V reference and an output NMOS regulates output to the preset voltage. The error amplifier designed with high bandwidth and DC gain provides very fast transient response and less load regulation.

Under-Voltage Protection (UVP)

APE8858 monitors the voltage on FB pin after soft-start process is finished. Therefore the UVP is disabling during soft-start. When the voltage on FB pin falls below the under-voltage threshold, the UVP circuit shuts off the output immediately. After a while (~ 70% Duty) , APE8858 starts a new soft-start to regulate output.

Thermal Shutdown

A thermal shutdown circuit limits the junction temperature of APE8858. When the junction temperature exceeds +150°C, a thermal sensor turns off the output NMOS, allowing the device to cool down. The regulator regulates the output again through initiation of a new soft-start cycle after the junction temperature cools by 50°C, resulting in a pulsed output during continuous thermal overload conditions.



TYPICAL CHARACTERISTICS

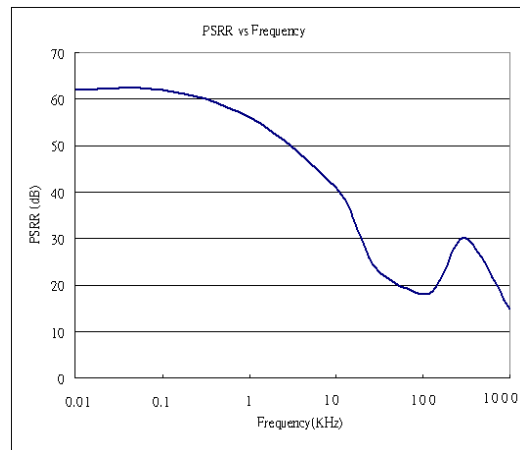
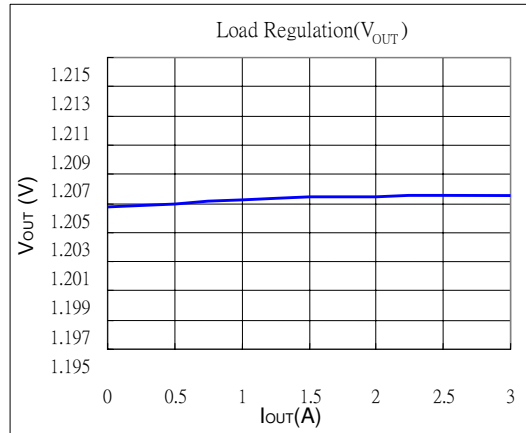
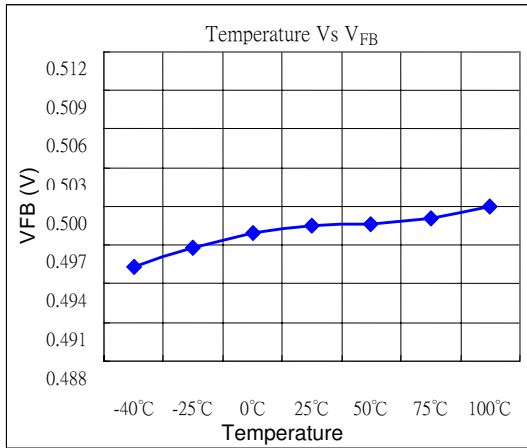



Package Outline : SOT-26

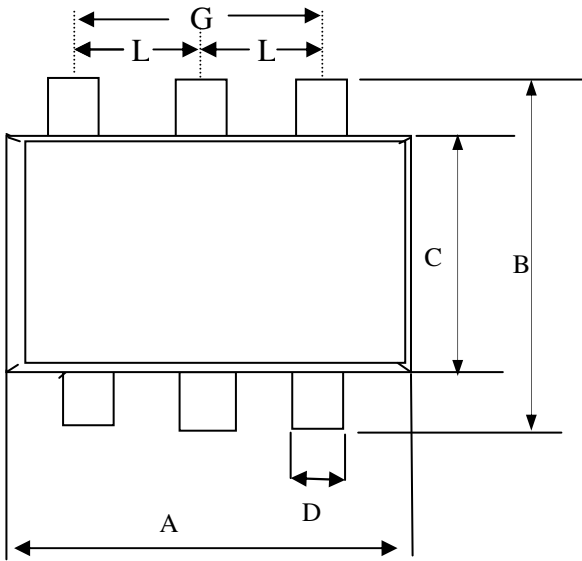

SYMBOLS	Millimeters		
	MIN	NOM	MAX
A	2.70	2.90	3.10
B	2.60	2.80	3.00
C	1.40	1.60	1.80
D	0.30	0.43	0.55
E	0.00	0.05	0.10
H	1.20REF		
G	1.90REF		
I	0.12REF		
J	0.37REF		
L	0.95REF		

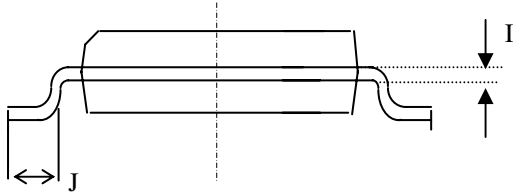
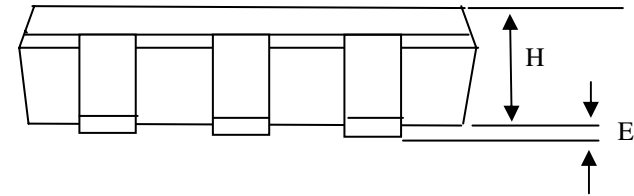

- 1.All Dimension Are In Millimeters.
- 2.Dimension Does Not Include Mold Protrusions.

Part Marking Information & Packing : SOT-26

