



32V,1A STEP-DOWN HIGH BRIGHTNESS LED DRIVER WITH 5000:1 DIMMING

GENERAL DESCRIPTION

The APE1630 is a continuous conduction mode inductive step-down converter, designed for driving single or multiple series connected LED efficiently from a voltage source higher than the total LED chain voltage. The device operates from an input supply between 8V and 32V and provides an externally adjustable output current of up to 1A. Depending upon the supply voltage and external components, the APE1630 can provide more than 15 watts of output power. The APE1630 includes the power switch and a high-side output current sensing circuit, which uses an external resistor to set the nominal average output current, and a dedicated DIM input accepts a wide range of pulsed dimming. Applying a voltage of 0.3V or lower to the DIM pin turns the output off and switches the device into a low current standby state.

The APE1630 is available in SOT-89-5L package.

FEATURES

- Simple Low Parts Count
- Wide Input Voltage Range: 8V to 32V
- Up to 1A Output Current
- Single Pin On/Off and Brightness Control Using PWM
- Up to 1MHz Switching Frequency
- Typical 5% Output Current Accuracy
- High-Side Current Sense
- Hysteretic Control: No Compensation
- Adjustable Constant LED Current



BLOCK DIAGRAM

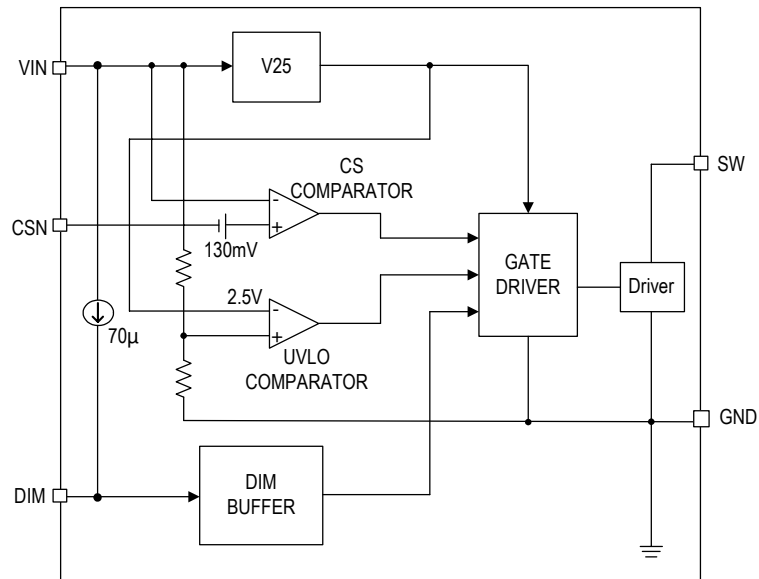

PIN ASSIGNMENT

The package of APE1630 is SOT-89-5L; the pin assignment is given by:

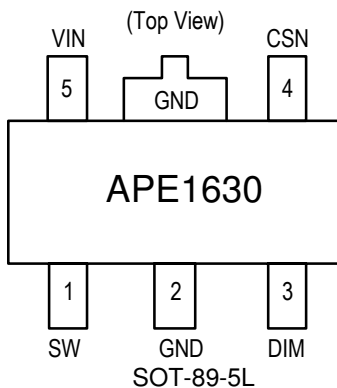

Name	Description
SW	Switch Output. SW is the output of the internal driver switch.
GND	Signal and power ground. Connect directly to ground plane.
DIM	Logic level dimming input. Drive DIM low to turn off the current regulator. Drive DIM high to enable the current regulator.
CSN	Current sense input
VIN	Input Supply Pin. Must be locally bypassed.

ORDER/MARKING INFORMATION

Order Information	Top Marking
<p>APE1630X</p> <p>└───┬───┘</p> <p>└───┬───┘</p> <p>Package Type</p> <p>G5 : SOT-89-5L</p>	<p>1630 → Part number</p> <p>YWX → ID code: internal</p> <p>└───┬───┘</p> <p>└───┬───┘</p> <p>└───┬───┘</p> <p>WW: 01~26 (A~Z)</p> <p>27~52 (a~z)</p> <p>Year: A=2010</p> <p>1=2011</p>



ABSOLUTE MAXIMUM RATINGS (at $T_A=25^\circ\text{C}$)

Characteristics	Symbol	Rating	Unit
Supply Voltage	V_{IN}	-0.3 to 40	V
Driver Output Voltage	SW	-0.3 to 40	V
Current Sense Input (Respect to V_{IN})	CSN	+0.3 to (-6.0)	V
Logic Level Dimming Input	DIM	-0.3 to +6	V
Switch Output Current	I_{SW}	1.2	A
Power Dissipation	P_{DMAX}	1.5	W
Operation Junction Temperature Range	T_J	-40 to 125	$^\circ\text{C}$
Storage Temperature	T_{STG}	-55 to 150	$^\circ\text{C}$
Thermal Resistance from Junction to Case	θ_{JC}	15	$^\circ\text{C/W}$
Thermal Resistance from Junction to Ambient	θ_{JA}	50	$^\circ\text{C/W}$

Note: θ_{JA} is measured with the PCB copper are (need connect to tap) of approximately 1 in² (Multi-layer).

ELECTRICAL CHARACTERISTICS

The following specifications apply for $V_{IN} = 12\text{V}$, $T_A=25^\circ\text{C}$, unless specified otherwise.

Characteristics	Symbol	Conditions	Min	Typ	Max	Units
Input Voltage	V_{IN}		8	-	32	V
Under Voltage Lock Out	V_{UVLO}	V_{IN} rising	-	7	-	V
UVLO Hysteresis	V_{UVLO_hys}	V_{IN} falling	-	1000	-	mV
Max. Switching Frequency	F_{SW}		-	-	1	MHz
Current Sense						
Mean Current Sense Threshold Voltage	V_{CSN}	$V_{IN}-V_{CSN}$	120	130	140	mV
Sense Threshold Hysteresis	V_{CSN_hys}		-	± 15	-	%
CSN Pin Input Current	I_{CSN}	$V_{IN}-V_{CSN} = 50\text{mV}$	-	0.5	-	μA
DIM Input						
DIM Input Voltage High	V_{DIM_H}		2.0	-	-	V
DIM Input Voltage Low	V_{DIM_L}		-	-	0.3	V
Max. DIM Frequency	f_{DIM}	$f_{OSC} = 500\text{kHz}$	-	-	50	kHz
Duty Cycle Range of Low Frequency Dimming	D_{PWM_LF}	$f_{DIM} = 100\text{Hz}$	0.02%	-	1	
Brightness Control Range			-	5000:1	-	



Duty Cycle Range of High Frequency Dimming	D _{PWM_HF}	f _{DIM} = 20kHz	4%	-	1	
Brightness Control Range			-	25:1	-	
DIM Pull up Resistor to Internal Supply Voltage	R _{DIM}		-	300	-	KΩ
DIM Input Leakage Low	I _{DIM_L}	V _{DIM} = 0	-	70	-	μA
Output Switch						
Saturation Voltage	V _{SAT}	I _{OUT} = 0.3A	-	0.8	1.0	V
Saturation Voltage	V _{SAT}	I _{OUT} = 0.8A	-	1.0	1.2	V
Continuous SW Current	I _{SWmean}		-	-	1.0	A
SW Leakage Current	I _{LEAK}		-	0.5	5	μA
Thermal Shutdown						
Thermal Shutdown Threshold	T _{SD}		-	150	-	°C
Thermal Shutdown hysteresis	T _{SD-hys}		-	35	-	°C

APPLICATION CIRCUIT

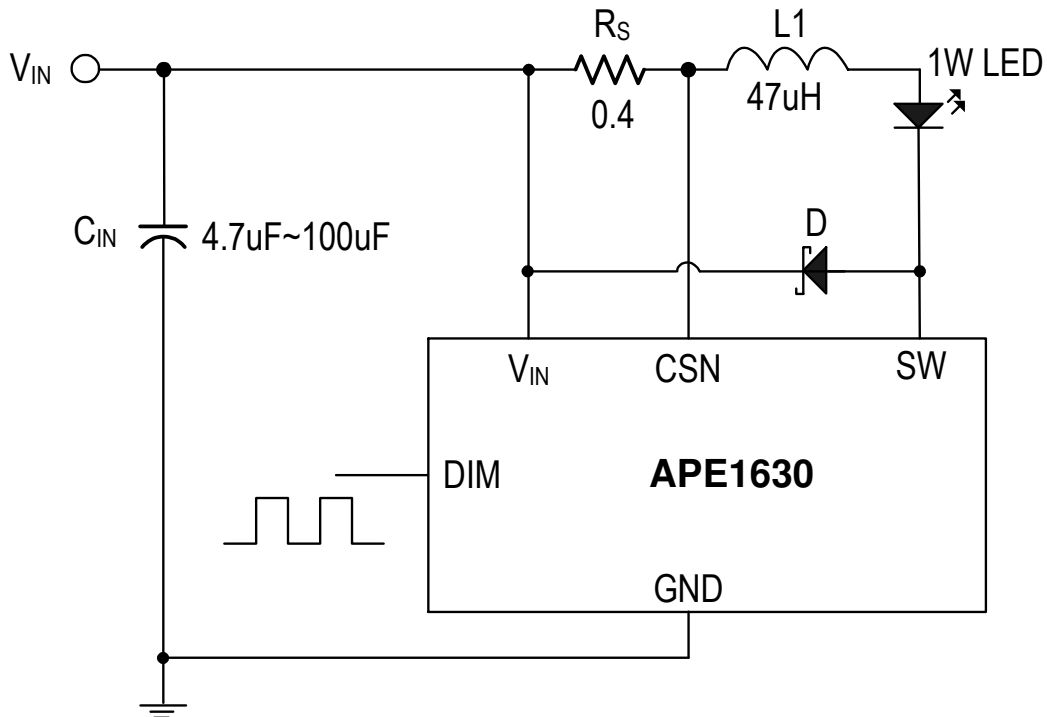

$$I_{LED} = \frac{V_{CSN}}{R_s} = \frac{0.130}{0.4} = 0.325A$$



APPLICATION INFORMATION

OPERATION DESCRIPTION

The device, in conjunction with the coil (L1) and current sense resistor (R_S), forms a self oscillating continuous-mode buck converter.

When input voltage V_{IN} is first applied, the initial current in L1 and R_S is zero and there is no output from the current sense circuit. Under this condition, the output of CS comparator is high. This turns on an internal switch and switches the SW pin low, causing current to flow from V_{IN} to ground, via R_S , L1 and the LED(s). The current rises at a rate determined by V_{IN} and L1 to produce a voltage ramp (V_{CSN}) across R_S . When $(V_{IN}-V_{CSN}) > 150\text{mV}$, the output of CS comparator switches low and the switch turns off. The current flowing on the R_S decreases at another rate. When $(V_{IN}-V_{CSN}) < 110\text{mV}$, the switch turns on again and the mean current on the LED is determined by $(\frac{110 + 150}{2} \text{ mV}) / R_S = 130\text{mV} / R_S$.

The high-side current-sensing scheme and on-board current-setting circuitry minimize the number of external components while delivering LED current with $\pm 5\%$ accuracy, using a 1% sense resistor.

The APE1630 allow dimming with a PWM signal at the DIM input. A logic level below 0.3V at DIM forces APE1630 to turn off the LED and the logic level at DIM must be at least 2.0V to turn on the full LED current. The frequency of PWM dimming ranges from 100Hz to more than 20 kHz.

The DIM pin is pulled high current approximately 70 μA . It can be floated at normal working. When a voltage applied to DIM falls below the threshold (0.3V nom.), the output switch is turned off. The internal regulator and voltage reference remain powered during shutdown to provide the reference for the shutdown circuit.

Additionally, to ensure the reliability, the APE1630 is built with a thermal shutdown (TSD) protection and a thermal pad. The TSD protects the IC from over temperature (150°C). Also the thermal pad enhances power dissipation. As a result, the APE1630 can handle a large amount of current safely.

Setting nominal average output current with external resistor R_S

The nominal average output current in the LED(s) is determined by the value of the external current sense resistor (R_S) connected between V_{IN} and CSN and is given by:

$$I_{OUT} = 0.130/R_S (R_S \geq 0.16\Omega)$$

This equation is valid when DIM pin is float. Actually, R_S sets the maximum average current which can be adjusted to a less one by dimming.



Output current adjustment by PWM control

A Pulse Width Modulated (PWM) signal with duty cycle PWM can be applied to the DIM pin, as shown below, to adjust the output current to a value below the nominal average value set by resistor R_s :

$$I_{OUT} = \frac{0.1 \times D}{R_s}$$

$(0 \leq D \leq 100\%, 0.3V < V_{pulse} < 2.5V)$

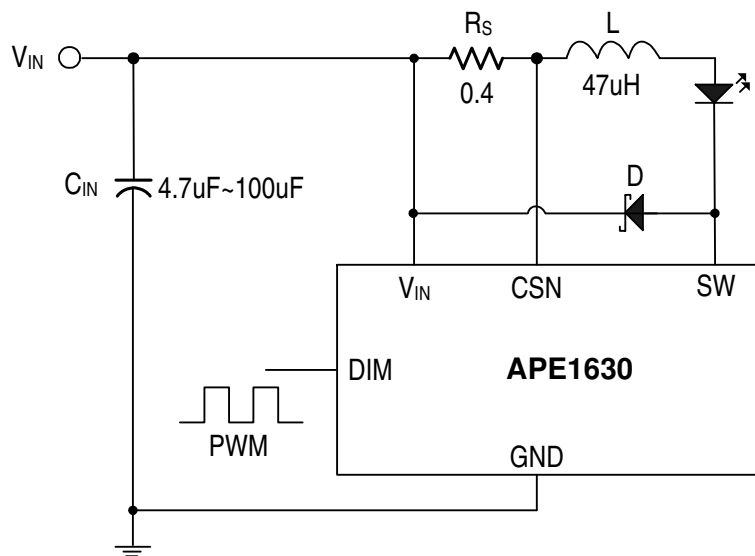

PWM dimming provides reduced brightness by modulating the LED's forward current between 0% and 100%. The LED brightness is controlled by adjusting the relative ratios of the on time to the off time. A 25% brightness level is achieved by turning the LED on at full current for 25% of one cycle. To ensure this switching process between on and off state is invisible by human eyes, the switching frequency must be greater than 100 Hz. Above 100 Hz, the human eyes average the on and off times, seeing only an effective brightness that is proportional to the LED's on-time duty cycle. The advantage of PWM dimming is that the forward current is always constant; therefore the LED color does not vary with brightness as it does with analog dimming. Pulsing the current provides precise brightness control while preserving the color purity. The dimming frequency of APE1630 can be as high as 20 kHz.

Shutdown mode

Taking the DIM pin to a voltage below 0.3V will turn off the output and the supply current will fall to a low standby level of 70µA nominal.



Capacitor selection

A low ESR capacitor should be used for input decoupling, as the ESR of this capacitor appears in series with the supply source impedance and lowers overall efficiency. This capacitor has to supply the relatively high peak current to the coil and smooth the current ripple on the input supply. A minimum value of 4.7 μ F is acceptable if the input source is close to the device, but higher values will improve performance at lower input voltages, especially when the source impedance is high. The input capacitor should be placed as close as possible to the IC.

For maximum stability over temperature and voltage, capacitors with X7R, X5R, or better dielectric are recommended. Capacitors with Y5V dielectric are not suitable for decoupling in this application and should not be used.

Inductor selection

Recommended inductor values for the APE1630 are in the range 47 μ H to 120 μ H. Higher values of inductance are recommended at lower output current in order to minimize errors due to switching delays, which result in increased ripple and lower efficiency. Higher values of inductance also result in a smaller change in output current over the supply voltage range. The inductor should be mounted as close to the device as possible with low resistance connections to the SW and V_{IN} pins.

Diode selection

For maximum efficiency and performance, the rectifier (D1) should be a fast low capacitance Schottky diode with low reverse leakage at the maximum operating voltage and temperature.

They also provide better efficiency than silicon diodes, due to a combination of lower forward voltage and reduced recovery time.

It is important to select parts with a peak current rating above the peak coil current and a continuous current rating higher than the maximum output load current. It is very important to consider the reverse leakage of the diode when operating above 85°C. Excess leakage will increase the power dissipation in the device and if close to the load may create a thermal runaway condition.

The higher forward voltage and overshoot due to reverse recovery time in silicon diodes will increase the peak voltage on the SW output. If a silicon diode is used, care should be taken to ensure that the total voltage appearing on the SW pin including supply ripple, does not exceed the specified maximum value.



Reducing output ripple

Peak to peak ripple current in the LED(s) can be reduced, if required, by shunting a capacitor C_{LED} across the LED(s) as shown below:

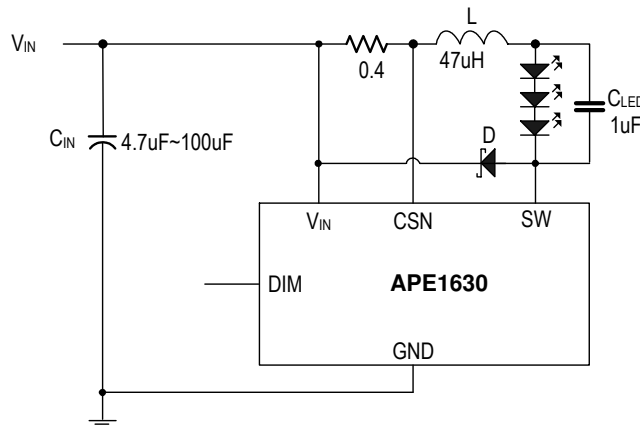

A value of 1uF will reduce the supply ripple current by a factor three (approx.). Proportionally lower ripple can be achieved with higher capacitor values. Note that the capacitor will not affect operating frequency or efficiency, but it will increase start-up delay and reduce the frequency of dimming, by reducing the rate of rise of LED voltage.

By adding this capacitor the current waveform through the LED(s) changes from a triangular ramp to a more sinusoidal version without altering the mean current value.

Operation at low supply voltage

The internal regulator disables the drive to the switch until the supply has risen above the startup threshold (V_{UVLO}). Above this threshold, the device will start to for this reason, the temperature coefficients of the operating. However, with the supply voltage below the specified minimum value, the switch duty cycle will be high and the device power dissipation will be at a maximum. Care should be taken to avoid operating the device under such conditions in the application, in order to minimize the risk of exceeding the maximum allowed die temperature. (See next section on thermal considerations). The drive to the switch is turned off when the supply voltage falls below the under-voltage threshold ($V_{UVLO}-1V$).

This prevents the switch working with excessive 'on' resistance under conditions where the duty cycle is high.

Thermal shutdown protection

To ensure the reliability, the APE1630 is built with a thermal shutdown (TSD) protection function. The TSD protects the IC from over temperature ($150^{\circ}C$). When the chip temperature decreases ($115^{\circ}C$), the IC recovers again.



TYPICAL CHARACTERISTICS

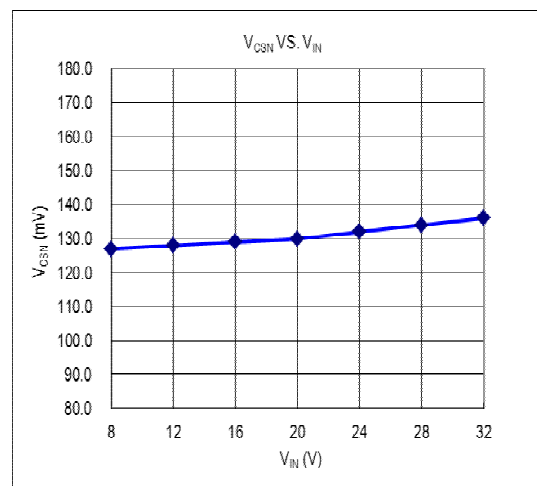
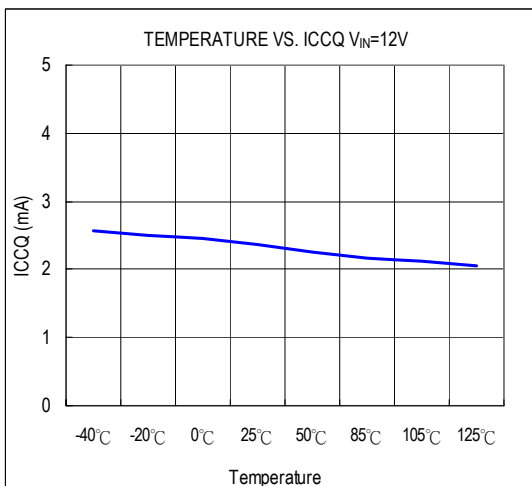
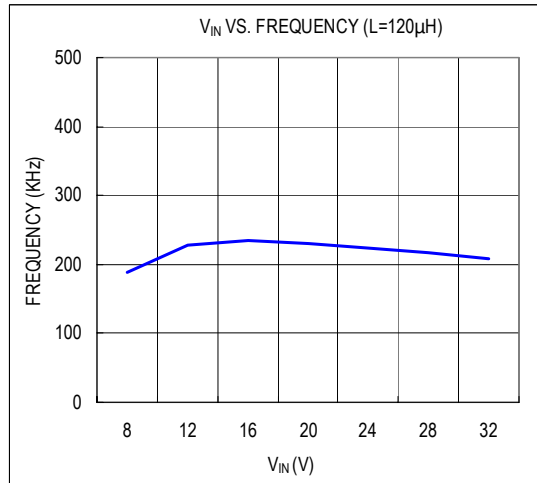
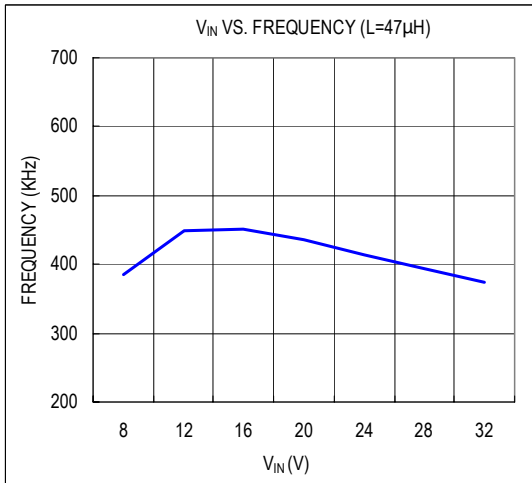
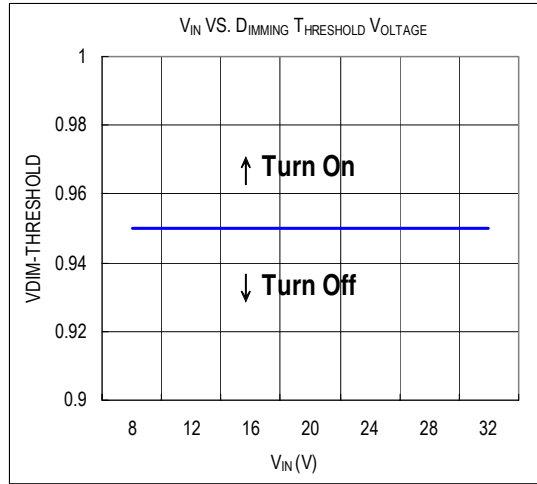
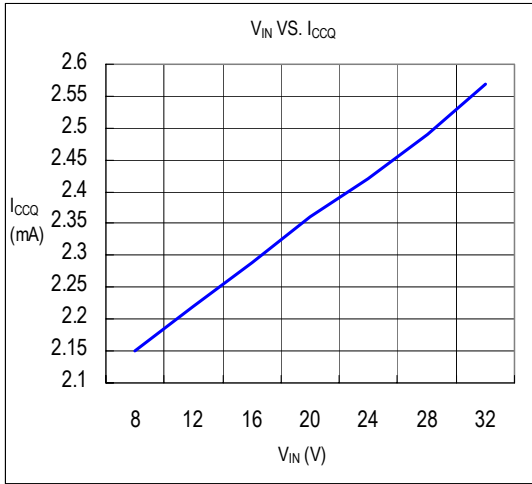



TYPICAL CHARACTERISTICS (CONTINUOUS)

50KHz Dimming $V_{IN}=32V$

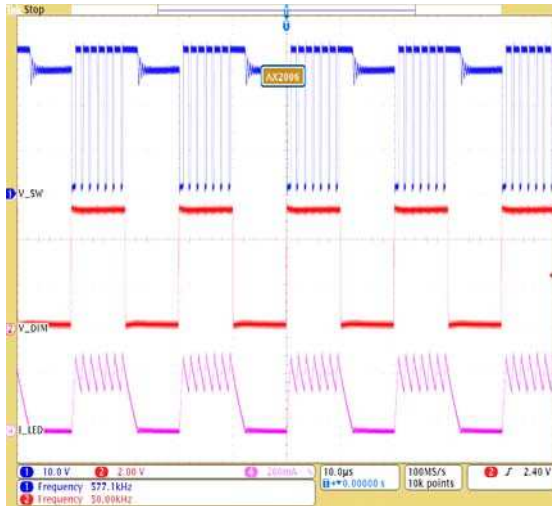

50KHz Dimming $V_{IN}=12V$

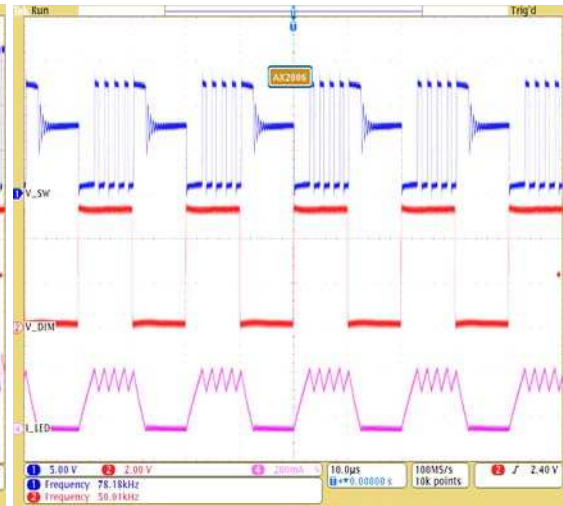

1KHz Dimming

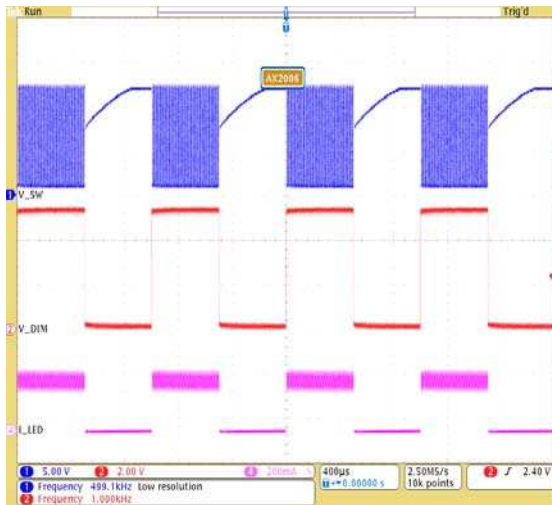



PACKAGE OUTLINES

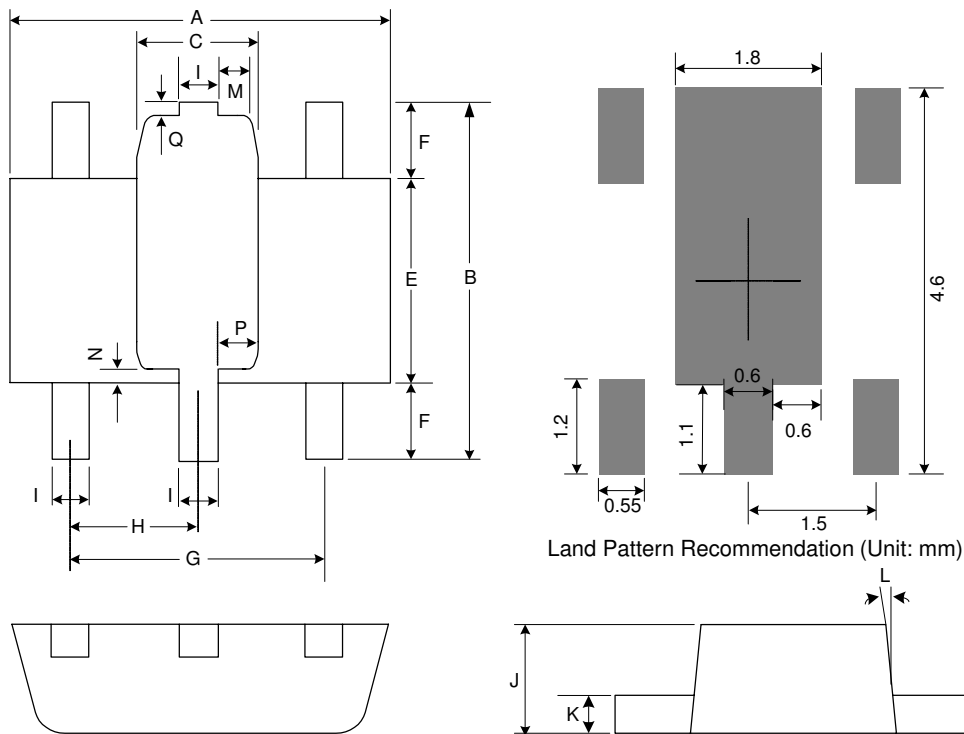

Symbol	Dimensions in Millimeters			Dimensions in Inches		
	Min.	Nom.	Max.	Min.	Nom.	Max.
A	4.30	4.50	4.70	0.169	0.177	0.185
B	4.05	4.15	4.25	0.159	0.163	0.167
C	1.40	1.70	2.00	0.055	0.067	0.079
E	2.30	2.50	2.70	0.091	0.098	0.106
F	0.80	0.90	1.00	0.031	0.035	0.039
G	3.00 REF.			0.118 REF.		
H	1.50 REF.			0.059 REF.		
I	0.40	0.46	0.52	0.016	0.018	0.020
J	1.40	1.50	1.60	0.055	0.059	0.063
K	0.35	0.39	0.43	0.014	0.015	0.017
L	5° TYP.			5° TYP.		
M	0.43	0.47	0.51	0.017	0.019	0.020
N	0.15	0.18	0.21	0.006	0.007	0.008
P	0.51	0.57	0.63	0.020	0.022	0.025
Q	0.13	0.16	0.19	0.005	0.006	0.007