

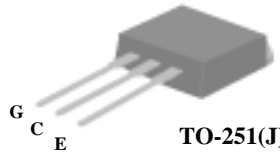

Description

- * High Input Impedance
- * High Pick Current Capability
- * 4.5V Gate Drive
- * Strobe Flash Applications

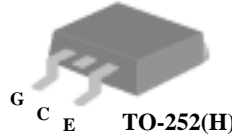

V_{CES}	450V
I_{CP}	130A

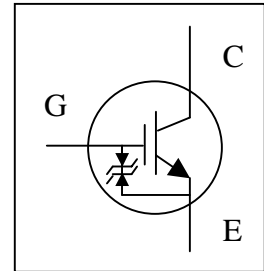

Absolute Maximum Ratings

Symbol	Parameter	Rating	Units
V_{CES}	Collector-Emitter Voltage	450	V
V_{GE}	Gate-Emitter Voltage	± 6	V
I_{GEP}	Pulsed Gate-Emitter Voltage	± 8	V
I_{CP}	Pulsed Collector Current	130	A
$P_D @ T_C=25^\circ C$	Maximum Power Dissipation	20	W
T_{STG}	Storage Temperature Range	-55 to 150	$^\circ C$
T_J	Operating Junction Temperature Range	-55 to 150	$^\circ C$

Electrical Characteristics @ $T_J=25^\circ C$ (unless otherwise specified)

Symbol	Parameter	Test Conditions	Min.	Typ.	Max.	Units
I_{GES}	Gate-Emitter Leakage Current	$V_{GE}=6V, V_{CE}=0V$	-	-	10	μA
I_{CES}	Collector-Emitter Leakage Current ($T_J=25^\circ C$)	$V_{CE}=450V, V_{GE}=0V$	-	-	10	μA
$V_{CE(sat)}$	Collector-Emitter Saturation Voltage	$V_{GE}=4.5V, I_{CP}=130A$ (Pulsed)	-	5	8	V
$V_{GE(th)}$	Gate Threshold Voltage	$V_{CE}=V_{GE}, I_C=250\mu A$	-	-	1.2	V
Q_g	Total Gate Charge	$I_C=40A$	-	51	-	nC
Q_{ge}	Gate-Emitter Charge	$V_{CE}=300V$	-	2	-	nC
Q_{gc}	Gate-Collector Charge	$V_{GE}=5V$	-	5.4	-	nC
$t_{d(on)}$	Turn-on Delay Time	$V_{CC}=200V$	-	5.5	-	ns
t_r	Rise Time	$I_C=40A$	-	72	-	ns
$t_{d(off)}$	Turn-off Delay Time	$R_G=25\Omega$	-	640	-	ns
t_f	Fall Time	$V_{GE}=5V$	-	2.6	-	us
C_{ies}	Input Capacitance	$V_{GE}=0V$	-	2095	-	pF
C_{oes}	Output Capacitance	$V_{CE}=25V$	-	145	-	pF
C_{res}	Reverse Transfer Capacitance	$f=1.0MHz$	-	35	-	pF
R_{thj-c}	Thermal Resistance Junction-Case		-	-	6	$^\circ C/W$



AP20G45EH/J

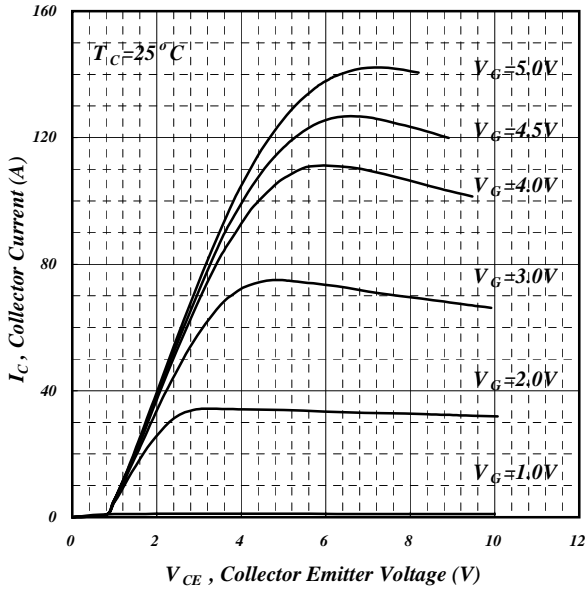

Fig 1. Typical Output Characteristics

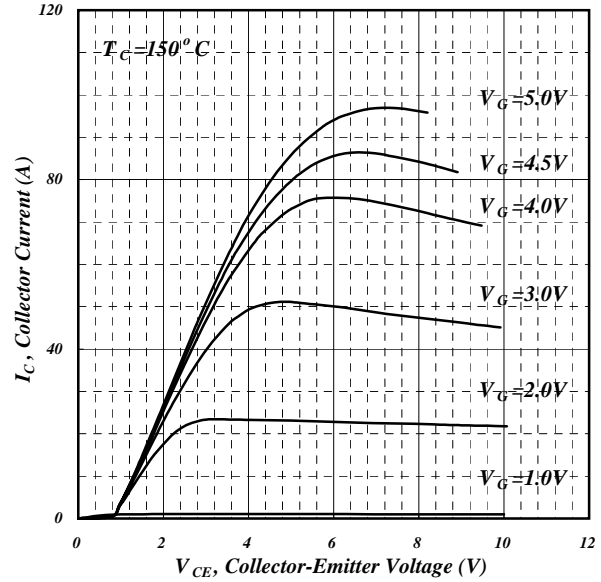

Fig 2. Typical Output Characteristics

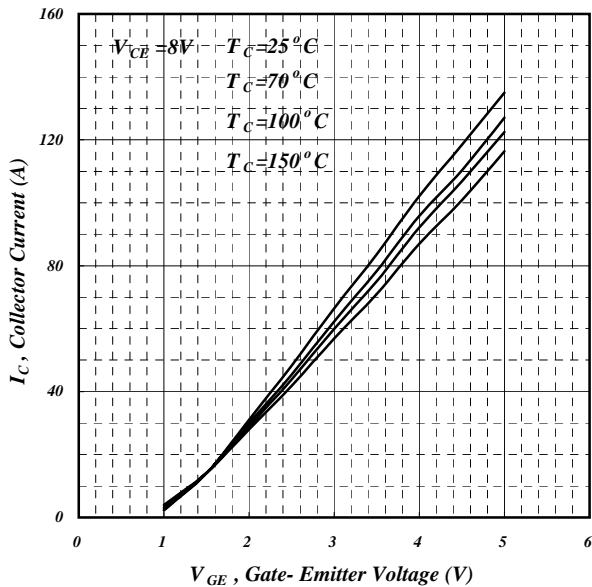

Fig 3. Collector Current v.s. Gate-Emitter Voltage

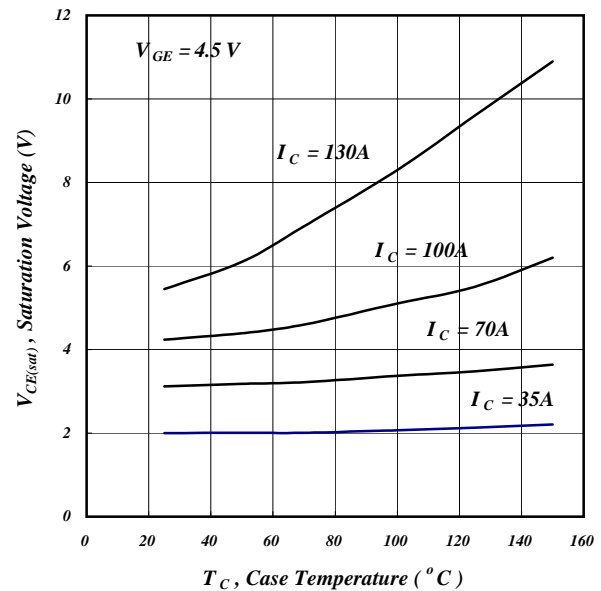

Fig 4. Collector-Emitter Saturation Voltage v.s. Case Temperature

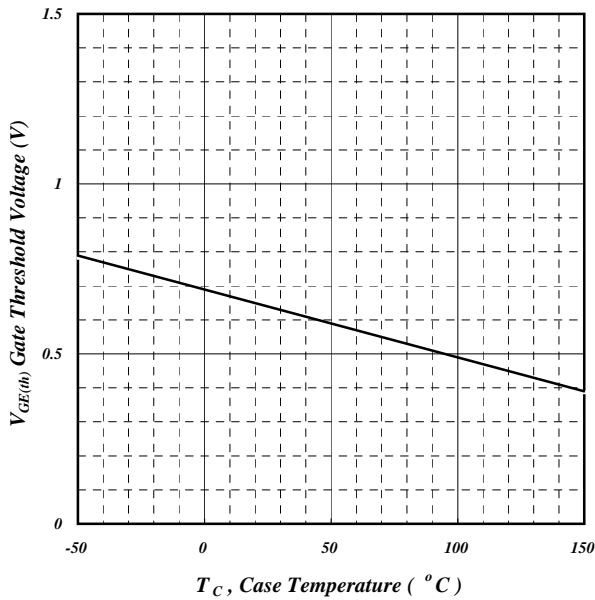

Fig 5. Gate-Emmitter Cut-Off Voltage v.s. Case Temperature

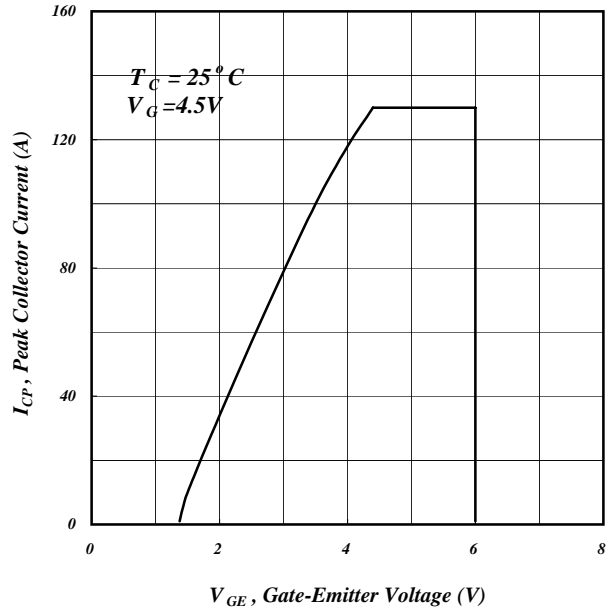

Fig 6. Safe Operation Area

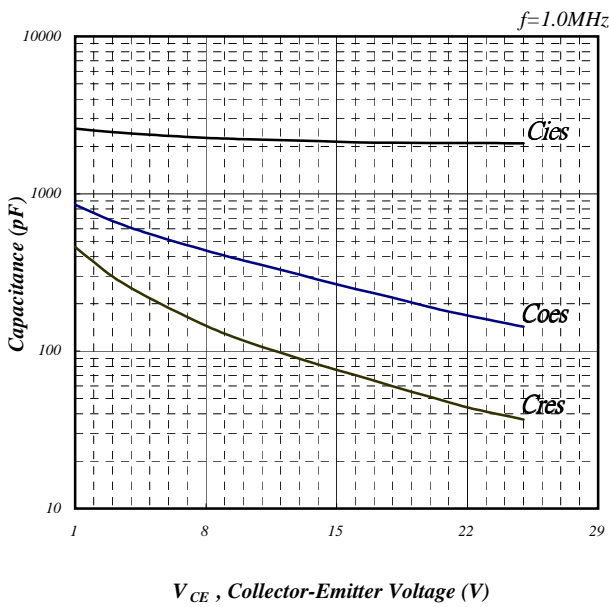

Fig 7. Collector v.s. Collector-Emmitter Voltage

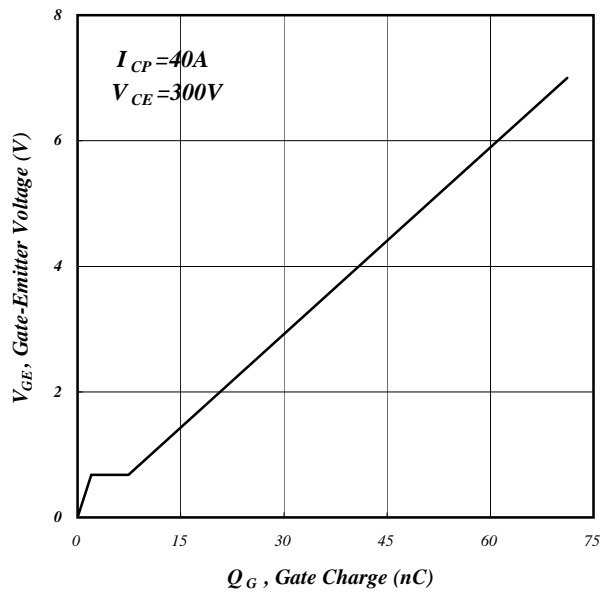

Fig 8. Gate Charge Waveform

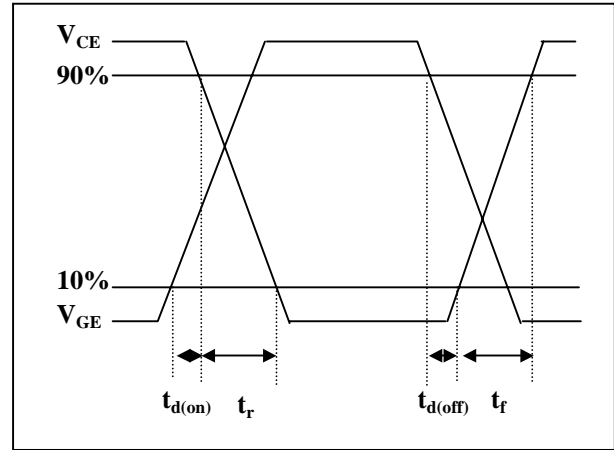
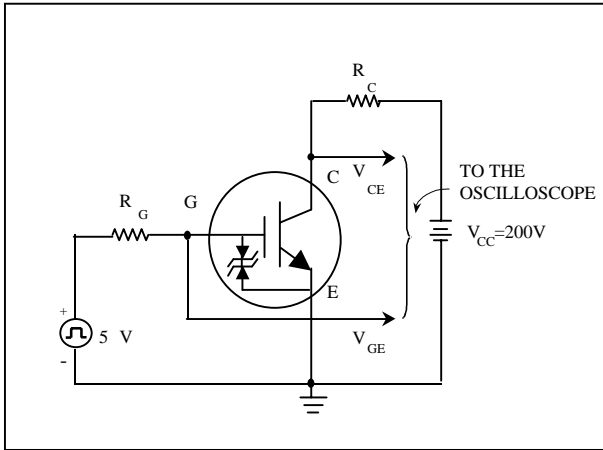

Fig 9. Switching Time Test Circuit

Fig 10. Switching Time Waveform

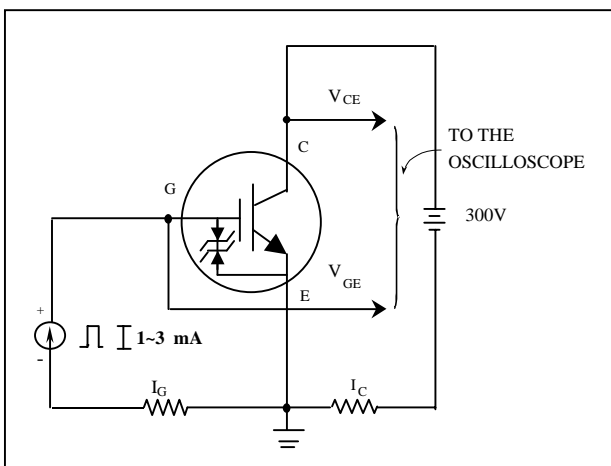

Fig 11. Gate Charge Test Circuit

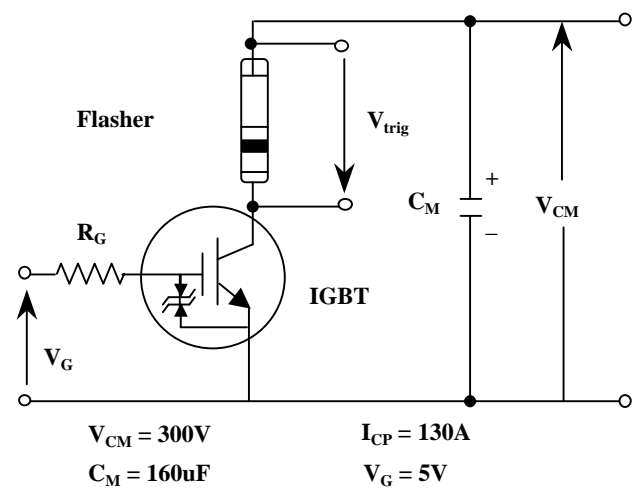

Fig 12. Application Test Circuit