



FEATURES

- 2.4V to 5.5V Battery Operation
- Chopper Stabilized Technology
- Micro Power Operation for Battery Applications
- Operation with North or South Pole
- High Sensitivity and High Stability of the Magnetic Switching Points
- 3-pin SOT-23 and Thin SOT-23 Package

DESCRIPTION

APE9103/A is a three-terminal Hall Effect sensor device with an output driver, mainly designed for battery-operation, hand-held equipment (such as Cellular and Cordless Phone, PDA). For APE9103, either North or South Pole of sufficient strength will turn the output on. The output will be turned off under no magnetic field. While the magnetic flux density (B) is larger than operate point (Bop), the output will be turned on (low), the output is latched until B is lower than release point (Brp), then turned off.

TYPICAL APPLICATION

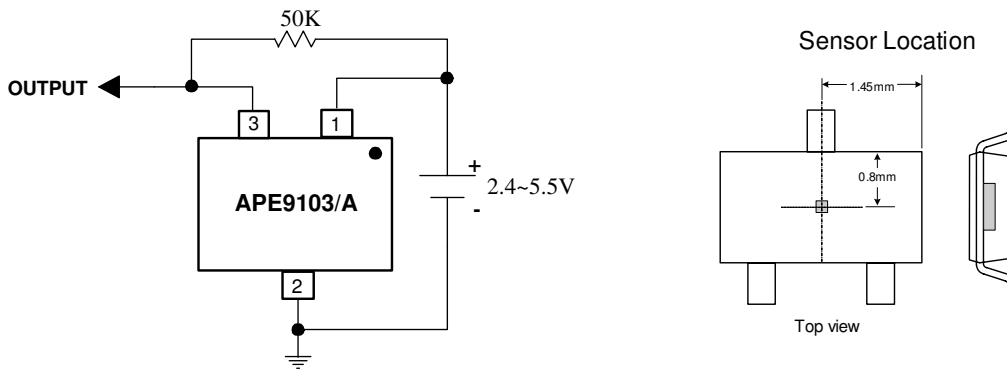

ORDERING INFORMATION

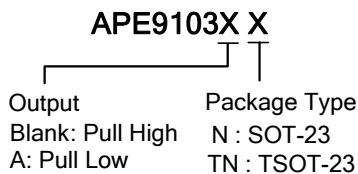



ABSOLUTE MAXIMUM RATINGS (at $T_A=25^\circ\text{C}$)

Supply Voltage (V_{DD})	-----	-0.3 to 6V
Output Voltage (V_{OUT})	-----	-0.3 to 6V
Output Current (I_{OUT})	-----	2mA
Power Dissipation(P_D)	-----	230mW
Storage Temperature Range(T_{ST})	-----	-65°C To 150°C
Operating Temperature Range(T_{OP})	-----	-40°C To 85°C
Junction Temperature(T_J)	-----	125°C
Thermal Resistance from Junction to Ambient(R_{thJA})		550°C/W

Note. R_{thJA} is measured with the PCB copper area of approximately 1 in² (Multi-layer).

PACKAGE INFORMATION

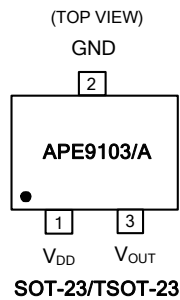

ELECTRICAL SPECIFICATIONS

($V_{DD}=2.75\text{V}$, $T_A=25^\circ\text{C}$, unless otherwise specified)

Parameter	SYM	TEST CONDITION	MIN	TYP	MAX	UNITS
Supply Voltage	V_{DD}		2.4	-	5.5	V
Input Current	I_{DD}	Awake State	-	2	4	mA
		Sleep State	-	7	12	uA
		Average	-	9	16	uA
Output Saturation Voltage	V_{OSAT}	$I_O=1\text{mA}$	-	0.1	0.3	V
Output Leakage Current	I_{O-LEAK}	$V_{OUT}=5.5\text{V}$, $B < Brp$	-	0.01	1	uA
Output Wake-Up Time	$T_{wake-up}$		-	70	120	us
Period	T_{Period}		-	70	120	ms
Duty Cycle			-	0.1	-	%



Magnetic Characteristics

($V_{DD} = 2.75V$, $T_A = 25^\circ C$, unless otherwise specified)

Parameter	SYM	TEST CONDITION	MIN	TYP	MAX	UNITS
Operating Points	B_{OPS}		-	35	55	Gauss
	B_{OPN}		-55	-35	-	
Release Points	B_{RPS}		10	25	-	
	B_{RPN}		-	-25	-10	
Hysteresis	B_{hys}		-	10	-	

1.APE9103

2.APE9103A

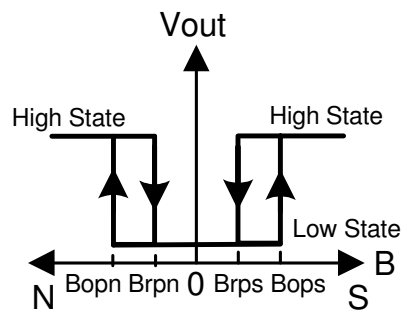
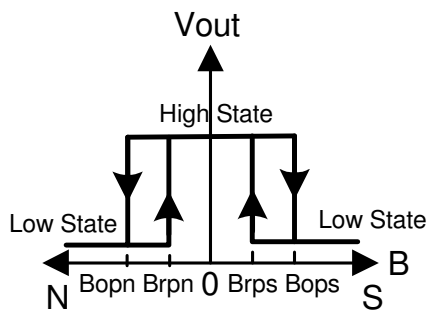

PIN DESCRIPTIONS

PIN SYMBOL	PIN DESCRIPTION
VDD	Power Input Pin
GND	Ground
OUTPUT	<p>APE9103</p> <p>$B > B_{ops}$ or $B < B_{opn}$, Output is Low.</p> <p>$B < B_{rps}$ or $B > B_{rpn}$, Output is High.</p> <p>APE9103A</p> <p>$B > B_{ops}$ or $B < B_{opn}$, Output is High.</p> <p>$B < B_{rps}$ or $B > B_{rpn}$, Output is Low.</p>

BLOCK DIAGRAM

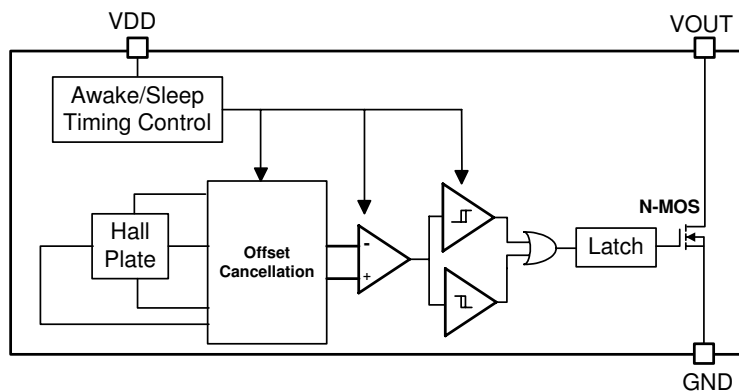



TYPICAL PERFORMANCE CHARACTERISTICS

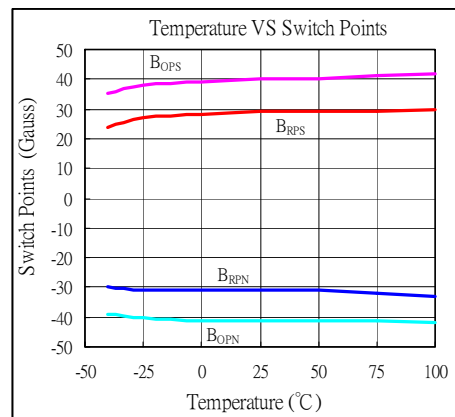
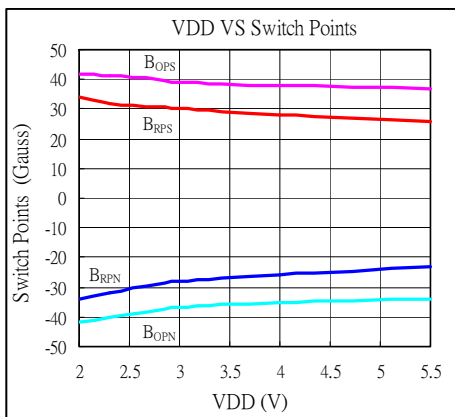
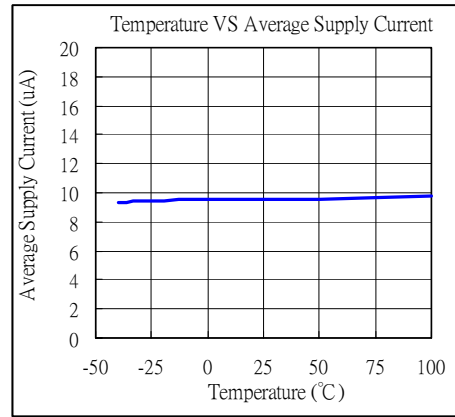
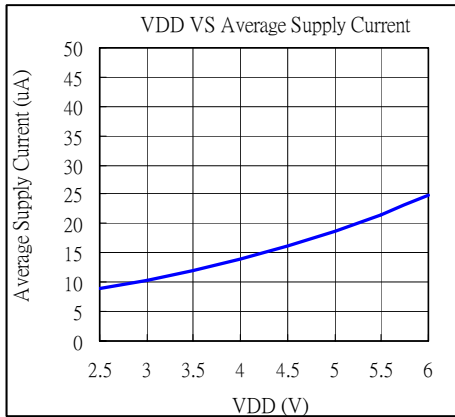



PACKAGE OUTLINES

(1) SOT-23-3L

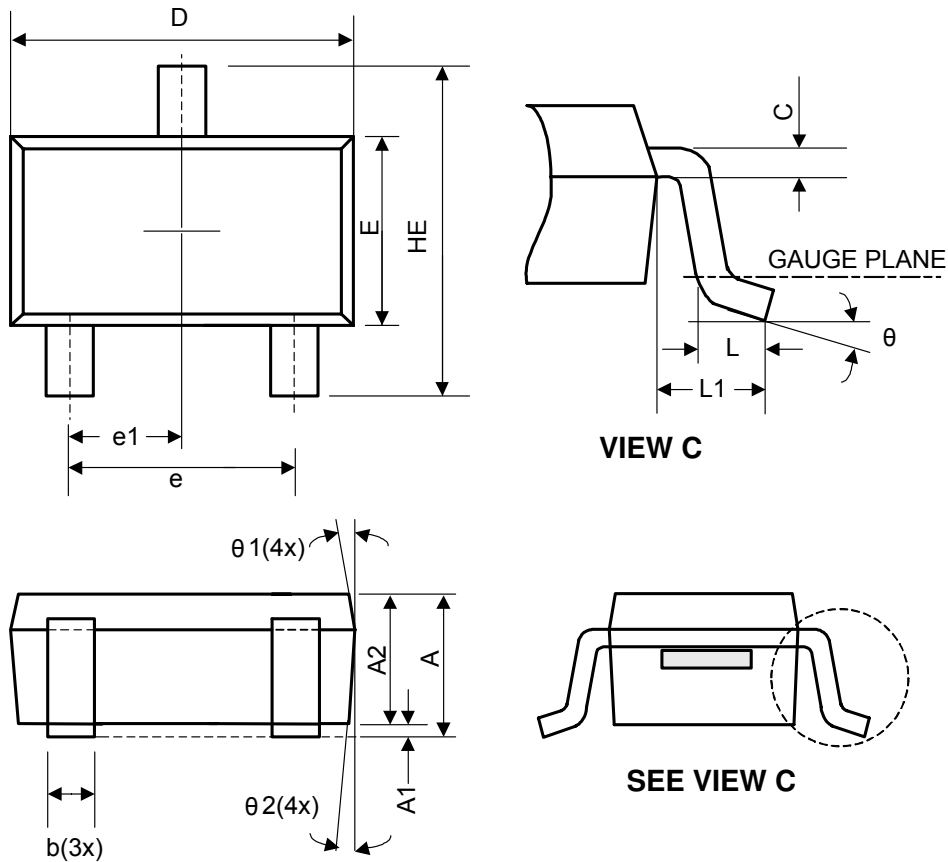

Symbol	Dimensions In Millimeters			Dimensions In Inches		
	Min.	Nom.		Min.	Nom.	
A	1.05	-	A	1.05	-	A
A1	0.05	-	A1	0.05	-	A1
A2	1.00	1.10	A2	1.00	1.10	A2
b	0.25	-	b	0.25	-	b
C	0.08	-	C	0.08	-	C
D	2.70	2.90	D	2.70	2.90	D
E	1.50	1.60	E	1.50	1.60	E
HE	2.60	2.80	HE	2.60	2.80	HE
L	0.30	-	L	0.30	-	L
L1	0.50	0.60	L1	0.50	0.60	L1
e	1.80	1.90	e	1.80	1.90	e
e1	0.85	0.95	e1	0.85	0.95	e1
theta	0°	5°	theta	0°	5°	theta
theta1	3°	5°	theta1	3°	5°	theta1
theta2	6°	8°	theta2	6°	8°	theta2

MARKING INFORMATION

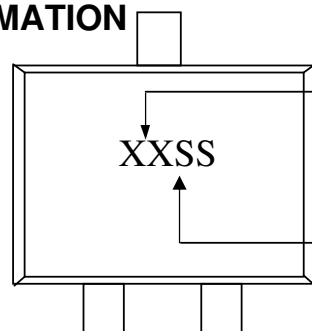

Part Number :

Z1 : APE9103
Z2 : APE9103A

Date Code :

SS:2004,2008,2012...
SS:2003,2007,2011...
SS:2002,2006,2010...
SS:2001,2005,2009...

"A~Z" showed on 3rd position --> week 1 ~ week 26,
"A~Z" showed on 4th position --> week 27 ~ week 52.



(2) TSOT-23-3L

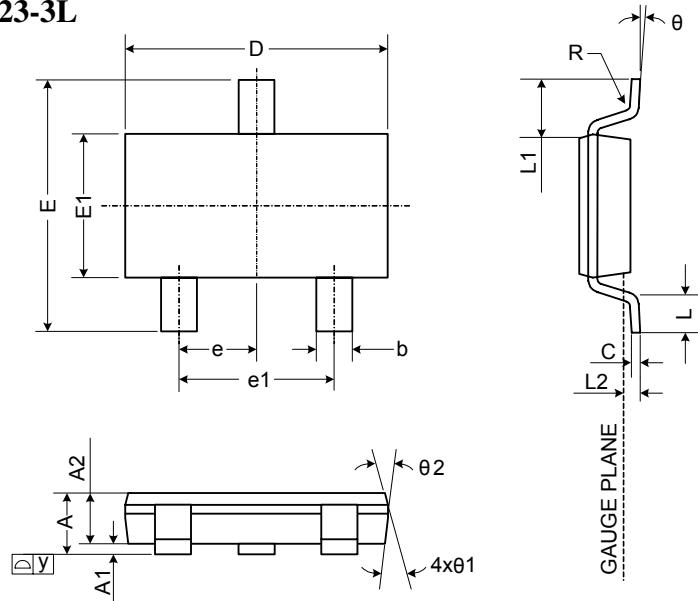

Symbol	Dimensions In Millimeters			Dimensions In Inches		
	Min.	Nom.	Max.	Min.	Nom.	Max.
A	0.75	-	0.90	0.030	-	0.035
A1	0.00	-	0.10	0.000	-	0.004
A2	0.70	0.75	0.80	0.028	0.030	0.031
b	0.35	-	0.51	0.014	-	0.020
C	0.10	-	0.25	0.004	-	0.010
D	2.80	2.90	3.00	0.110	0.114	0.118
E	2.60	2.80	3.00	0.102	0.110	0.118
E1	1.50	1.60	1.70	0.059	0.063	0.067
e	0.95 BSC.			0.037		
e1	1.90 BSC.			0.075		
L	0.37	-	-	0.015	-	-
L1	0.60 REF.			0.024		
L2	0.25 BSC.			0.010		
y	-	-	0.10	-	-	0.004
R	0.10	-	-	0.004	-	-
theta	0°	-	8°	0°	-	8°
theta1	7° NOM.			7° NOM.		
theta2	5° NOM.			5° NOM.		

MARKING INFORMATION

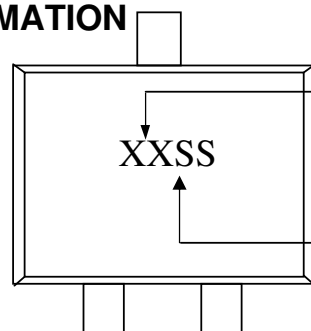

Part Number :

Z1 : APE9103
Z2 : APE9103A

Date Code :

SS:2004,2008,2012...
SS:2003,2007,2011...
SS:2002,2006,2010...
SS:2001,2005,2009...

"A~Z" showed on 3rd position --> week 1 ~ week 26,
"A~Z" showed on 4th position --> week 27 ~ week 52.