



General Description

AP1250GM/H is a linear regulator designed as a cost-effective solution for active termination of DDR SDRAM. The converting voltage range is from 1.6V to 6V into a desired output voltage, which is adjusted by two external resistors. The current sourcing and sinking capability of the regulator is up to 1.5A/3A while the output voltage within 2%/3%.

This device provides on-chip thermal shutdown and current limit functions for circuit tolerance of the output fault conditions. SO-8 and TO-252-5L packages are available for all commercial and industrial surface mount applications.

Features

- ▼ Ideal for DDR-I and DDR-II applications
- ▼ Capable of sourcing and sinking current 1.5A/3A
- ▼ Current limiting protection
- ▼ Thermal protection
- ▼ Current-shoot-through protection
- ▼ High accuracy output voltage at full load
- ▼ Minimum external components
- ▼ Adjustable V_{OUT} by external resistors
- ▼ Shutdown for standby or suspend mode operation with high-impedance output

Block Diagram

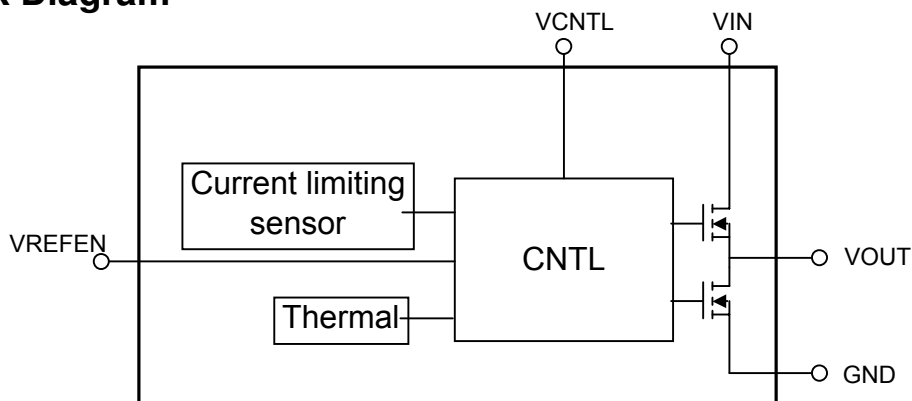



AP1250GM / AP1250GH

Applications

- ▼ Mother Board DDR-SDRAM Termination
- ▼ Mother Board DDR-II Termination
- ▼ Game / Play Station
- ▼ Set Top Box
- ▼ PCI / AGP Graphics
- ▼ IPC
- ▼ SCSI-III Bus Termination

Pin Configuration

•Part No. AP1250GM (SO-8 package)

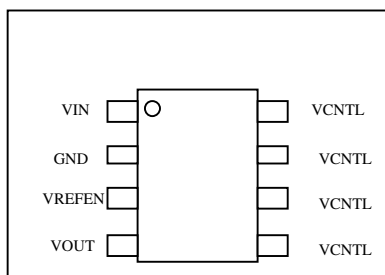

•Part No. AP1250GH (TO-252-5L package)

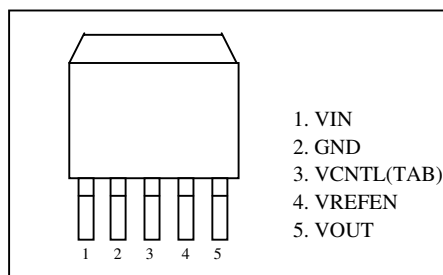

Pin Description

Pin Name	Function
VIN	Power Input
GND	Ground
VCNTL	Gate Drive Voltage
VREFEN	Reference Voltage Input and Chip Enable
VOUT	Output Voltage

Ordering Information

AP1250GX

Package

M : SO-8
H : TO-252-5L



Absolute Maximum Ratings

Power Input Voltage	6V
Power Dissipation	internal limited
HBM ESD Rating	3KV
Storage Temperature Range	-55 °C to 150 °C
Lead Temperature(Soldering 5 sec)	260 °C
SO-8 Thermal Resistance ³ (R _{thjc})	20°C/W
SO-8 Thermal Resistance(R _{thja})	80°C/W
TO-252-5L Thermal Resistance(R _{thjc})	6°C/W
TO-252-5L Thermal Resistance(R _{thja})	40°C/W

Electrical Characteristics @ T_A = 25°C (unless otherwise specified)

V_{IN} = +2.5V, V_{CNTL} = +3.3V, V_{REFEN} = +1.25V, C_{OUT} = 10uF(Ceramic)

Symbol	Parameter	Test Conditions	Min.	Typ.	Max.	Units
V _{OS}	Output Offset Voltage ¹	I _{OUT} = 0A	-20	-5	20	mV
Δ V _{LOAD}	Load Regulation	I _L : 0 --> 1.5A	--	0.5	2	%
		I _L : 1.5 --> 3A	--	2	3	%
V _{IN}	Input Voltage Range(DDR I/II) ²	V _{CNTL} >= V _{IN}	1.6	2.5/1.8	--	V
V _{CNTL}	Gate Drive Voltage Range ²	V _{CNTL} >= V _{IN}	--	3.3	6	V
I _{SHDN}	Current in Shutdown	V _{REFEN} < 0.2V, R _L = 180Ω	--	10	90	uA
<i>Short Circuit Protection</i>						
I _{LIMIT}	Current Limit	AP1250M	--	2	--	A
		AP1250H	--	3	--	A
I _q	Quiescent Current	I _{OUT} = 0A	--	1	3	mA
<i>Over Temperature Protection</i>						
T _{OS}	Thermal Shutdown Temperature	3.3V ≤ V _{CNTL} ≤ 5V	--	140	--	°C
<i>Shutdown Function</i>						
	Shutdown Threshold Trigger	Output = High	0.8	--	--	V
	Shutdown Threshold Trigger	Output = Low	--	--	0.2	V

Notes:

1. V_{OS} is the voltage measurement V_{OUT} subtracted from V_{REFEN}.
2. Keep V_{CNTL} >= V_{IN} at power on/off sequences.
3. Surface mounted on 1 in² copper pad of FR4 board



Application Circuit

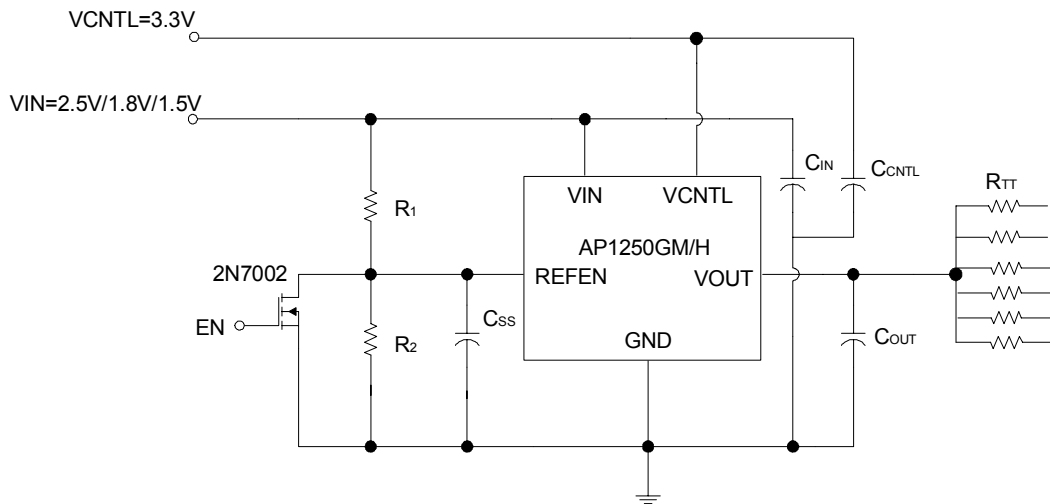

$R_1=R_2=100\text{K}\Omega$, $R_{TT}=50\Omega/33\Omega/25\Omega$

C_{OUT} , min=10uF(Ceramic) +1000uF Under the worst case test condition

$C_{SS}=1\mu\text{F}$, $C_{IN}=470\mu\text{F}$ (Low ESR), $C_{CNTL}=47\mu\text{F}$



AP1250GM / AP1250GH

Typical Performance Characteristics

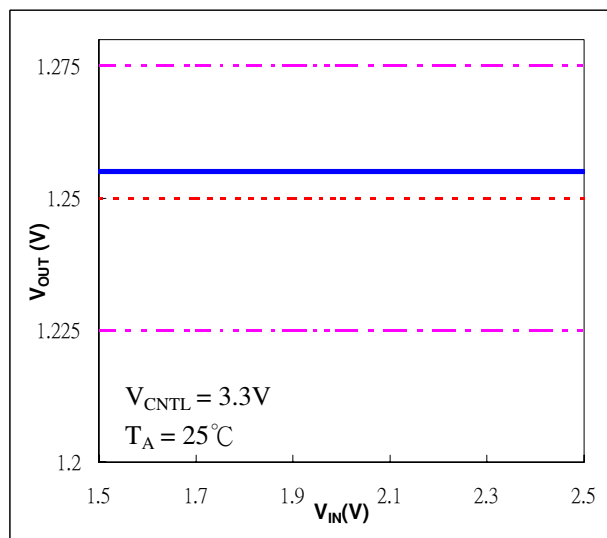

Fig 1. Line Regulation(V_{IN} vs. V_{OUT})

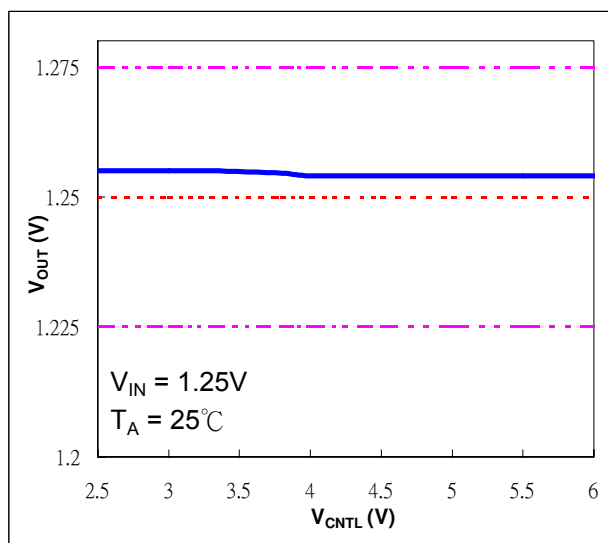

Fig 2. Line Regulation(V_{CNTL} vs. V_{OUT})

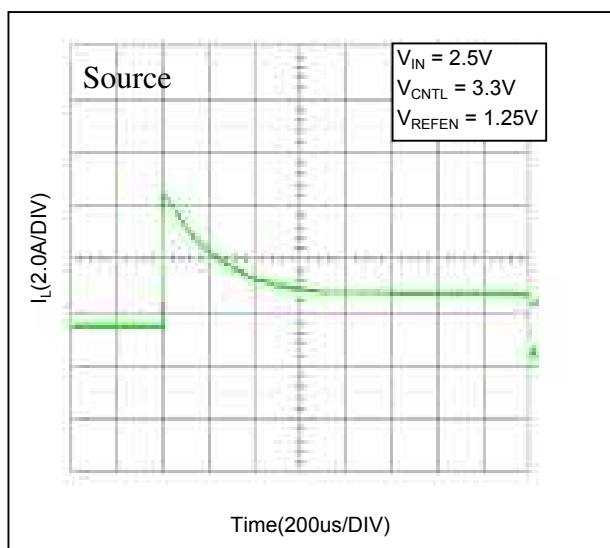

Fig 3. Output Short-Circuit Protection

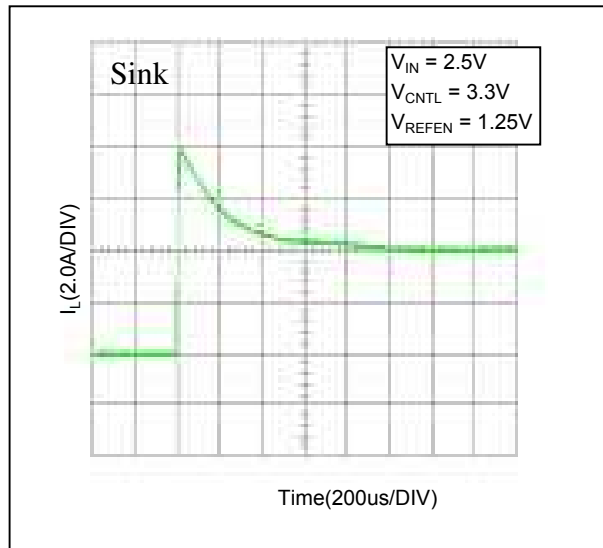

Fig 4. Output Short-Circuit Protection



Typical Performance Characteristics

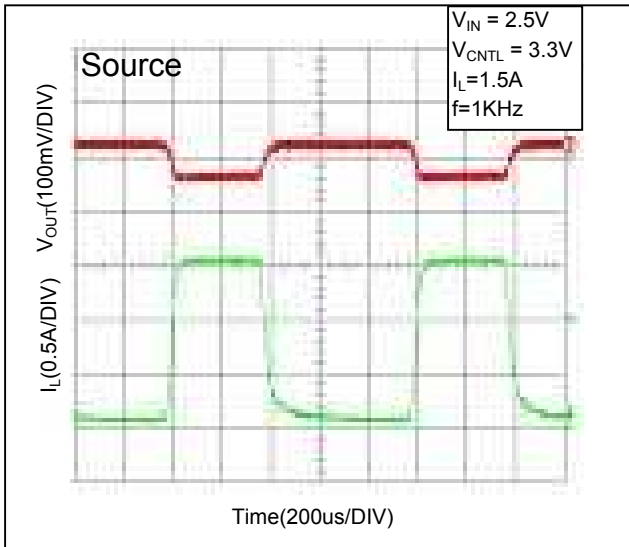

Fig 5. Transient Response

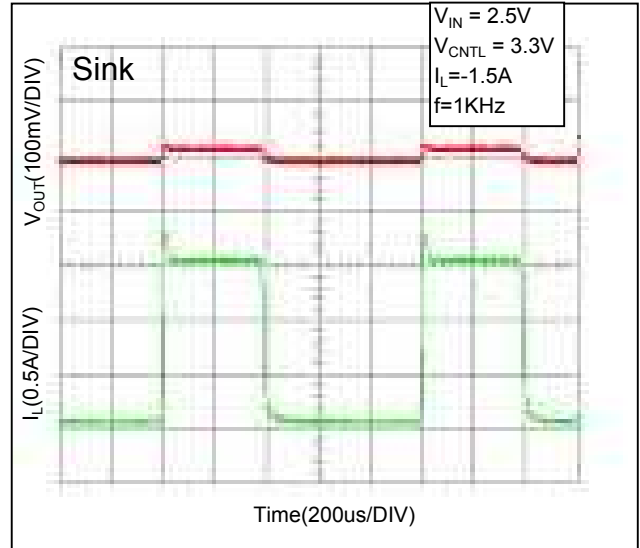

Fig 6. Transient Response

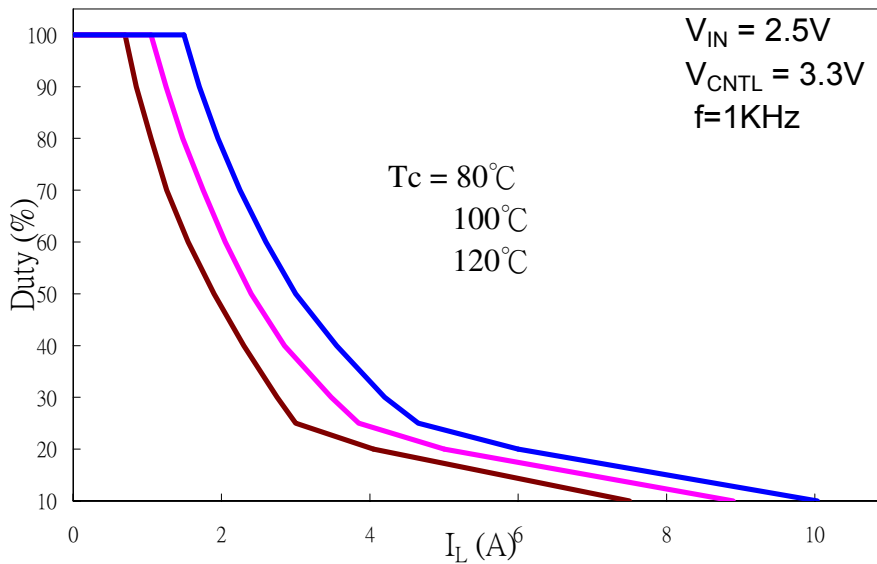

Fig 7. Safe Operating Area