

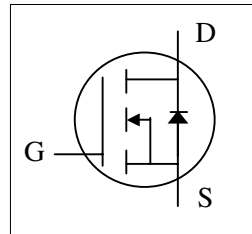

- ▼ **100% Avalanche Test**
- ▼ **Fast Switching Characteristic**
- ▼ **Simple Drive Requirement**



BV_{DSS}	600V
$R_{DS(ON)}$	0.6 Ω
I_D	10A

Description

AP3990 series are specially designed as main switching devices for universal 90~265VAC off-line AC/DC converter applications. The TO-3P type provide high blocking voltage to overcome voltage surge and sag in the toughest power system with the best combination of fast switching, ruggedized design and cost-effectiveness.

The TO-3P package is widely preferred for commercial-industrial applications. The device is suited for switch mode power supplies, DC-AC converters and high current high speed switching circuits.

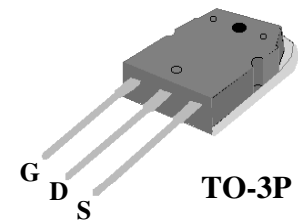

Absolute Maximum Ratings

Symbol	Parameter	Rating	Units
V_{DS}	Drain-Source Voltage	600	V
V_{GS}	Gate-Source Voltage	± 30	V
$I_D@T_C=25^\circ C$	Continuous Drain Current, $V_{GS} @ 10V$	10	A
$I_D@T_C=100^\circ C$	Continuous Drain Current, $V_{GS} @ 10V$	6.5	A
I_{DM}	Pulsed Drain Current ¹	40	A
$P_D@T_C=25^\circ C$	Total Power Dissipation	174	W
E_{AS}	Single Pulse Avalanche Energy ²	50	mJ
I_{AR}	Avalanche Current	10	A
T_{STG}	Storage Temperature Range	-55 to 150	$^\circ C$
T_J	Operating Junction Temperature Range	-55 to 150	$^\circ C$

Thermal Data

Symbol	Parameter	Value	Unit
Rthj-c	Maximum Thermal Resistance, Junction-case	0.72	$^\circ C/W$
Rthj-a	Maximum Thermal Resistance, Junction-ambient	40	$^\circ C/W$



Electrical Characteristics@T_j=25°C(unless otherwise specified)

Symbol	Parameter	Test Conditions	Min.	Typ.	Max.	Units
BV _{DSS}	Drain-Source Breakdown Voltage	V _{GS} =0V, I _D =1.0mA	600	-	-	V
R _{DS(ON)}	Static Drain-Source On-Resistance	V _{GS} =10V, I _D =5.0A	-	-	0.6	Ω
V _{GS(th)}	Gate Threshold Voltage	V _{DS} =V _{GS} , I _D =250uA	3	-	5	V
g _{fs}	Forward Transconductance	V _{DS} =10V, I _D =5A	-	5	-	S
I _{DSS}	Drain-Source Leakage Current	V _{DS} =600V, V _{GS} =0V	-	-	20	uA
	Drain-Source Leakage Current (T _j =125°C)	V _{DS} =600V, V _{GS} =0V	-	-	200	uA
I _{GSS}	Gate-Source Leakage	V _{GS} =±30V	-	-	±100	nA
Q _g	Total Gate Charge ³	I _D =10A	-	34	57	nC
Q _{gs}	Gate-Source Charge	V _{DS} =480V	-	11	-	nC
Q _{gd}	Gate-Drain ("Miller") Charge	V _{GS} =10V	-	11	-	nC
t _{d(on)}	Turn-on Delay Time ³	V _{DD} =300V	-	19	-	ns
t _r	Rise Time	I _D =10A	-	28	-	ns
t _{d(off)}	Turn-off Delay Time	R _G =10Ω, V _{GS} =10V	-	43	-	ns
t _f	Fall Time	R _D =30Ω	-	22	-	ns
C _{iss}	Input Capacitance	V _{GS} =0V	-	2030	3250	pF
C _{oss}	Output Capacitance	V _{DS} =25V	-	225	-	pF
C _{rss}	Reverse Transfer Capacitance	f=1.0MHz	-	9	-	pF

Source-Drain Diode

Symbol	Parameter	Test Conditions	Min.	Typ.	Max.	Units
V _{SD}	Forward On Voltage ³	I _S =10A, V _{GS} =0V	-	-	1.5	V
t _{rr}	Reverse Recovery Time ³	I _S =10A, V _{GS} =0V,	-	600	-	ns
Q _{rr}	Reverse Recovery Charge	dI/dt=100A/μs	-	12	-	uC

Notes:

- 1.Pulse width limited by Max. junction temperature.
- 2.Starting T_j=25°C , V_{DD}=50V , L=1.0mH , R_G=25Ω , I_{AS}=10A.
- 3.Pulse test

THIS PRODUCT IS SENSITIVE TO ELECTROSTATIC DISCHARGE, PLEASE HANDLE WITH CAUTION.

USE OF THIS PRODUCT AS A CRITICAL COMPONENT IN LIFE SUPPORT OR OTHER SIMILAR SYSTEMS IS NOT AUTHORIZED.

APEC DOES NOT ASSUME ANY LIABILITY ARISING OUT OF THE APPLICATION OR USE OF ANY PRODUCT OR CIRCUIT DESCRIBED HEREIN; NEITHER DOES IT CONVEY ANY LICENSE UNDER ITS PATENT RIGHTS, NOR THE RIGHTS OF OTHERS.

APEC RESERVES THE RIGHT TO MAKE CHANGES WITHOUT FURTHER NOTICE TO ANY PRODUCTS HEREIN TO IMPROVE RELIABILITY, FUNCTION OR DESIGN.

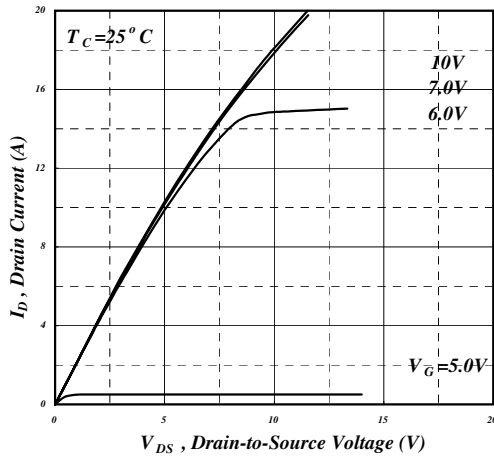

Fig 1. Typical Output Characteristics

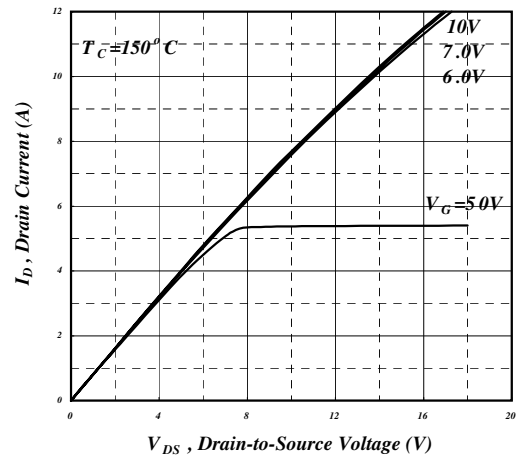

Fig 2. Typical Output Characteristics

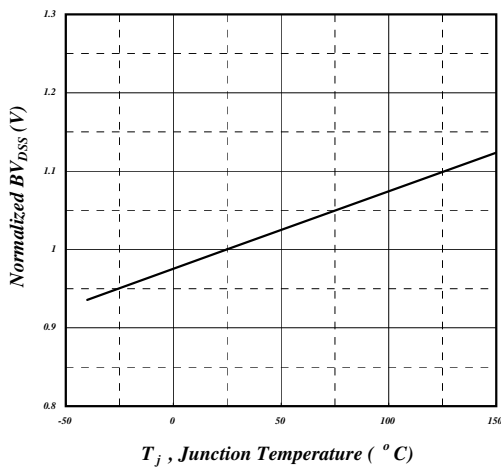

Fig 3. Normalized BV_{DSS} v.s. Junction Temperature

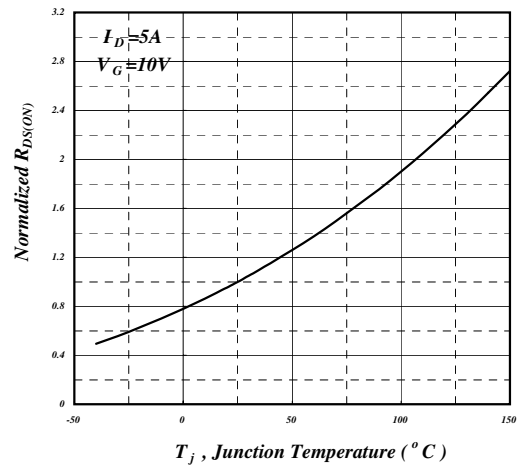

Fig 4. Normalized On-Resistance v.s. Junction Temperature

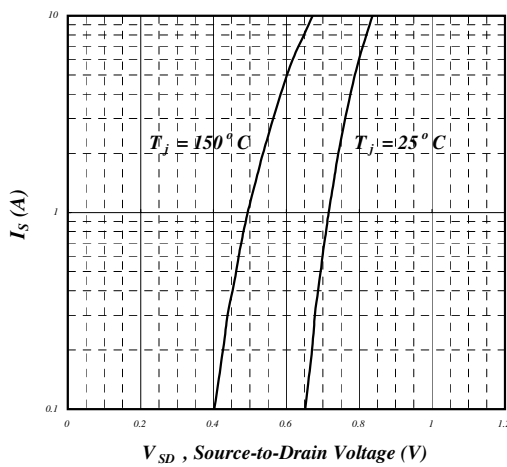

Fig 5. Forward Characteristic of Reverse Diode

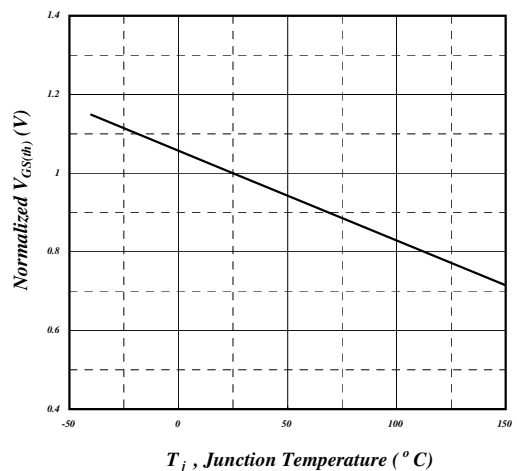

Fig 6. Gate Threshold Voltage v.s. Junction Temperature

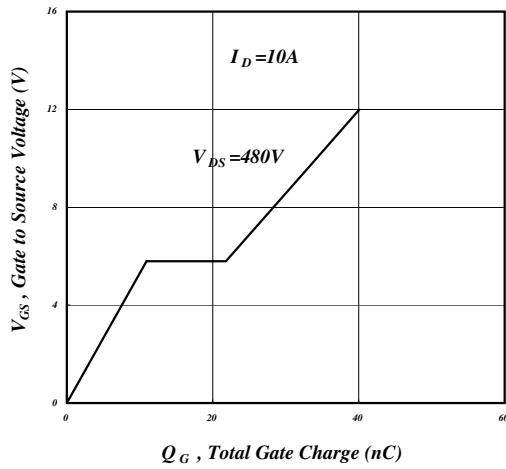

Fig 7. Gate Charge Characteristics

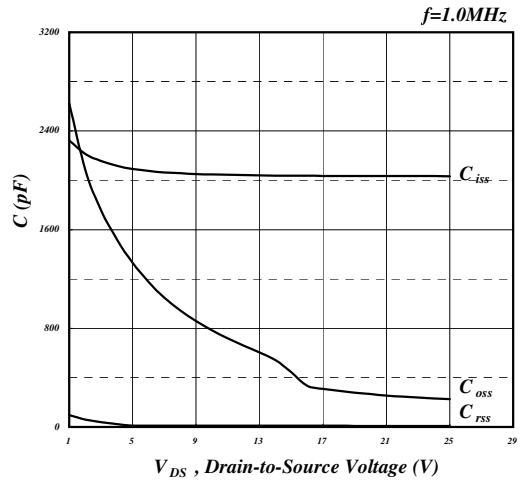

Fig 8. Typical Capacitance Characteristics

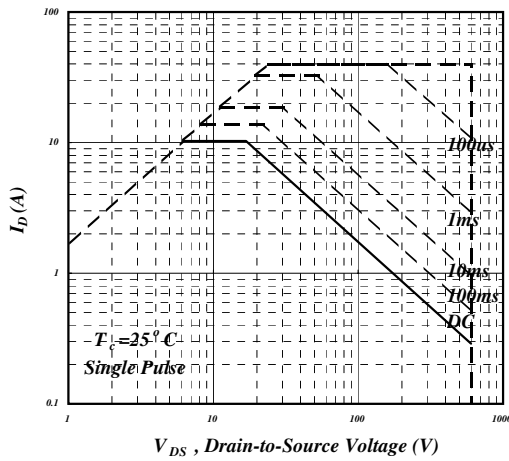

Fig 9. Maximum Safe Operating Area

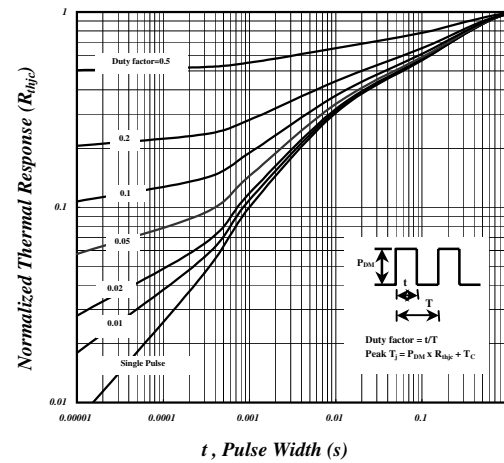

Fig 10. Effective Transient Thermal Impedance

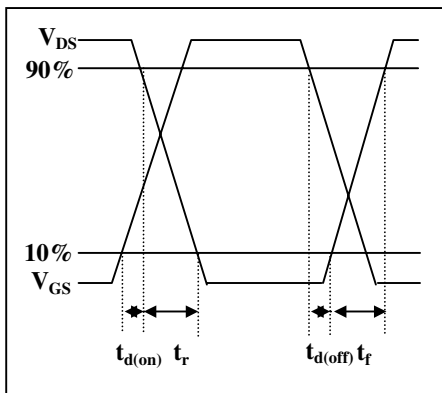

Fig 11. Switching Time Waveform

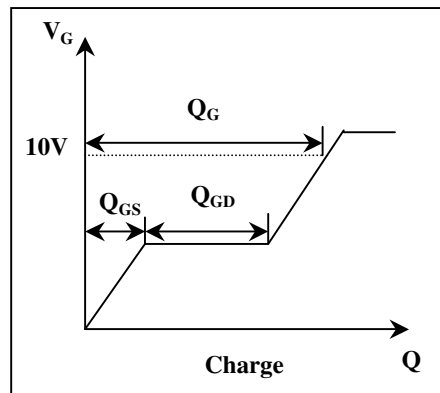
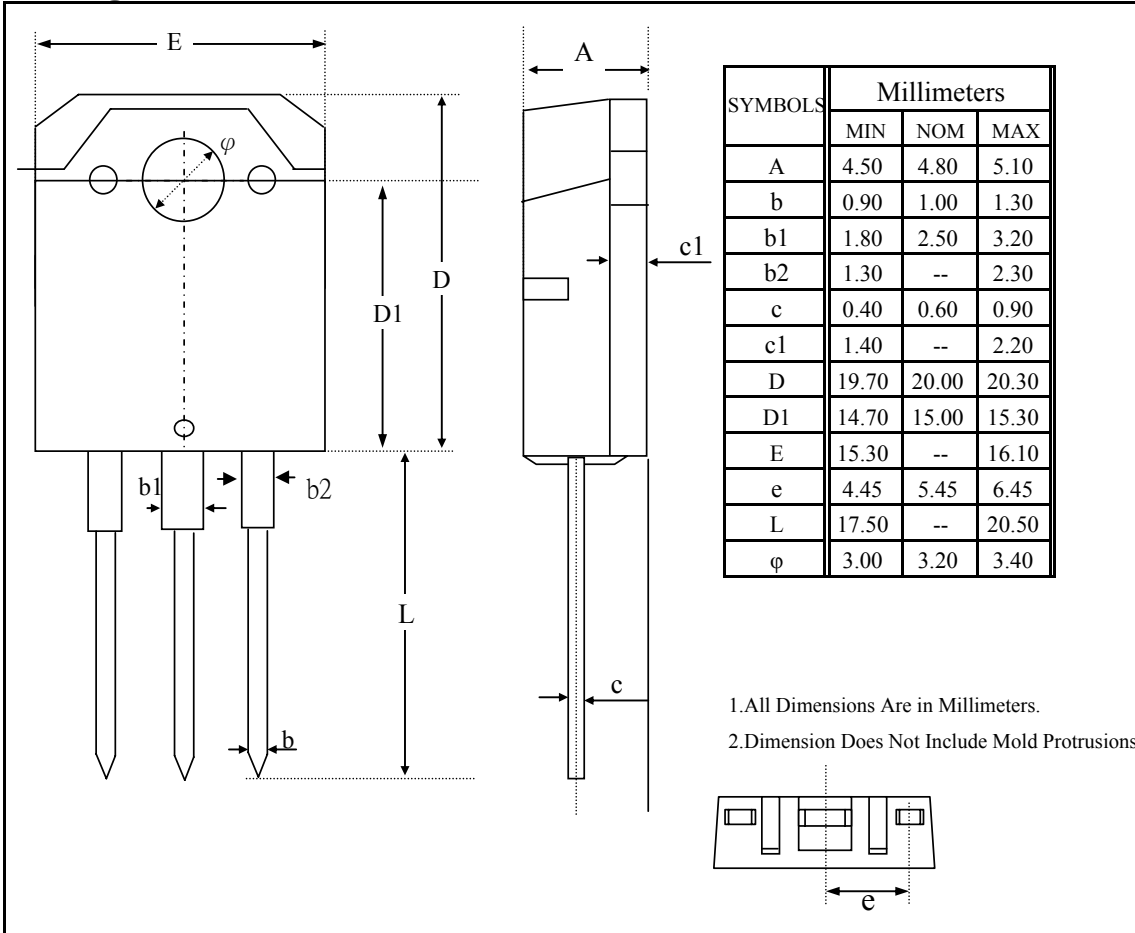

Fig 12. Gate Charge Waveform



Package Outline : TO-3P



Part Marking Information & Packing : TO-3P

