

OX/OY Series

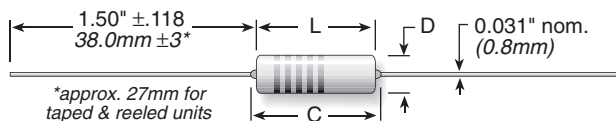

Ceramic Composition 10% Tolerance



*approx. 27mm for taped & reeled units

Series	Watts max.*	Resistance		Dimensions (in. / mm)		Diameter D ±.039 (±1.0)	Joules max.**	Max Working volts	Qty. per reel
		min.	max.	Length L ±.039 (±1.0)	Length C max.				
OX	1	3.3	100K	0.65 / 16.5	0.748 / 19.0	0.217 / 5.5	50	300	1000
OY	2	3.3	1M	0.748 / 19.0	0.886 / 22.5	0.276 / 7.0	80	400	500

* at 70°C. **For a single impulse.

The OX/OY Series of fixed ceramic resistors are ideal for circuitry associated with surges, high peak power or high energy. They offer enhanced performance in high voltage power supplies, R-C snubber circuits, and inrush limiters. The OX/OY resistors can often replace carbon composition resistors which can be difficult to source.

RESISTANCE TO PULSE

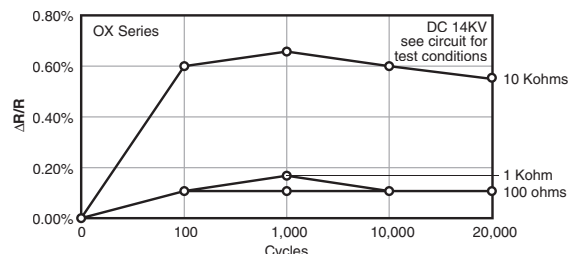
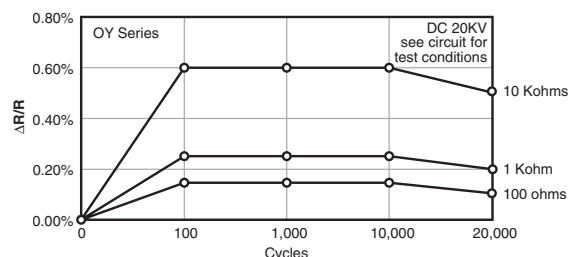

1 sec. on / 1 sec. off

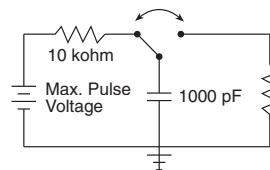

14KV and 20KV values used in circuit as shown; full voltage not applied directly to resistor.

FEATURES

- Replaces 1 and 2 watt carbon composition resistors
- Meets high energy density demands
- High peak power
- 10% Tolerance

SPECIFICATIONS

- Material**
Terminals: Pb-free solder-coated axial
Coating: Silicone ceramic
Derating: Linear from 100% @ +70°C to 0% @ +200°C
Operating Temp. Range: -40°C to +220°C
Electrical
Tolerance: ±10% standard
Power Rating: Based on 70°C free air rating.
Temperature Coefficient: -1300 ±300ppm/°C.

PERFORMANCE CHARACTERISTICS

Test	OX	OY
Max Working Voltage	300V	400V
Dielectric Strength	500V	700V
Max Overload Voltage	600V	800V
Max Pulse Voltage ¹	14KV	20KV
Pulse Tolerance, 100 pulses	1240V @ 52µF, 40J/ 35 sec.	1640V @ 52µF, 70J/35 sec.

Test	Condition	Maximum ΔR
Life Test	MIL-STD-202, Method 108	±5%
Short Time Overload	2x rated V, 5 sec ON @ 70°C	±(2% + 0.05ohm)
Resistance to Pulse ¹ 20,000 cycles	see circuit for test conditions	±5%
Thermal Shock	MIL-STD-202, Method 107	±(2% ± 0.05 ohm)
Moisture Resistance	1000 hrs @ 40°C, 90 - 95% RH	±5%

¹See figures, left

TAPE DIMENSIONS

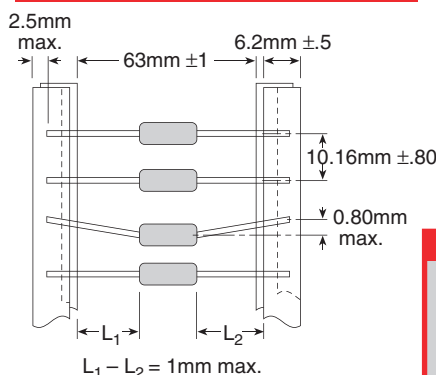

L₁ - L₂ = 1mm max.

REEL DIMENSIONS

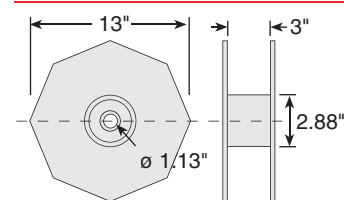

ORDERING INFORMATION

RoHS Compliant | Tape & reel optional

OX 8 2 G K E -TR

Size	Ohm Value	Tolerance
OX = 1W	Example: 33G = 3.3 Ohms	K = 10% Standard
OY = 2W	330 = 33 Ohms	
	331 = 330 Ohms	

STANDARD PART NUMBERS FOR OX/OY SERIES

Ohmic value	Part No. Prefix Suffix	Wattage		Ohmic value	Part No. Prefix Suffix	Wattage		Ohmic value	Part No. Prefix Suffix	Wattage		Ohmic value	Part No. Prefix Suffix	Wattage	
		1	2			1	2			1	2			1	2
3.3	—33GKE	✓	✓	27	—270KE	✓	✓	220	—221KE	✓	✓	1800	—182KE	✓	✓
3.9	—39GKE	✓	✓	33	—330KE	✓	✓	270	—271KE	✓	✓	2200	—222KE	✓	✓
4.7	—47GKE	✓	✓	39	—390KE	✓	✓	330	—331KE	✓	✓	2700	—272KE	✓	✓
5.6	—56GKE	✓	✓	47	—470KE	✓	✓	390	—391KE	✓	✓	3300	—332KE	✓	✓
6.8	—68GKE	✓	✓	56	—560KE	✓	✓	470	—471KE	✓	✓	3900	—392KE	✓	✓
8.2	—82GKE	✓	✓	68	—680KE	✓	✓	560	—561KE	✓	✓	4700	—472KE	✓	✓
10	—100KE	✓	✓	82	—820KE	✓	✓	680	—681KE	✓	✓	5600	—562KE	✓	✓
12	—120KE	✓	✓	100	—101KE	✓	✓	820	—821KE	✓	✓	6800	—682KE	✓	✓
15	—150KE	✓	✓	120	—121KE	✓	✓	1000	—102KE	✓	✓	8200	—822KE	✓	✓
18	—180KE	✓	✓	150	—151KE	✓	✓	1200	—122KE	✓	✓	10000	—103KE	✓	✓
22	—220KE	✓	✓	180	—181KE	✓	✓	1500	—152KE	✓	✓	12000	—123KE	✓	✓
												15000	—153KE	✓	✓
												18000	—183KE	✓	✓
												22000	—223KE	✓	✓
												27000	—273KE	✓	✓
												33000	—333KE	✓	✓
												39000	—393KE	✓	✓
												47000	—473KE	✓	✓
												56000	—563KE	✓	✓
												68000	—683KE	✓	✓
												82000	—823KE	✓	✓
												100000	—104KE	✓	✓
												120000	—124KE	✓	✓
												150000	—154KE	✓	✓
												180000	—184KE	✓	✓
												220000	—224KE	✓	✓
												270000	—274KE	✓	✓
												330000	—334KE	✓	✓
												390000	—394KE	✓	✓
												470000	—474KE	✓	✓
												560000	—564KE	✓	✓
												680000	—684KE	✓	✓
												820000	—824KE	✓	✓
												1 MEG	—105KE	✓	✓