

2010 SMD

0.6 Watt Wirewound Surface Mount Power

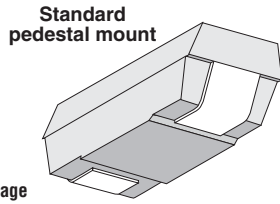

2010 Package

Series	Wattage	Ohms	Dimensions (in. / mm)			Voltage
			Length	Height	Width	
RW0S6BB	0.6	0.01-1K	0.202 / 5.14	0.135 / 3.42	0.1 / 2.54	50

PERFORMANCE DATA

Temp. cycle	(-55°C to 125°C, 1000 cycles)	±0.5%±.05Ω
Load Life	(1000 hours at 25°C)	±3.0%±.05Ω
Immersion	(260°C for 10 sec.)	±0.1%±.05Ω
Leaching	(260°C Solder immersion, 60 sec.)	No visible leaching
Thermal Shock	(Units at -55°C, then rated power applied)	No mechanical damage
Flammability	UL Material rating	UL94V0

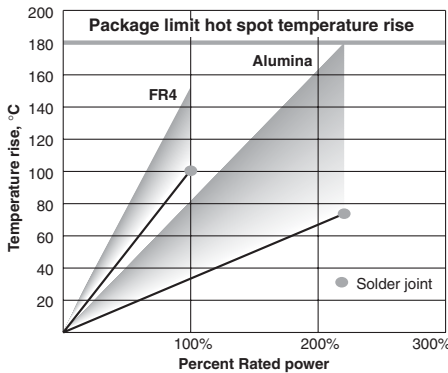

The temperature rise graph data was obtained by a selection of test substrate size and trace width for each resistor size to limit operating temperatures to safe values.

The operating temperature safe rises are either 100°C substrate temperature rise or 180°C package hot spot temperature rise at 25°C ambient.

FR4: 0.062 in. thick; 0.062 in. traces

Alumina: 0.040 in. thick; 0.010 in. traces

ORDERING INFORMATION

Component type: R = resistor
 Type of Base: S = standard
 Package: B = 12mm
 Package Modifier: A, B sequential
 Tolerance: F = 1%
 T = Tape and Reel (optional)
 E = RoHS compliant

RW0S6BB1K00FET

Component Modifier: W = wirewound
 Wattage: OS6 = 0.6W
 Resistance Value: R = Decimal, K = 1,000, M = 1,000,000
 Examples: R249 = 0.249 ohms, 24R9 = 24.9 ohms, 2K49 = 2,490 ohms

STANDARD PART NUMBERS FOR 2010 SMD

Ohms	Part Number	Ohms	Part Number
0.010	RW0S6BBR010FE	1.00	RW0S6BB1R00FE
0.015	RW0S6BBR015FE	2.00	RW0S6BB2R00FE
0.020	RW0S6BBR020FE	5.00	RW0S6BB5R00FE
0.030	RW0S6BBR030FE	7.50	RW0S6BB7R50FE
0.050	RW0S6BBR050FE	10.00	RW0S6BB10R0FE
0.075	RW0S6BBR075FE	15.00	RW0S6BB15R0FE
0.100	RW0S6BBR100FE	24.00	RW0S6BB24R0FE
0.240	RW0S6BBR240FE	36.00	RW0S6BB36R0FE
0.470	RW0S6BBR470FE	47.00	RW0S6BB47R0FE
0.750	RW0S6BBR750FE	100.00	RW0S6BB100RFE

Check product availability at www.ohmite.com

FEATURES

- 1% Tolerance standard
- Smallest wirewound on the market
- Available in low ohmic values

TCR

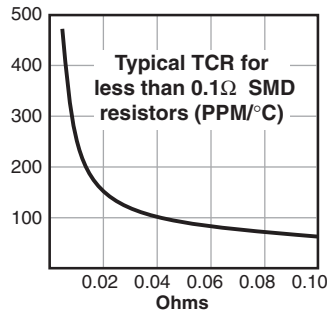

SPECIFICATIONS

- 25°C ambient
- Power: 0.6 watts
- Voltage (max.): 50V
- Tolerance: 1%
- Resistance range: 0.010Ω-1KΩ
- Temperature Coefficient: 0.1Ω-1Ω: ±90, 1Ω-10Ω: ±50, 10Ω+: ±20
- Dielectric Withstanding Voltage: 1000V
- Tape Size: 12mm, 13" reel, 2500 pcs. per reel.

DERATING

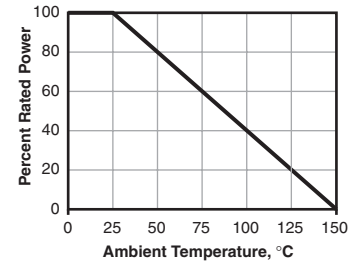

DIMENSIONS

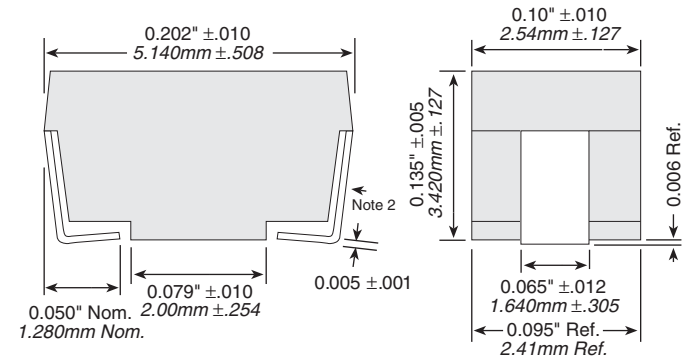

LAND PATTERN

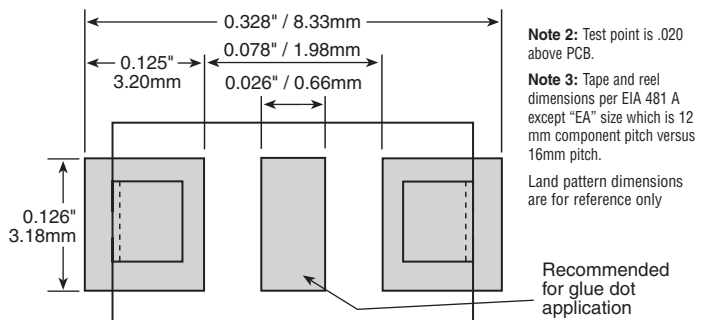

TAPE AND REEL

