

Ohmite's TCH35 TO220 package resistor provides 35W of steady state power when properly used in today's well defined heat sink applications.

These very low induction resistors are built under proprietary processes that deliver more power handling capability than other TO220 package resistors of similar size.

Standard terminal forms are provided for manual or automatic insertion.

A single screw mounting tab connects to the heat sink and should be accompanied by the use of a thermal compound. The TCH35 Series offers a low thermal resistance to the heat sink of $4.28^{\circ}\text{C}/\text{W}$.

FEATURES

- 35W Power Rating @ 25°C
- Very Low Inductance Design
- Single Screw Mounting
- Low Thermal Resistance to Heat Sink @ $R_{\text{TH}} < 4.28^{\circ}\text{C}/\text{W}</math>$
- Resistance Element is Electrically Insulated from Metal Heat Sink Mounting Tab

APPLICATIONS

- Switching Power Supplies
- Snubbers
- High Frequency
- Voltage Regulation
- Low Energy Pulse Loading

SPECIFICATIONS

Electrical

Resistance Range: 0.1Ω to 10KΩ (higher values on request subject to derating)

Resistance Tolerance:

- ± 5% standard
- ± 1% available on request

Temperature Coefficient:

Referenced to 25°C,
 ΔR taken at +105°C
 10Ω and above: ±50 ppm/°C
 For under 10Ω:

- 0R6 - 9R9 100PPM
- 0R4 - 0R59 150PPM
- 0R2 - 0R39 250PPM
- 0R1 - 0R19 500PPM
- 0R05 - 0R09 ... 1000PPM

Max. Operating Voltage: 350V

Dielectric Strength: 1800 VAC

Insulation Resistance: 10GΩ min.

Momentary Overload: 2x rated power for 5 seconds as long as the applied voltage ≤ 1.5 times the continuous operating voltage, where $\Delta R \pm (0.3\% + 0.01\Omega)$ max

Terminal Material: Copper

Terminal Plating: Lead Free Solder (97% Tin, 3% Silver)

Maximum Torque: 0.9 Nm

Power Rating: 35 Watts @ 25°C case temperature; see derating curve, below

Working Temperature Range: -55°C to +175°C

Solder Process: The TCH35 cannot exceed 260°C for more than 10 seconds during soldering process.



TCH Series

35 Watt TO220 Package
Thick Film Power

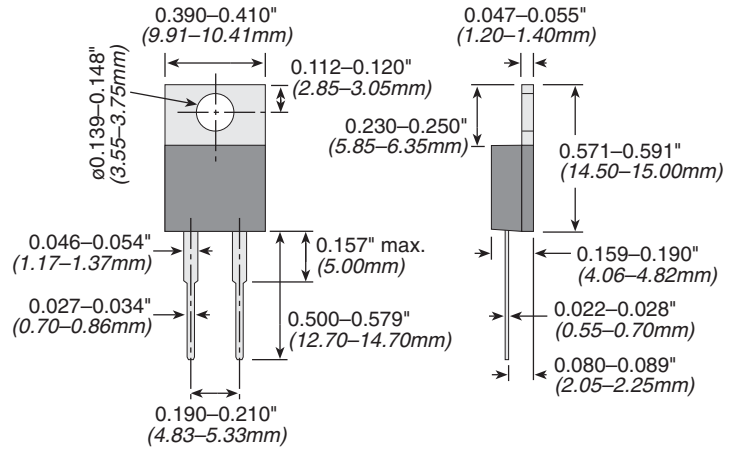

TEST DATA

Load Life	MIL-R-39009, 2000 Hours @ Rated Pwr	$\Delta R = \pm (1.0\% + 0.01) \Omega$
Thermal Shock	MIL-R-STD-202, Method 107, Cond. F	$\Delta R = \pm (0.3\% + 0.01) \Omega$ max
High Freq Vibration	MIL-R-STD-202, Method 204, Cond. D	$\Delta R = \pm (0.2\% + 0.01) \Omega$ max
Terminal Strength	MIL-R-STD-202, Method 211, Cond. A (Pull Test) 2.4N	$\Delta R = \pm (0.2\% + 0.01) \Omega$ max
Moisture Resistance	MIL-R-STD-202, Method 106	$\Delta R = \pm (0.5\% + 0.01) \Omega$ max

ORDERING INFORMATION

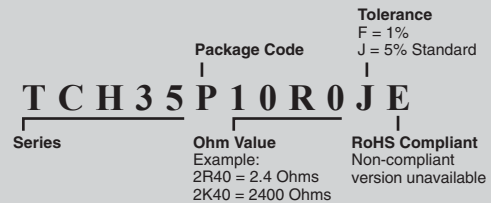

Check product availability at www.ohmite.com

DERATING CURVE

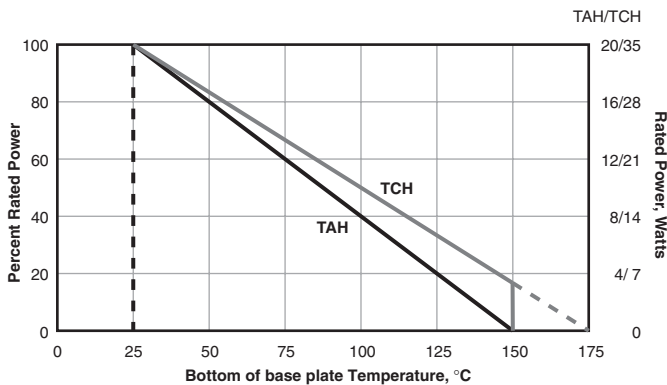

THIS PRODUCT IS DESIGNED FOR USE WITH PROPER HEATSINKING.

Maximum base plate temperature of the resistor must be monitored and kept within specified limits to establish the power rating. Best technique is to attach a thermocouple to the side of the base plate of the resistor. Temperature of plastic housing or heat sink cannot be used to establish rating of the resistor.

STANDARD PART NUMBERS

TCH35P100RJE	TCH35P220RJE	TCH35P330RJE	TCH35P510RJE	TCH35PR200JE
TCH35P10K0JE	TCH35P22R0JE	TCH35P390RJE	TCH35P51R0JE	TCH35PR220JE
TCH35P10R0JE	TCH35P240RJE	TCH35P39R0JE	TCH35P5K10JE	TCH35PR240JE
TCH35P150RJE	TCH35P24R0JE	TCH35P3K30JE	TCH35P5R10JE	TCH35PR330JE
TCH35P15R0JE	TCH35P2K00JE	TCH35P3K90JE	TCH35P5R60JE	TCH35PR390JE
TCH35P1K00JE	TCH35P2K20JE	TCH35P3R30JE	TCH35P750RJE	TCH35PR470JE
TCH35P1K50JE	TCH35P2K40JE	TCH35P3R90JE	TCH35P7R0JE	TCH35PR510JE
TCH35P1R00JE	TCH35P2R00JE	TCH35P470RJE	TCH35P7K50JE	TCH35PR560JE
TCH35P1R50JE	TCH35P2R20JE	TCH35P47R0JE	TCH35P7R50JE	TCH35PR750JE
TCH35P200RJE	TCH35P2R40JE	TCH35P4K70JE	TCH35PR100JE	TCH35PR050JE
TCH35P20R0JE	TCH35P330RJE	TCH35P4R70JE	TCH35PR150JE	