

# D Series



## Heatsink For TO-252, TO-263 and TO-268 devices



THERMAL MANAGEMENT

Ohmite D Series heatsinks provide an innovative solution for SMT compatible semiconductors and resistors. The unique design (Patent Pending) combines tin plated, solderable rods with an aluminum extruded heat sink body. These rods (or “rollers”) are mated mechanically to the heatsink by forging to reduce the thermal resistance between the heatsink body and the solderable feet.

Specifically designed for use with the increasingly popular TO-252, TO-263 and TO-268 packages, the D Series affords the user superior thermal performance over the more common stamped aluminum heatsinks. By eliminating the staking joint typically used in stamped heatsinks, the resulting air gap and thermal “bottle-neck” is also eliminated, while surface area for cooling is maximized with the extruded fins of the D Series body.

### FEATURES

- Increased surface areas by 3 times therefore thermal performance up to 300% over the aluminum stamped heat sinks on markets
- Light weight aluminum construction allows faster pick and place assembly reducing the manufacturing cycle time
- Radius mounted “Rollers” are designed for maximizing heat transfer from the component and avoiding the thermal “bottle-neck” seen in stamped and staked heatsinks.
- Available in bulk packaging or tape & reel (250 units per reel)
- RoHS Compliant

### HEAT DISSIPATION

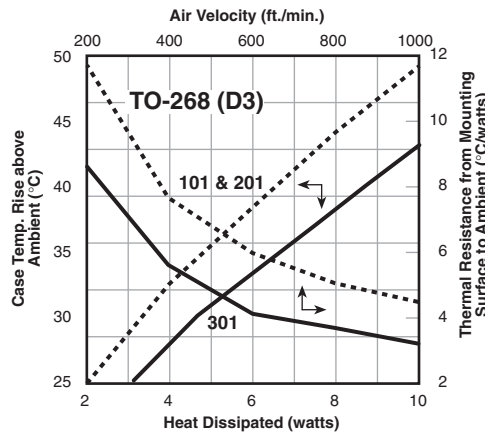
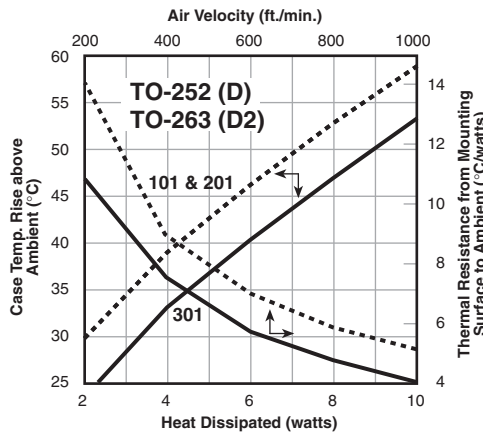

Final thermal performance is highly dependent on the thermal characteristics of the PCB. It is possible to see a 50% drop in temp rise in natural convection with a thermally improved PCB.

### DIMENSIONS

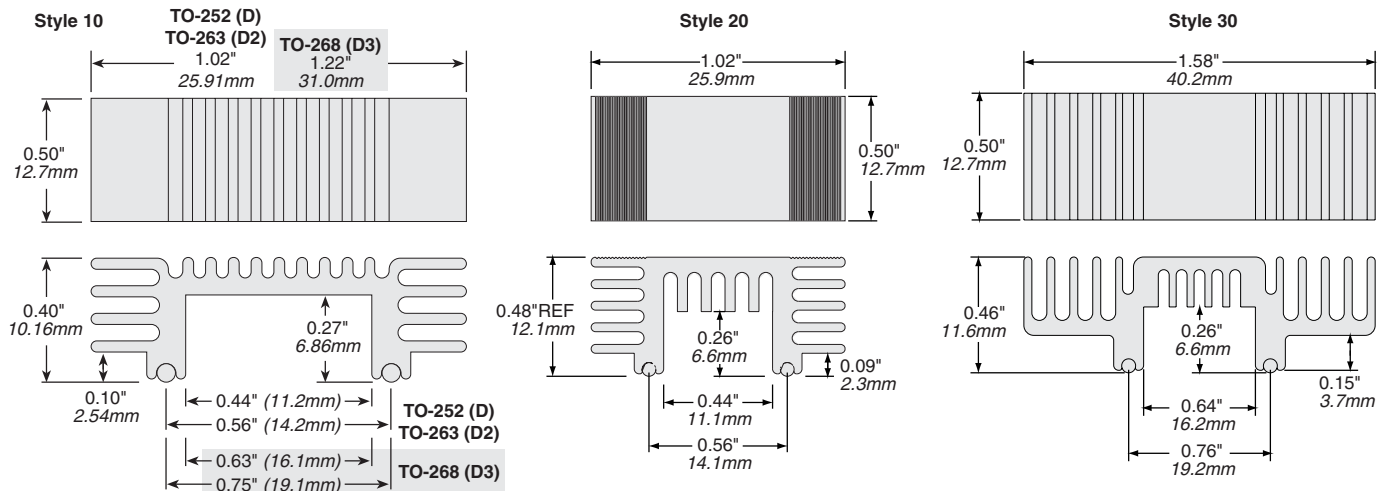

# D Series

## Heatsink For TO-252, TO-263 and TO-268 devices

### LAND PATTERNS

Land Patterns for D, D2 and D3

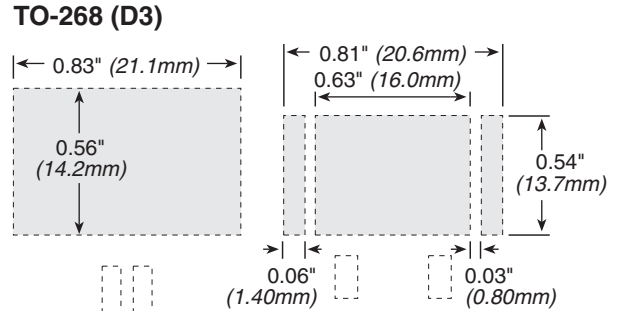
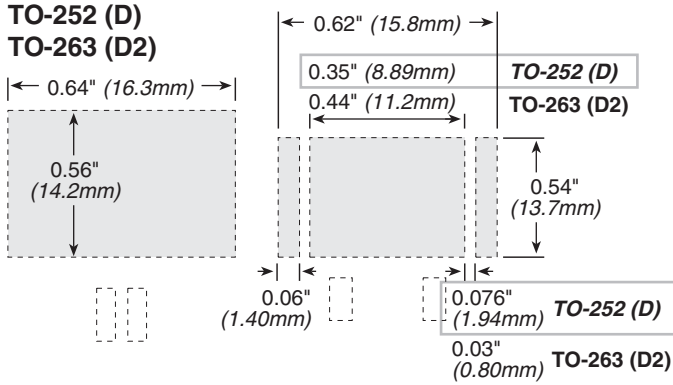

### TAPE AND REEL

Reel diameter: 13.00" (330.00mm)  
250 pcs. per

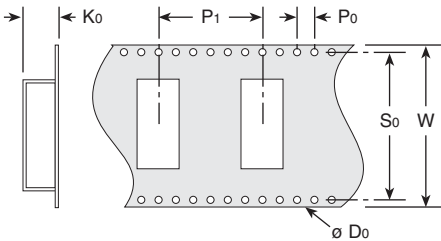

	Style 10	Style 20	Style 30
Do	1.55mm	1.5mm	1.5mm
Ko	10.5mm	12.20mm	11.50mm
Po	4mm	4.0mm	4.0mm
P1	24mm	24mm	24.0mm
So	40.4mm	40.4mm	52.4mm
Wo	44mm	44mm	56mm

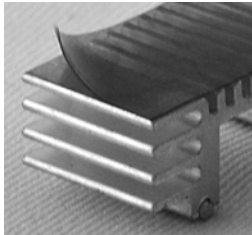

Removable Kapton tape on each part facilitates handling by automatic pick and place equipment. **Style 10 tape and reel only.**

### ORDERING INFORMATION

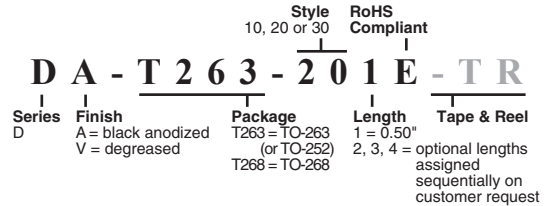

### Standard part numbers For D Series

Part Number	Description	Packaging	Weight
DV-T263-101E	for D2 pack, degreased	Bulk	3.8 g
DA-T263-101E	for D2 pack, black anodized	Bulk	3.8 g
DV-T263-101E-TR	for D2 pack, degreased	Reel	3.8 g
DA-T263-101E-TR	for D2 pack, black anodized	Reel	3.8 g
DV-T268-101E	for D3 pack, degreased	Bulk	4.1 g
DA-T268-101E	for D3 pack, black anodized	Bulk	4.1 g
DV-T268-101E-TR	for D3 pack, degreased	Reel	4.1 g
DA-T268-101E-TR	for D3 pack, black anodized	Reel	4.1 g
DV-T263-201E	for D or D2 pack, degreased	Bulk	
DA-T263-201E	for D or D2 pack, black anodized	Bulk	
DV-T263-201E-TR	for D or D2 pack, degreased	Reel	
DA-T263-201E-TR	for D or D2 pack, black anodized	Reel	
DV-T268-301E	for D3 pack, degreased	Bulk	
DA-T268-301E	for D3 pack, black anodized	Bulk	
DV-T268-301E-TR	for D3 pack, degreased	Reel	
DA-T268-301E-TR	for D3 pack, black anodized	Reel	