

General Description

The AAT3532 PowerManager is a member of AnalogicTech's Total Power Management IC™ (TPMIC™) product family. It is a fully integrated device for monitoring microprocessor activity, external reset, and power supply conditions. The device holds the microprocessor in a reset condition for a minimum of 250ms while V_{CC} is established to ensure correct system start-up. A manual reset can be initiated via a de-bounced input pin. As an additional level of protection, the AAT3532 includes a watchdog timer which requires a periodic strobe input from the microprocessor to ensure correct operation. The AAT3532 has a programmable watchdog timer and voltage tolerance level. The quiescent supply current is extremely low, typically 23 μ A.

The AAT3532 is available in a Pb-free, 8-pin SOP package and is specified over the -40°C to +85°C temperature range.

Features

- Adjustable 4.5V or 4.75V Voltage Monitor
- 250ms (min) Reset Pulse Width
- Low Quiescent Current: Typically 23 μ A
- Adjustable Watchdog Timer (150ms, 600ms, or 1200ms)
- De-bounced Manual Reset Input
- Operates Down to 20ns Strobe Input Pulse Width
- No External Components
- Temperature Range: -40° to +85°C
- Standard 8-Pin SOP Package
- Pin Compatible with MAX1232

Applications

- Automotive
- Computers
- Controllers
- Embedded Systems
- Intelligent Instrumentation
- Telecom Equipment

Typical Application

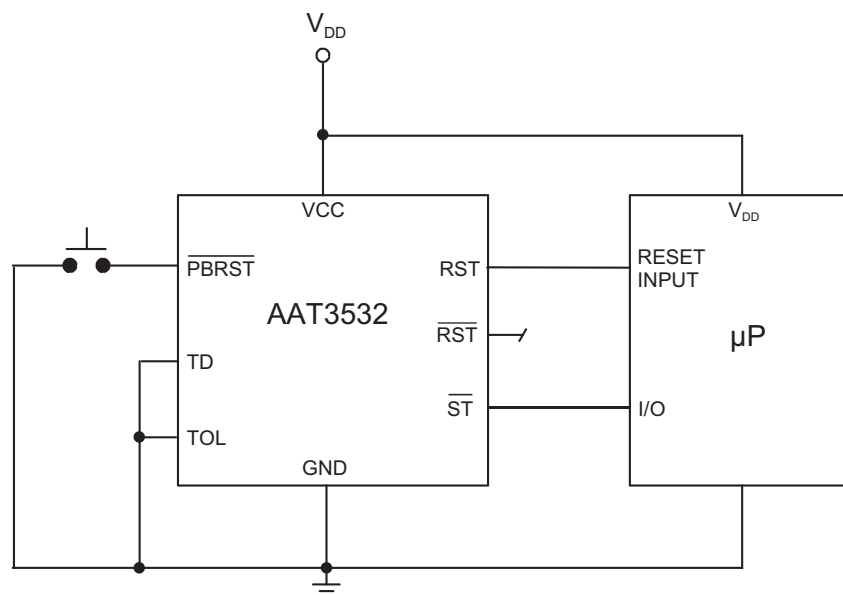

Pin Descriptions

Pin #	Symbol	Function
1	$\overline{\text{PBRST}}$	Push-button reset input. A de-bounced active low input for manual reset. Guaranteed to recognize inputs 20ms or greater.
2	TD	Watchdog time delay set input. See Table 1 for watchdog timeout selections.
3	TOL	Tolerance set. Input selects 5% or 10% threshold detection.
4	GND	IC ground connection.
5	RST	Reset output (active high). Activated when either: V_{CC} falls below the reset voltage threshold; $\overline{\text{PBRST}}$ is forced low; $\overline{\text{ST}}$ is not strobed within the minimum timeout period; or during power-up.
6	$\overline{\text{RST}}$	Reset output (active low, open drain). Inverse of RST.
7	$\overline{\text{ST}}$	Strobe input to watchdog timer. A pulse is required within the watchdog timeout period to prevent $\overline{\text{RST}}$ and RST entering active state.
8	VCC	5V supply.

Pin Programming Selections

TD Pin	Timeout		
	Min	Typ	Max
GND	62.5ms	150ms	250ms
Float	250ms	600ms	1000ms
V_{CC}	500ms	1200ms	2000ms

Table 1: TD Pin Programming for Watchdog Timeout Selections.

TOL Pin	Tolerance
V_{CC}	10%
GND	5%

Table 2: Reset Voltage Threshold Programming Selections.

Pin Configuration

SOP-8
(Top View)

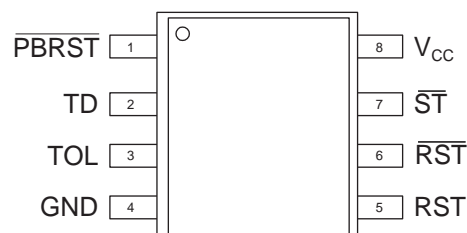

Absolute Maximum Ratings¹

$T_A = 25^\circ\text{C}$, unless otherwise noted.

Symbol	Description	Value	Units
V_{CC}	V_{CC} to GND	-0.5 to 6	V
$V_{I/O}$	Voltage on I/O Pins Relative to GND	-0.5 to ($V_{CC}+0.5$)	V
T_A	Operating Temperature Range	-40 to 85	$^\circ\text{C}$
T_S	Storage Temperature Range	-65 to 150	$^\circ\text{C}$
T_{LEAD}	Maximum Soldering Temperature (at leads, 10 sec.)	300	$^\circ\text{C}$
V_{ESD}	ESD Rating ² —HBM	2000	V

Thermal Characteristics³

Symbol	Description	Value	Units
Θ_{JA}	Maximum Thermal Resistance	100	$^\circ\text{C}/\text{W}$
P_D	Maximum Power Dissipation	1.25	W

1. Stresses above those listed in Absolute Maximum Ratings may cause permanent damage to the device. Functional operation at conditions other than the operating conditions specified is not implied. Only one Absolute Maximum Rating should be applied at any one time.

2. Human body model is a 100pF capacitor discharged through a 1.5k Ω resistor into each pin.

3. Mounted on an FR4 board.

DC Electrical Characteristics

$V_{IN} = 4.5V$ to $5.5V$, $T_A = -40^{\circ}C$ to $+85^{\circ}C$, unless otherwise noted. Typical values are $T_A = 25^{\circ}C$.

Symbol	Description	Conditions	Min	Typ	Max	Units	
V_{CC}	Supply Voltage		4.5	5.0	5.5	V	
I_Q	Quiescent Current ¹	$V_{CC} = 5.5V$	CMOS Levels		23	50	μA
			TTL Levels		160	500	
V_{CCTP}	Reset Threshold 5%	TOL = GND	4.50	4.62	4.74	V	
	Reset Threshold 10%	TOL = V_{CC}	4.25	4.37	4.49		
I_{IL}	Input Leakage \overline{ST} , TOL		-1.0		1.0	μA	
I_{OH}	Output Current RST ²	$V_{OH} = 2.4V$	-8.0			mA	
I_{OL}	Current RST ² , \overline{RST}	$V_{OL} = 0.4V$	10.0			mA	
V_{IH}	\overline{ST} and \overline{PBRST} Input High		2.0		$V_{CC} + 0.3$	V	
V_{IL}	\overline{ST} and \overline{PBRST} Input Low		-0.3		0.8	V	
I_{RST}	\overline{RST} Output Leakage	$V_{OH} = V_{CC}$			1.0	μA	

AC Electrical Characteristics

$V_{IN} = 4.5V$ to $5.5V$, $T_A = -40^{\circ}C$ to $+85^{\circ}C$, unless otherwise noted. Typical values are $T_A = 25^{\circ}C$.

Symbol	Description	Conditions	Min	Typ	Max	Units
C_{IN}	Input Capacitance \overline{ST} , TOL ³	$T_A = 25^{\circ}C$			5	pF
C_{OUT}	Output Capacitance RST, \overline{RST} ³	$T_A = 25^{\circ}C$			7	pF
t_{PB}	\overline{PBRST} ⁴	See Figure 2	20			ms
t_{PBD}	\overline{PBRST} Delay	See Figure 2	1	4	20	ms
t_{RST}	Reset Active Time		250	610	1000	ms
t_{ST}	\overline{ST} Pulse Width	See Figure 3	20			ns
t_{TD}	\overline{ST} Time-out Period	TD Pin = 0V	62.5	150	250	ms
		TD Pin = Open	250	600	1000	
		TD Pin = V_{CC}	500	1200	2000	
t_f	V_{CC} Fall Time ³	4.75V to 4.25V	10			μs
t_r	V_{CC} Rise Time ³	4.25V to 4.75V	0	5		μs
t_{RPD}	V_{CC} Detect to RST High and \overline{RST} Low	V_{CC} Falling			50	μs
t_{RPU}	V_{CC} Detect to RST Low and \overline{RST} Open	V_{CC} Rising	250	610	1000	ms

1. Measured with outputs open and \overline{ST} toggling at 100kHz, 50% duty cycle.

2. \overline{RST} is an open drain output.

3. Guaranteed by design and not subject to production testing.

4. \overline{PBRST} must remain low for greater than 20ms to guarantee a reset.

Functional Block Diagram

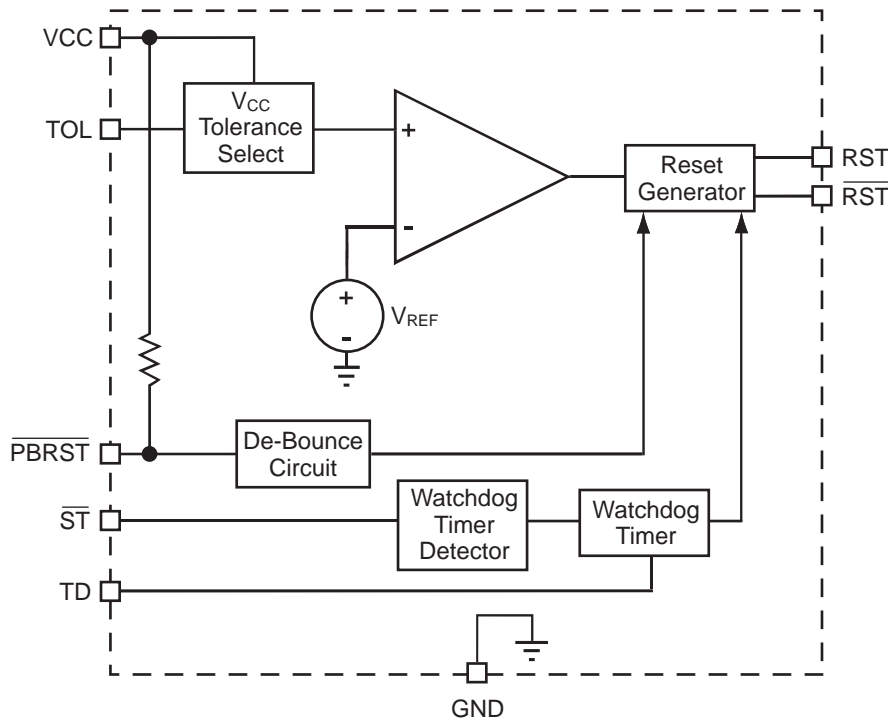

Applications Information

Power Monitor

The reset function monitors the V_{CC} supply to ensure a microprocessor is correctly reset and is powered up into a known condition following a power supply failure. RST and \overline{RST} will remain valid for V_{CC} voltages down to 1.4V.

The RST and \overline{RST} pins are asserted whenever V_{CC} drops below the reset threshold voltage. This voltage can be set by programming the TOL pin. Connecting TOL to V_{CC} sets the 10% tolerance of the V_{CC} supply (typically 4.37V for $V_{CC} = 5V$). Connecting TOL to GND sets the 5% tolerance of the V_{CC} supply (typically 4.62V for $V_{CC} = 5V$). The reset pin is guaranteed to remain asserted for a minimum period of 250ms after V_{CC} has risen above the reset threshold voltage. (See Figure 1.)

The \overline{RST} output is an open drain output. For correct operation, a pull-up resistor of 10k Ω should be connected between this output and V_{CC} .

Manual Reset

The \overline{PBRST} pin makes it possible to manually reset the system by either directly connecting a mechanical push-button between the \overline{PBRST} pin and GND or connecting to a logic low output. Internal de-bounce circuitry is provided to reduce the effect of noise glitches at the input. The signal should remain low for a minimum of 20ms for correct operation. Once the \overline{PBRST} signal is released (or goes to a logic high), \overline{RESET} (RESE \overline{T}) remains asserted for a minimum of 250ms.

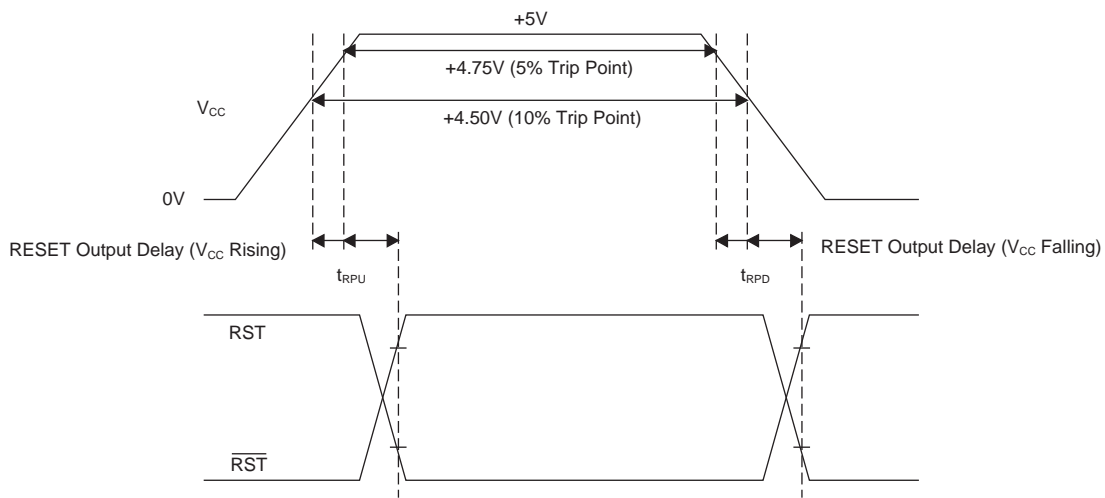

Figure 1: Reset Output Delay.

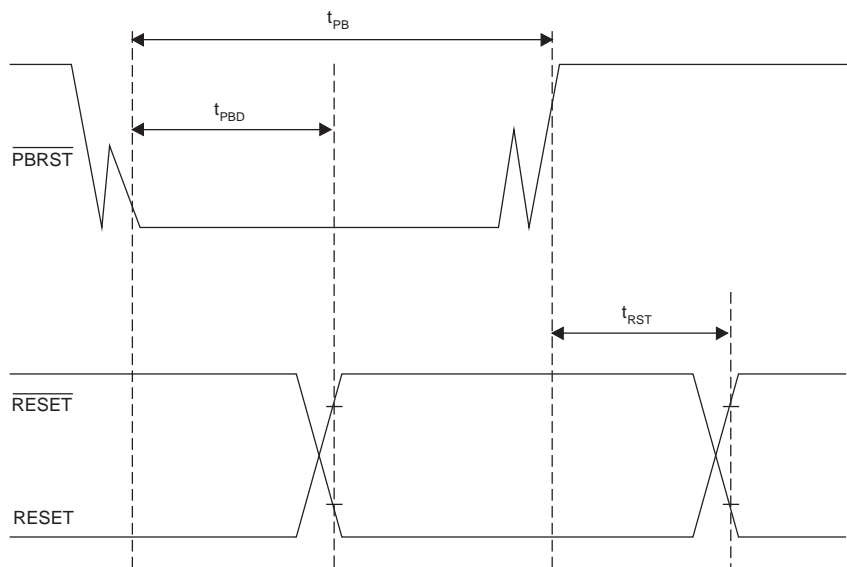

Figure 2: Push-Button Reset.

Watchdog Timer

The watchdog timer monitors the microprocessor to ensure that the system is functioning correctly. The \overline{ST} pin of the AAT3532 can be derived from the microprocessor data signals, address signals, and/or I/O signals. The watchdog timer function forces the \overline{RST} and \overline{RST} signals into the active state when the \overline{ST} input is not toggled by a pre-determined time. This time period is set by the logic state of the TD pin, as shown in Table 1. The timer

starts once the \overline{RST} signals become inactive. If the watchdog timer does not receive a high-to-low transition within the specified timeout period, then the \overline{RST} signals are activated for a minimum 250ms. In normal operation, the timer should receive a transition from the microprocessor within the timeout period, in which case the timer is reset and normal operation continues.

The AAT3532 will accept and recognize \overline{ST} pulses down to a minimum of 20ns wide.

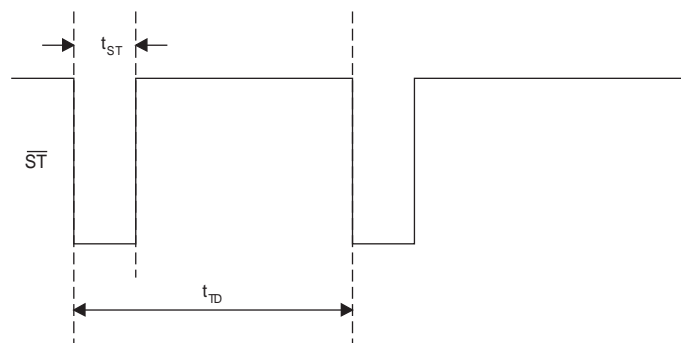

Figure 3: Watchdog Input.

Ordering Information

Package	Marking	Part Number (Tape and Reel) ¹
SOP-8	3532	AAT35321AS-T1



All AnalogicTech products are offered in Pb-free packaging. The term “Pb-free” means semiconductor products that are in compliance with current RoHS standards, including the requirement that lead not exceed 0.1% by weight in homogeneous materials. For more information, please visit our website at <http://www.analogictech.com/aboutus/quality.php>.

Package Information

SOP-8

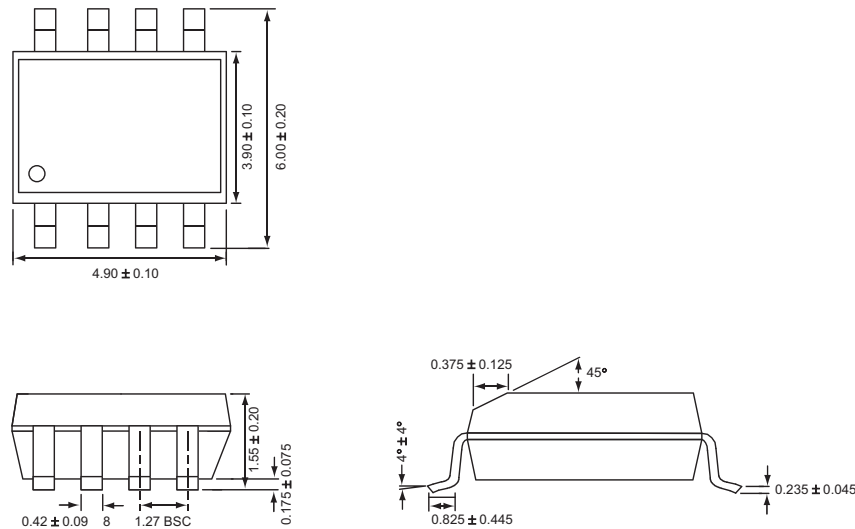

All dimensions in millimeters.

1. Sample stock is generally held on all part numbers listed in **BOLD**.

Advanced Analogic Technologies, Inc.
 3230 Scott Boulevard, Santa Clara, CA 95054
 Phone (408) 737-4600
 Fax (408) 737-4611



© Advanced Analogic Technologies, Inc. AnalogicTech cannot assume responsibility for use of any circuitry other than circuitry entirely embodied in an AnalogicTech product. No circuit patent licenses, copyrights, mask work rights, or other intellectual property rights are implied. AnalogicTech reserves the right to make changes to their products or specifications or to discontinue any product or service without notice. Except as provided in AnalogicTech's terms and conditions of sale, AnalogicTech assumes no liability whatsoever, and AnalogicTech disclaims any express or implied warranty relating to the sale and/or use of AnalogicTech products including liability or warranties relating to fitness for a particular purpose, merchantability, or infringement of any patent, copyright or other intellectual property right. In order to minimize risks associated with the customer's applications, adequate design and operating safeguards must be provided by the customer to minimize inherent or procedural hazards. Testing and other quality control techniques are utilized to the extent AnalogicTech deems necessary to support this warranty. Specific testing of all parameters of each device is not necessarily performed. AnalogicTech and the AnalogicTech logo are trademarks of Advanced Analogic Technologies Incorporated. All other brand and product names appearing in this document are registered trademarks or trademarks of their respective holders.