

General Description

The AAT3129 is a high efficiency charge pump DC/DC converter with tri-mode load switch (1X) fractional (1.5X) and doubling (2X) conversion for color LED applications. A single current source output provides a regulated current to drive R, G, and B LEDs via three internal switches. With a simple single wire serial bus, the RGB module can be easily controlled to display 4096 colors.

AnalogicTech's Advanced Simple Serial Control™ (AS²Cwire™) serial digital input is used to enable, disable, and set the duty cycle of each internal MOSFET switch. Low external parts count (two 1μF flying capacitors and two small bypass capacitors at V_{IN} and OUT) makes the AAT3129 ideally suited for small battery-powered applications.

The AAT3129 has a thermal management system to protect the device in the event of a short-circuit condition on any of the output pins. Built-in soft-start circuitry prevents excessive inrush current during start-up. High switching frequency enables the use of small external capacitors. A low current shutdown feature disconnects the load from V_{IN} and reduces quiescent current to less than 1μA.

The AAT3129 is available in a Pb-free, 12-pin TSOPJW package.

Features

- V_{IN} Range: 2.7V to 5.5V
- Common Anode RGB LED Control
- 4096 Color with Single Wire Digital Control
- 40mA to 180mA Fixed Current Source
- AS²Cwire Digital Brightness Control
- Low Noise Constant Frequency Operation
- Small Application Circuit
- Regulated Output Current
- No Inductors
- 1MHz Switching Frequency
- I_Q < 1μA in Shutdown
- 12-Pin TSOPJW Package

Applications

- Fashion RGBs
- Mobile Handsets
- MP3 Players
- PDAs
- Portable Devices
- RGB Color LEDs
- RGB Photo Flash
- Smart Phones

Typical Application

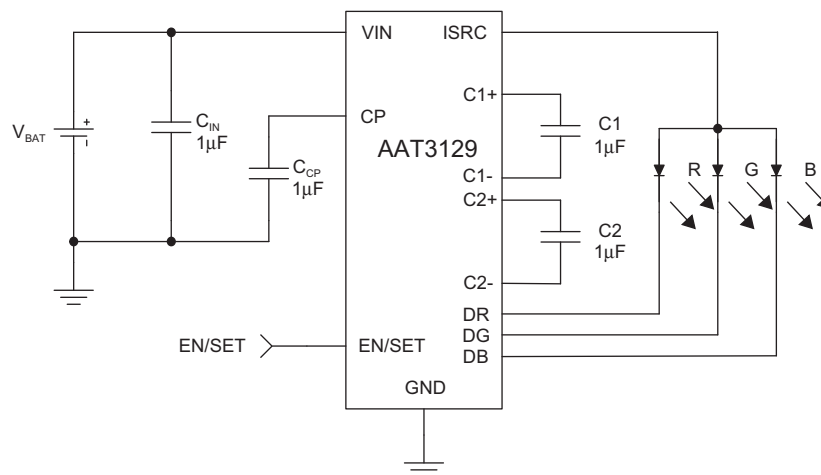

Pin Descriptions

Pin #	Symbol	Function
1	C2+	Flying capacitor 2 positive terminal. Connect a 1μF capacitor between C2+ and C2-.
2	CP	Charge pump output. Requires 1μF capacitor connected between this pin and ground.
3	C1-	Flying capacitor 1 negative terminal.
4	C1+	Flying capacitor 1 positive terminal. Connect a 1μF capacitor between C1+ and C1-.
5	ISRC	Current source output.
6	EN/SET	AS ² Cwire control pin.
7	DB	Open drain switch blue diode cathode.
8	DG	Open drain switch green diode cathode.
9	DR	Open drain switch red diode cathode.
10	GND	Ground.
11	IN	Input power supply. Requires 1μF capacitor connected between this pin and ground.
12	C2-	Flying capacitor 2 negative terminal.

Pin Configuration

**TSOPJW - 12
(Top View)**

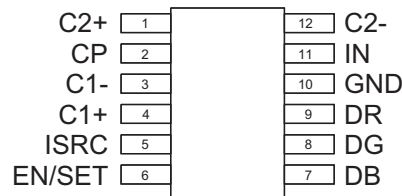

ChargePump™ High Efficiency 1X/1.5X/2X Charge Pump for RGB Color LED Applications
Absolute Maximum Ratings¹

Symbol	Description	Value	Units
V_{IN}	Input Voltage	-0.3 to 6	V
V_{CP}	Charge Pump Output	-0.3 to 6	V
$V_{EN/SET}$	EN/SET to GND Voltage	-0.3 to 6	V
$V_{EN/SET(MAX)}$	Maximum EN/SET to Input Voltage	0.3	V
T_J	Operating Junction Temperature Range	-40 to 150	°C
T_{LEAD}	Maximum Soldering Temperature (at leads, 10 sec)	300	°C

Thermal Information

Symbol	Description	Value	Units
P_D	Maximum Power Dissipation ^{2, 3}	625	mW
θ_{JA}	Thermal Resistance	160	°C/W

1. Stresses above those listed in Absolute Maximum Ratings may cause permanent damage to the device. Functional operation at conditions other than the operating conditions specified is not implied. Only one Absolute Maximum Rating should be applied at any one time.

2. Mounted on an FR4 board.

3. Derate 6.25mW/°C above 25°C.

ChargePump™ High Efficiency 1X/1.5X/2X Charge Pump for RGB Color LED Applications
Electrical Characteristics¹

$V_{IN} = 3.5V$, $C_{IN} = C_{CP} = C1 = C2 = 1\mu F$; $T_A = -40^\circ C$ to $+85^\circ C$. Unless otherwise noted, typical values are $T_A = 25^\circ C$.

Symbol	Description	Conditions	Min	Typ	Max	Units
Input Power Supply						
V_{IN}	Operation Range		2.7		5.5	V
I_{CC}	Operating Current	$3.0 \leq V_{IN} \leq 5.5$, CP = 1.5X, No Load Current		1	3	mA
I_{SHDN}	Shutdown Current	EN = 0			1	μA
I_{SRC}	Output Current Accuracy	$3.0 \leq V_{IN} \leq 5.5$	-5		5	%
Charge Pump						
T_S	Start-Up Delay Time			200		μs
F_{CLK}	Clock Frequency			1		MHz
η	Efficiency	$V_{IN} = 3.5V$		93		%
Switches						
$R_{DS(ON)}$	Switch On Resistance	$V_{IN} = 3.5V$, $T_A = 25^\circ C$			1.5	Ω
EN/ SET						
$V_{EN(L)}$	Enable Threshold Low	$V_{IN} = 2.7V$			0.4	V
$V_{EN(H)}$	Enable Threshold High	$V_{IN} = 5.5V$	1.4			V
$T_{EN/SET LO}$	EN/SET Low Time		0.3		75	μs
$T_{EN/SET HI MIN}$	Minimum EN/SET High Time			50		ns
T_{OFF}	EN/SET Off Timeout				500	μs
T_{LAT}	EN/SET Latch Timeout				500	μs
$I_{EN/SET}$	EN/SET Input Leakage	$V_{EN/SET} = 5.5V$, $V_{IN} = 5.5V$	-1		1	μA

1. The AAT3129 is guaranteed to meet performance specifications over the $-40^\circ C$ to $+85^\circ C$ operating temperature range and is assured by design, characterization, and correlation with statistical process controls.

Typical Characteristics

Turn-On to 1X Mode
($V_{IN} = 4.2V$; $I_{SRC} = 60mA$)

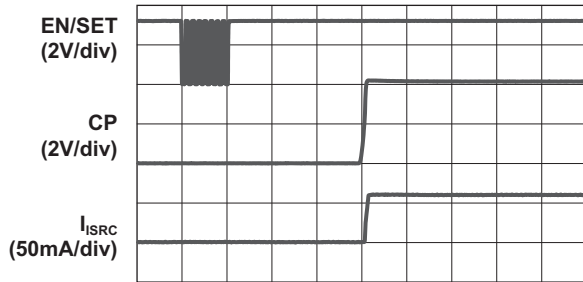

100μs/div

Turn-On to 1.5X Mode
($V_{IN} = 3.6V$; $I_{SRC} = 60mA$)

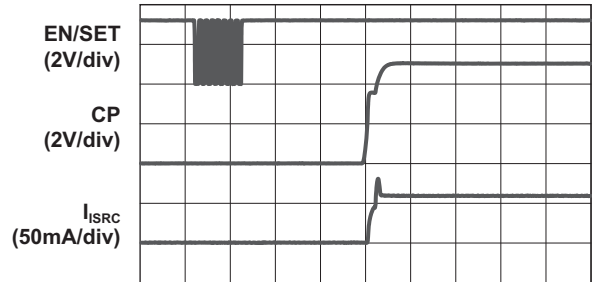

100μs/div

Turn-On to 2X Mode
($V_{IN} = 2.8V$; $I_{SRC} = 60mA$)

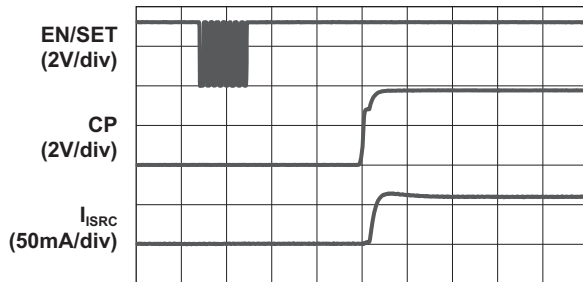

100μs/div

Turn-Off from 1.5X Mode
($V_{IN} = 3.6V$; Addr = 2; Data = 16)

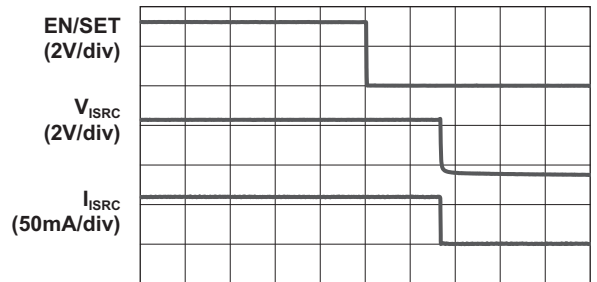

100μs/div

Typical Characteristics

Operating Characteristics
($V_{IN} = 4.2V$; DR, DB, and DG in 1X Mode)

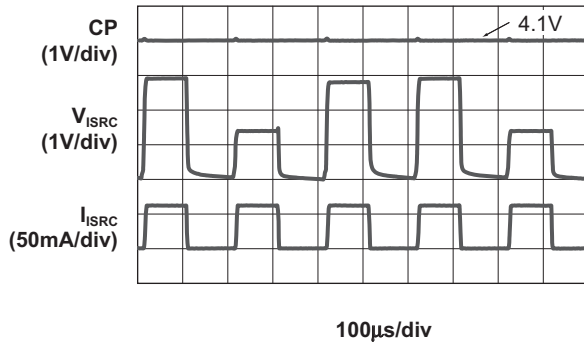

Operating Characteristics
($V_{IN} = 3.9V$; DR and DG in 1X Mode; DB in 1.5X Mode)

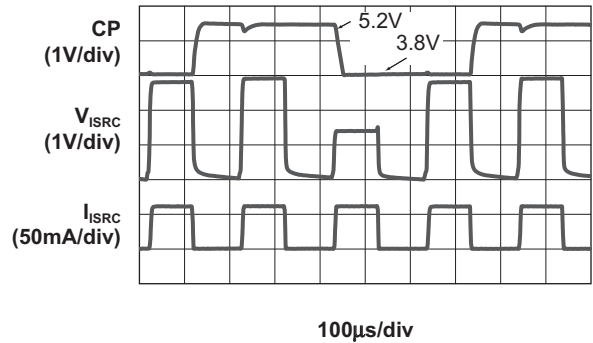

Operating Characteristics
($V_{IN} = 3.6V$; DR in 1X Mode; DG and DB in 1.5X Mode)

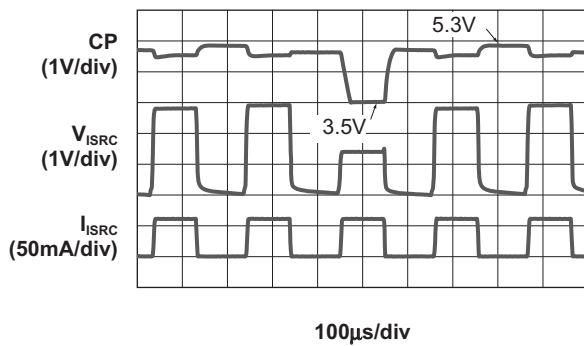

Line Response
(1X Mode; $I_{ISRC} = 60mA$)

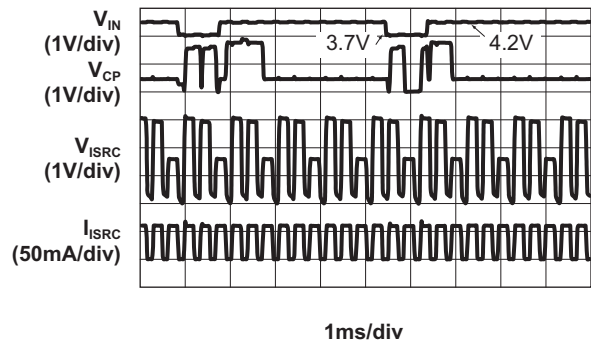

Line Response
(1X, 1.5X Mode; $I_{ISRC} = 60mA$)

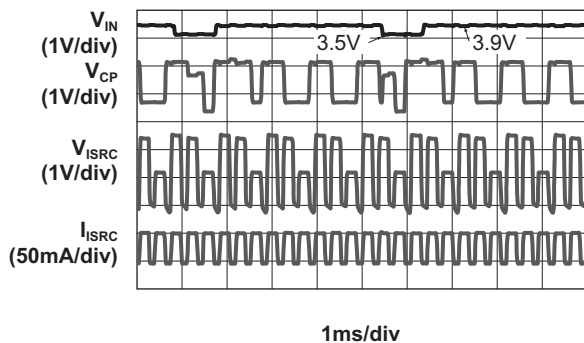

Typical Characteristics

Oscillator Frequency vs. Temperature

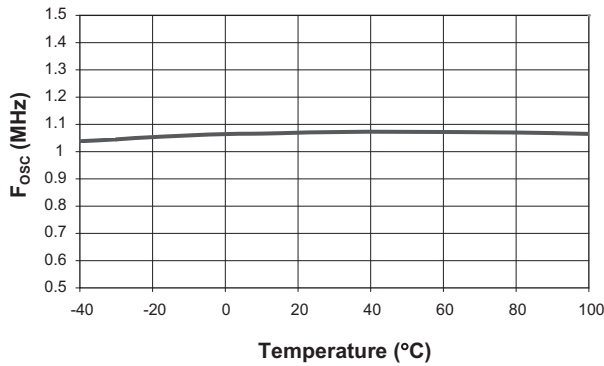

Shutdown Current vs. Temperature

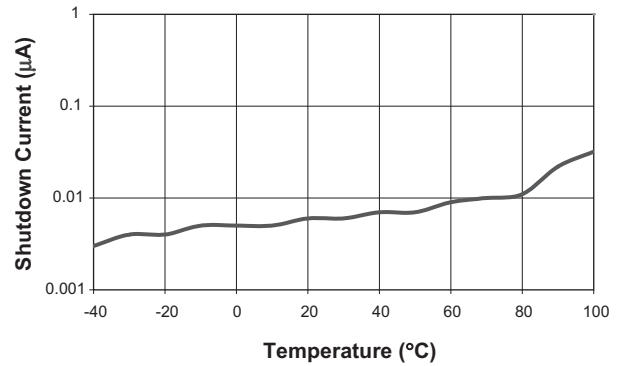

I_{ISRC} vs. V_{IN}
($V_F = 3.5V$)

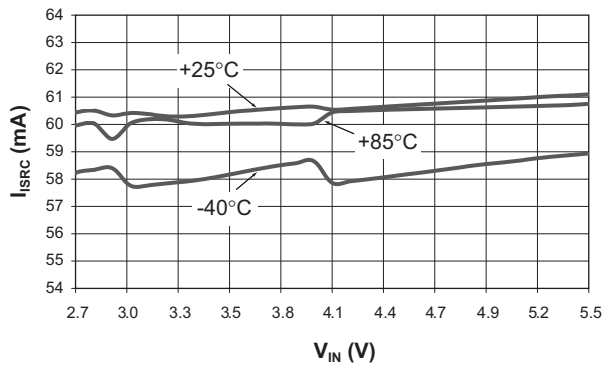

I_{ISRC} vs. V_F
($V_{IN} = 3.5V$)

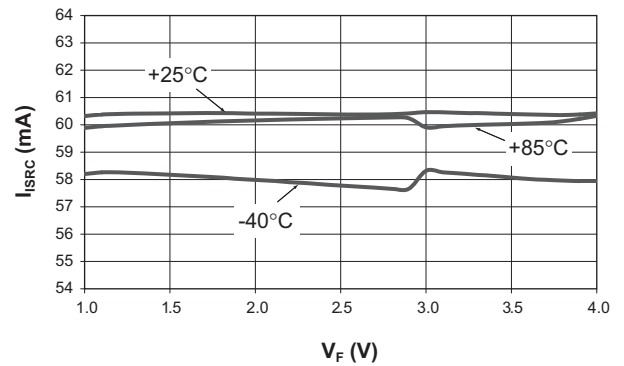

T_{LAT} vs. V_{IN}

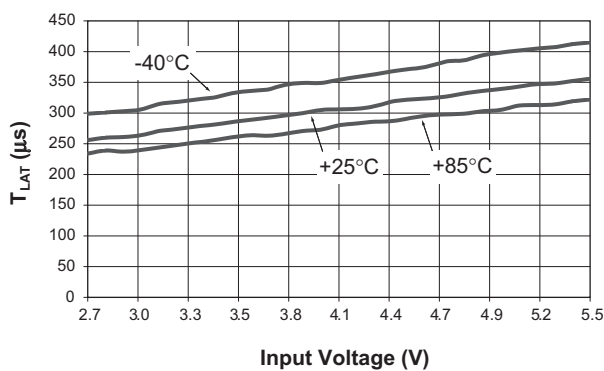

T_{OFF} vs. V_{IN}

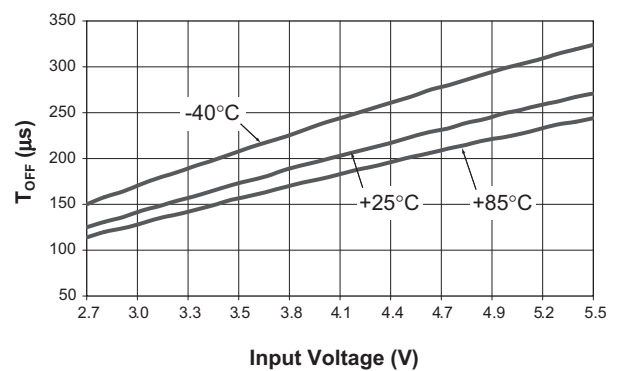

Typical Characteristics

Switch Resistance vs. Supply Voltage

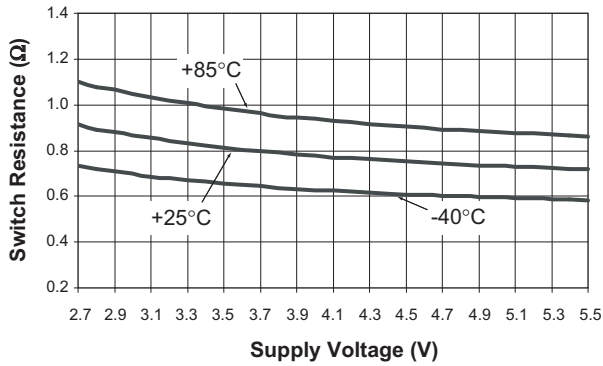

V_{IH} vs. V_{IN}

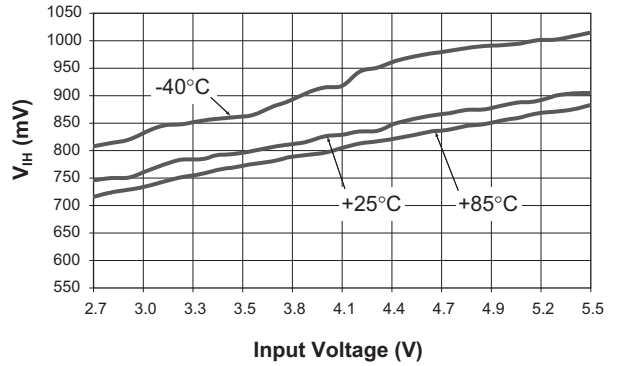

V_{IL} vs. V_{IN}

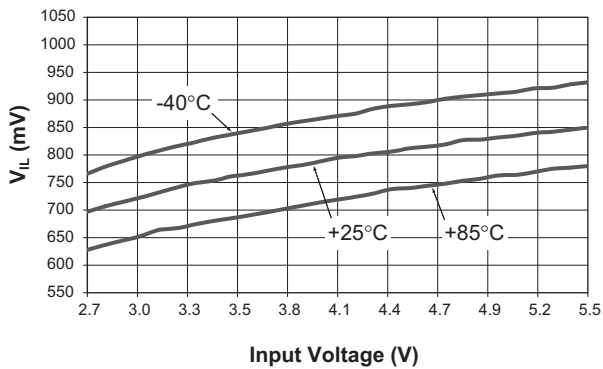

Functional Block Diagram

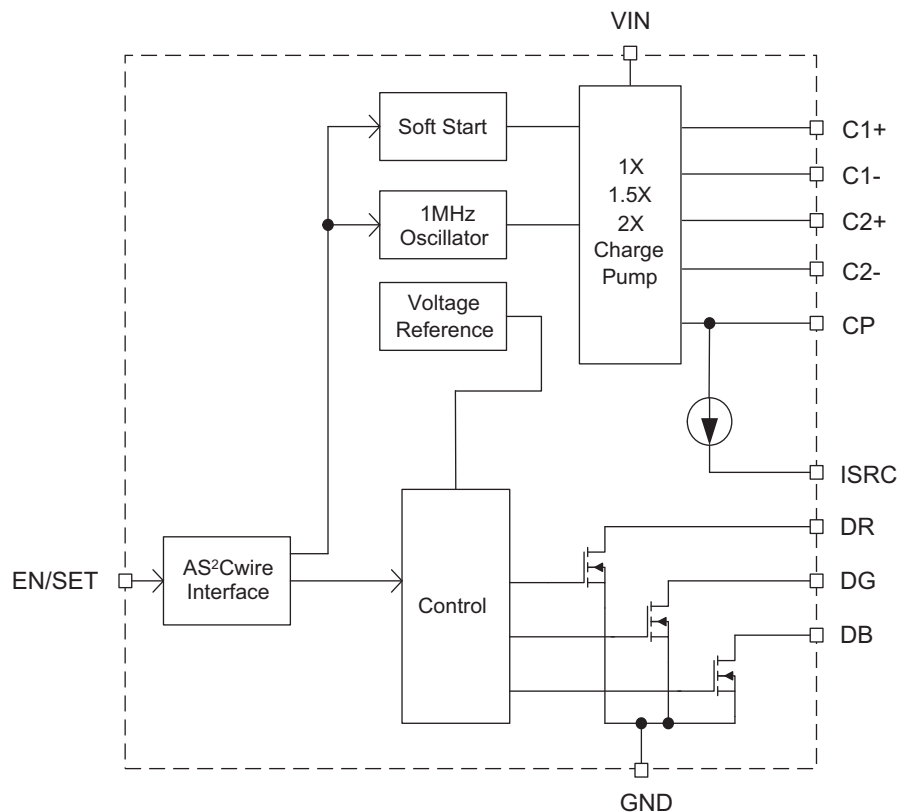

Functional Description

The AAT3129 is a tri-mode load switch (1X) and high efficiency (1.5X or 2X) charge pump device intended for fashion color LED lighting applications. To maximize power conversion efficiency, an internal sensing circuit monitors the voltage required on the constant current source output and sets the load switch and charge pump modes based on the input battery voltage and the current source output voltage. As the battery discharges over time, the AAT3129 charge pump is enabled when the current source output nears dropout. The charge pump initially starts in 1.5X mode. If the charge pump output drops enough for the current source output to

become close to dropout, the charge pump will automatically transition to 2X mode.

The AAT3129 requires only four external components: two $1\mu\text{F}$ ceramic capacitors for the charge pump flying capacitors (C_1 and C_2), one $1\mu\text{F}$ ceramic input capacitor (C_{IN}), and one $0.33\mu\text{F}$ to $1\mu\text{F}$ ceramic output capacitor (C_P).

The color and brightness of an RGB color LED is maintained by PWM signals, which are programmed via the AS²Cwire interface. The control block generates three gate drive PWM signals for the N-channel MOSFET switches. Please refer to the interface description and timing in the following section for details.

Applications Information

AS²Cwire Serial Interface

The Advanced Simple Serial Control digital interface is used to set the color, overall intensity, and method of update for the R, G, and B channels. The intensity for each channel is set by dedicated 4-bit registers giving each channel 16 levels of brightness and resulting in 4096 possible color combinations. In addition to the three color registers, there is an intensity register and a mode register. The intensity register sets the overall intensity and provides 16 global brightness levels. The mode register toggles the method of update between two possibilities. Depending on the mode register setting, the AAT3129 will update the R, G, and B channels immediately or update them only when the intensity register is updated.

AS²Cwire relies on the number of rising edges of the EN/SET pin to address and load the registers. AS²Cwire

latches data or address after the EN/SET pin has been held high for time T_{LAT} . Address or data is differentiated by the number of EN/SET rising edges. Since the data registers are 4 bits each, the differentiating number of pulses is 24 or 16, so that address 1 is signified by 17 rising edges, address 2 by 18 rising edges, and so forth. Data is set to any number of rising edges between 1 and including 16. A typical write protocol is a burst of EN/SET rising edges, signifying a particular address, followed by a pause with EN/SET held high for the T_{LAT} timeout period, a burst of rising edges signifying data, and a T_{LAT} timeout for the data registers. Once an address is set, then multiple writes to the corresponding data register are allowed.

When EN/SET is held low for an amount of time greater than T_{OFF} , the AAT3129 enters into shutdown mode and draws less than 1 μ A from the supply. Address 1 is the default address on the first rising edge after the AAT3129 has been disabled. When shutdown mode is entered, the Address and Data registers are reset to 1.

AS²Cwire Serial Interface Timing

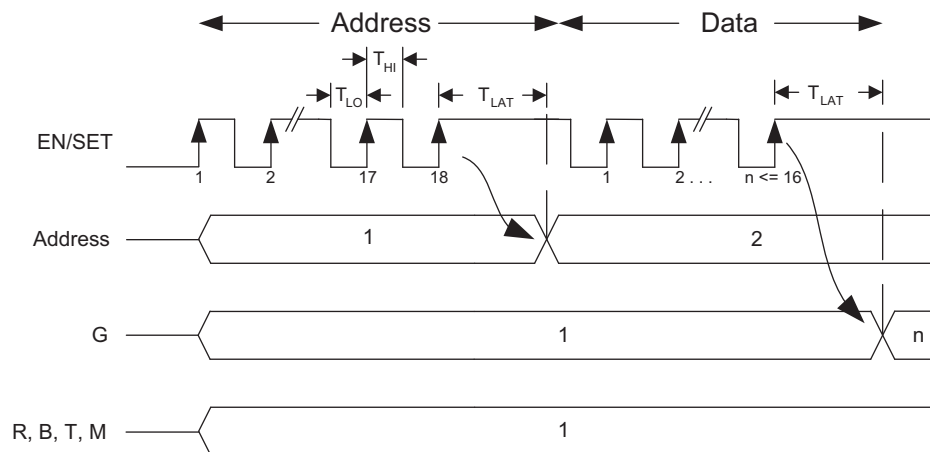

AS²Cwire Serial Interface Addressing

Address	EN/ SET Rising Edges	Data Register	Description
1	17	R	Red
2	18	G	Green
3	19	B	Blue
4	20	T	Intensity
5	21	M	Mode

Color Registers R, G, and B

The individual color brightness is set using the three R, G, and B registers. The data register contents determine the on-time for each color channel during a PWM cycle. The first level is 0, or off, and is set with a single EN/SET rising edge. This setting eliminates a given color from the spectrum. The remaining 15 levels progressively increase the brightness for a particular color by increasing that channel's on-time. Using the red channel as an example, the resulting on-time is

$$\text{on-time} = (R - 1) \cdot 128\mu\text{s}$$

where R is the data setting (from 1 to 16). The same applies to G and B.

Intensity Register T

The overall intensity level is set by the T register. Once a particular mixing of colors is set to produce the desired color, the overall intensity can be adjusted while keeping constant the ratio of colors to one another. The brightest level is set by programming the T register with 1 edge. Programming the T register with 16 edges produces the dimmest setting. The T register adjusts the overall intensity by controlling the PWM off-time. Under the dimmest

setting, the off-time is the longest. The off-time that results from the data in the T register is

$$\text{off-time} = (T - 1) \cdot 512\mu\text{s}$$

Mode Register M

The mode register determines the method of update for the R, G, and B channels. When the mode register is set to 1, the addressed color updates immediately. When the mode register is set to 2, the colors will update when the T register is written (synchronized updating).

Under immediate updating, an addressed channel will update as soon as new data has latched for it. Under synchronized updating, the channels that have been assigned new data will not update until data for the T register latches.

By using synchronized updating, discrete changes in color can be achieved. Synchronized updating allows the intensity for all three colors to be updated simultaneously. All three color registers can be loaded with new data prior to the update. Then, upon loading the T register, all three colors will change to their new states together. This allows a user to transition from one mixed color to another without having to traverse intermediate colors. Under immediate updating color changes can only be achieved serially, or one color at a time.

Diode Current Timing

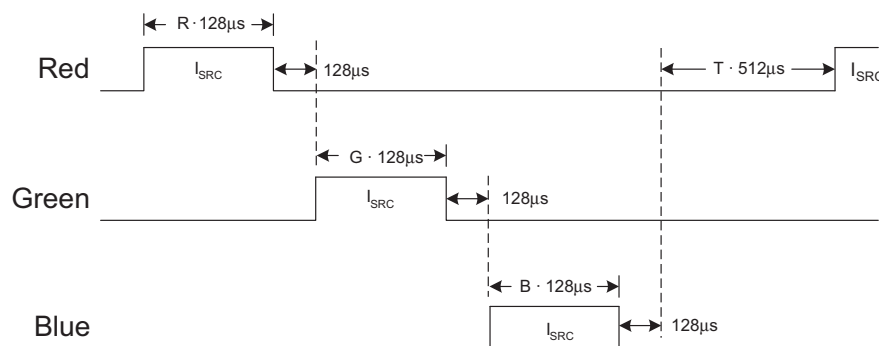

Mode Register Settings - Address 5

M Setting	Action
1	R, G, B, T Registers Latched Independently
2	R, G, B Registers Synchronized to T Register Latch

LED Current

The resulting DC current for each of the R, G, and B channels depends on the overall system settings. Using the overall settings, the current for a particular channel is calculated as

$$I_R = I_{SRC} \cdot \frac{R - 1}{4 \cdot (T - 1) + (R - 1) + (G - 1) + (B - 1) + CHLS_ON}$$

$$I_G = I_{SRC} \cdot \frac{G - 1}{4 \cdot (T - 1) + (R - 1) + (G - 1) + (B - 1) + CHLS_ON}$$

$$I_B = I_{SRC} \cdot \frac{B - 1}{4 \cdot (T - 1) + (R - 1) + (G - 1) + (B - 1) + CHLS_ON}$$

where I_{SRC} is the factory programmed current and $CHLS_ON$ is the number of channels programmed to operate. Whenever a channel is programmed to $Data = 1$, that channel is programmed to off and must be removed from the $CHLS_ON$ count.

Capacitor Selection

Careful selection of the four external capacitors C_{IN} , C_1 , C_2 , and C_{OUT} is important because they will affect turn-on time, output ripple, and transient performance. Optimum performance will be obtained when low equivalent series resistance (ESR) ceramic capacitors are used. In general, low ESR may be defined as less than $100m\Omega$. For best overall performance, $1\mu F$ capacitors are recommended. Depending on ripple requirements, the input and output capacitor values can be increased or decreased accordingly. If lower ripple is desired, increase the capacitor value. The peak-to-peak ripple seen at the input or output increases or decreases with capacitor size.

Capacitor Characteristics

Ceramic composition capacitors are highly recommended over all other types of capacitors for use with the AAT3129. Ceramic capacitors offer many advantages over their tantalum and aluminum electrolytic counterparts. A ceramic capacitor typically has very low ESR, is lowest cost, has a smaller PCB footprint, and is non-polarized. Low ESR ceramic capacitors help maximize charge pump transient response. Since ceramic capacitors are non-polarized, they are not prone to incorrect connection damage.

Equivalent Series Resistance

ESR is an important characteristic to consider when selecting a capacitor. ESR is a resistance internal to a capacitor that is caused by the leads, internal connections, size or area, material composition, and ambient temperature. Capacitor ESR is typically measured in milliohms for ceramic capacitors and can range to more than several ohms for tantalum or aluminum electrolytic capacitors.

Ceramic Capacitor Materials

Ceramic capacitors less than $0.1\mu F$ are typically made from NPO or C0G materials. NPO and C0G materials typically have tight tolerance and are stable over temperature. Larger capacitor values are typically composed of X7R, X5R, Z5U, or Y5V dielectric materials. Large ceramic capacitors, typically greater than $2.2\mu F$, are often available in low-cost Y5V and Z5U dielectrics, but capacitors greater than $1\mu F$ are typically not required for AAT3129 applications.

Capacitor area is another contributor to ESR. Capacitors that are physically large will have a lower ESR when compared to a smaller capacitor made from an equivalent material. These larger devices can improve circuit transient response when compared to an equal value capacitor in a smaller package size.

Layout Considerations

The AAT3129 is a high-performance device that operates with a high switching frequency. To ensure optimal device performance and accommodate the fast transients generated by the AAT3129 special attention should be given to the board layout.

The recommended layout is illustrated in Figure 1. The traces connecting C_1 and C_2 experience fast current transients. As a result, the trace lengths for C_1 and C_2 should be minimized by placing the components as closely as possible to the IC. This will minimize path resistance and reduce ringing due to the inductance associated with trace length. For best IC performance, C_{IN} and C_{OUT} are placed as closely as possible to the IN and CP pins and are connected to a solid ground.

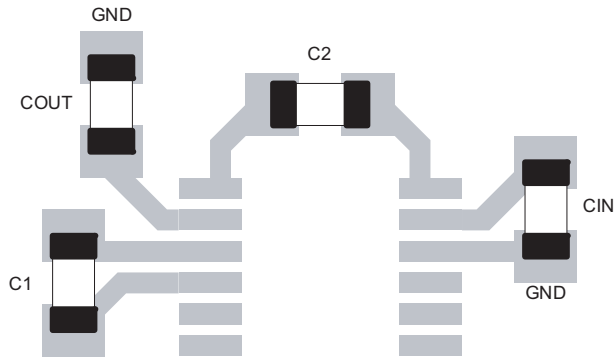

Figure 1: Optimal PCB Layout.

Ordering Information

Output Current	Package	Marking ¹	Part Number (Tape and Reel) ²
60mA	TSOPJW-12	NNXY	AAT3129ITP-60-T1



All AnalogicTech products are offered in Pb-free packaging. The term “Pb-free” means semiconductor products that are in compliance with current RoHS standards, including the requirement that lead not exceed 0.1% by weight in homogeneous materials. For more information, please visit our website at <http://www.analogictech.com/aboutus/quality.php>.

Package Information

TSOPJW -12

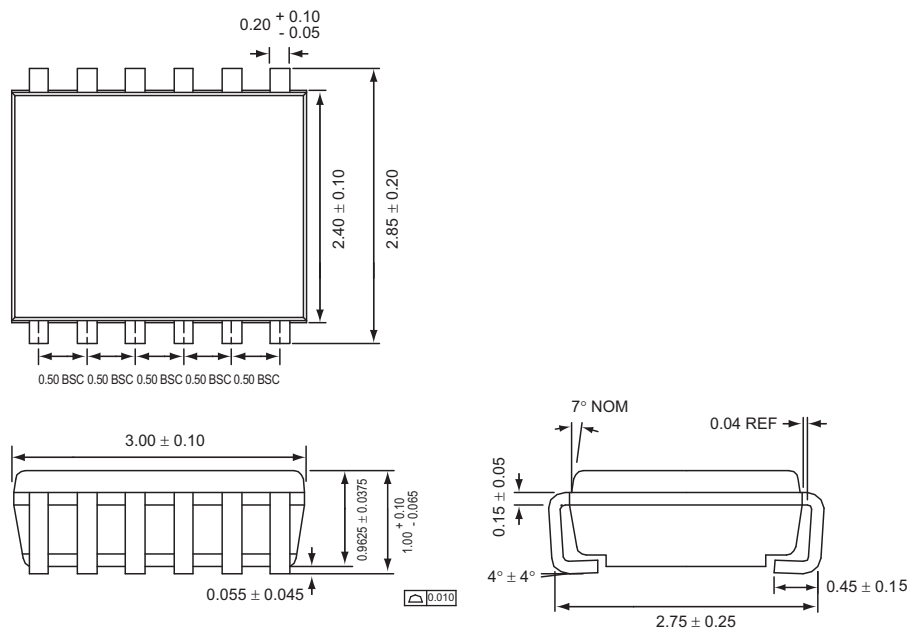

All dimensions in millimeters.

1. XYY = assembly and date code.
2. Sample stock is held on part numbers listed in **BOLD**.

Advanced Analogic Technologies, Inc.
 3230 Scott Boulevard, Santa Clara, CA 95054
 Phone (408) 737-4600
 Fax (408) 737-4611



© Advanced Analogic Technologies, Inc. AnalogicTech cannot assume responsibility for use of any circuitry other than circuitry entirely embodied in an AnalogicTech product. No circuit patent licenses, copyrights, mask work rights, or other intellectual property rights are implied. AnalogicTech reserves the right to make changes to their products or specifications or to discontinue any product or service without notice. Except as provided in AnalogicTech's terms and conditions of sale, AnalogicTech assumes no liability whatsoever, and AnalogicTech disclaims any express or implied warranty relating to the sale and/or use of AnalogicTech products including liability or warranties relating to fitness for a particular purpose, merchantability, or infringement of any patent, copyright or other intellectual property right. In order to minimize risks associated with the customer's applications, adequate design and operating safeguards must be provided by the customer to minimize inherent or procedural hazards. Testing and other quality control techniques are utilized to the extent AnalogicTech deems necessary to support this warranty. Specific testing of all parameters of each device is not necessarily performed. AnalogicTech and the AnalogicTech logo are trademarks of Advanced Analogic Technologies Incorporated. All other brand and product names appearing in this document are registered trademarks or trademarks of their respective holders.