

WFH Series

Aluminum Housed Wirewound Power

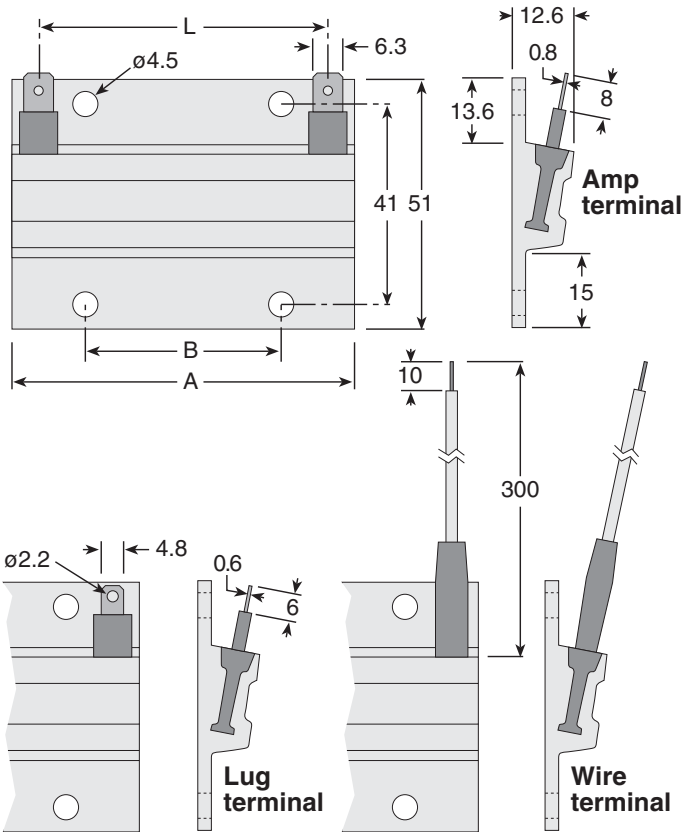

Type	Power Rating* (watts)	Resistance Range (Ω)	Dimension (mm)		
			A	B	L
WFH90	90	0.22Ω - 6.8K	70	39.7	53
WFH160	160	0.47Ω-18K	140	80	123
WFH230	230	0.82Ω-27K	210	2x 80	193
WFH330	330	1Ω - 39K	280	2x 100	263

*at 40°C base plate temperature

DESIGNING

The following equations are applied in the dimensioning of the resistors at stationary load. If more information is required please consult Ohmite. It is assumed that the air around the resistors is stationary (worst case). See ohmite.com for more examples.

1. WFH is mounted on a heat sink:

- A. The thermal resistance R_{TH} of the heat sink is known,
 $T = W_{MAX} \times (R_{TH4} + R_{TH})$
 Check that:
 $T_{MAX} = W_{MAX} \times (R_{TH} + R_{TH3} + R_{TH1}) + T_{AMB} < 220^{\circ}C$
- B. The Temperature of the Heat Sink is known,
 $T = W_{MAX} \times R_{TH4} + T_H$
 Check that:
 $T_{MAX} = W_{MAX} \times (R_{TH1} + R_{TH3}) + T_H < 220^{\circ}C$

2. WFH is mounted without a heat sink:

- Check that:
 $T_{MAX} = W_{MAX} \times (R_{TH1} + R_{TH2}) + T_{AMB} < 220^{\circ}C$

Where:

- W_{MAX} = Maximum required load in resistor
 T_{MAX} = Maximum hot spot temperature requested in resistor ($T_{MAX} < 220^{\circ}C$) The lower T_{MAX} the higher reliability and lifetime.
 T_{AMB} = Ambient temperature
 R_{TH} = Thermal resistance. Refer to table Thermal resistances
 T_H = Heat sink temperature (chassis).
 T = Temperature on top of the Aluminum profile.

Ohmite's new flat core winding technology allows for wire-wound heatsinkable resistors affording a very low profile, and superior thermal transfer characteristics when compared to conventional aluminum housed wirewound resistors. Close mounting of heat sensitive components is possible due to only a slight rise of the temperature on the aluminum profile. No heat sink compound is required because of large mounting surface.

FEATURES

- Solder, wire and "Fast-On" Termination
- More resistors in one profile possible
- Custom wire lengths available

SPECIFICATIONS

- Power rating:** 90W-330W
Resistance tolerance: $\pm 5\%$, $\pm 10\%$
Temperature Coefficients:
 Normal: 50ppm - 150ppm
 Low ohmic values: 400ppm
Dielectric strength: 2500 VAC peak
Working voltage: 1200 VAC
Test voltage: 6000 VAC
Lead wire: (wire terminal version only): XLPE, 600V, 125C, 18 AWG stranded
Insulation: Silicone Rubber & Mica. The Silicone is UL-recognised (UL 94 HB) to a working temperature of 220°C. Temperatures of up to 300°C can be endured for shorter periods. This may however cause an expansion of the silicone rubber with a possibility of reducing the dielectric strength.

POWER DISSIPATION

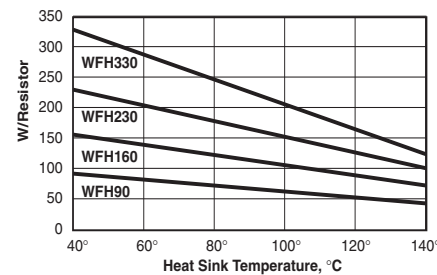

This graph shows the maximum wattage rating for each possible resistor of standard size corresponding to the heat sink temperature. It is assumed that all resistors are equally loaded.

THERMAL RESISTANCES

Thermal Resistance ($^{\circ}C/W$) between different measuring points

	WFH90	WFH160	WFH230	WFH330
R_{TH1}	2	1	0.75	0.5
R_{TH2}	6.8	3.9	2.75	2
R_{TH3}	0.1	0.05	0.03	0.02
R_{TH4}	0.3	0.17	0.1	0.085

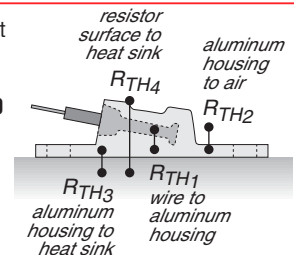

ORDERING INFORMATION

WFH160LR47KE-				RoHS Compliant
Series	Wattage at 40°C base plate temp.	Terminal Type L = lug terminals A = amp terminals W = 30cm insulated wire cable 18AWG	Ohms R47= 0.47Ω	Tolerance J = 5% K = 10%

THIS PRODUCT IS DESIGNED FOR USE WITH PROPER HEATSINKING.

Maximum base plate temperature of the resistor must be monitored and kept within specified limits to establish the power rating. Best technique is to attach a thermocouple to the side of the base plate of the resistor. Temperature of plastic housing or heat sink cannot be used to establish rating of the resistor.

STANDARD PART NUMBERS FOR WFH SERIES

WFH90L4R7KE	WFH160LR47KE	WFH160L1K0JE	WFH230L100JE	WFH330L50RJE
WFH90L10RKE	WFH160L1R0KE	WFH160L5K0JE	WFH230L150JE	WFH330L75RJE
WFH90L25RJE	WFH160L2R0KE	WFH160L10KJE	WFH230L250JE	WFH330L100JE
WFH90L50RJE	WFH160L10RKE	WFH230L1R0KE	WFH230L1K0JE	WFH330L150JE
WFH90L100JE	WFH160L27RJE	WFH230L2R0KE	WFH230L1K5JE	WFH330L250JE
WFH90L470JE	WFH160L50RJE	WFH230L5R0KE	WFH230L2K5JE	WFH330L1K0JE
WFH90L750JE	WFH160L75RJE	WFH230L10RKE	WFH330L1R0KE	WFH330L5K0JE
WFH90L1K0JE	WFH160L100JE	WFH230L27RJE	WFH330L2R0KE	WFH330L10KJE
WFH90L2K7JE	WFH160L150JE	WFH230L50RJE	WFH330L10RKE	
WFH90L5K0JE	WFH160L250JE	WFH230L75RJE	WFH330L27RJE	