

**LE** series Radial Lead Type, Ultra-low ESR



- Ultra-low ESR, High ripple current.
- Load life of 2000 hours at 105°C.
- Radial lead type :  
Lead free flow soldering condition correspondence
- Compliant to the RoHS directive (2002/95/EC).



■ Specifications

Item	Performance Characteristics		
Category Temperature Range	-55 to +105°C		
Rated Voltage Range	2.5 to 6.3V		
Rated Capacitance Range	470 to 1500μF		
Capacitance Tolerance	±20% at 120Hz, 20°C		
Tangent of loss angle (tan δ)	Less than or equal to the specified value at 120Hz, 20°C		
ESR (※ 1)	Less than or equal to the specified value at 100kHz, 20°C		
Leakage Current (※ 2)	Less than or equal to the specified value. After 2 minutes' application of rated voltage at 20°C		
Temperature Characteristics (Max.Impedance Ratio)	Z+105°C / Z+20°C ≤ 1.25 (100kHz) Z-55°C / Z+20°C ≤ 1.25		
Endurance	The specifications listed at right shall be met when the capacitors are restored to 20°C after the rated voltage is applied for 2000 hours at 105°C.	Capacitance change	Within ± 20% of the initial capacitance value (※ 3)
		tan δ	150% or less than the initial specified value
		ESR (※ 1)	150% or less than the initial specified value
		Leakage current (※ 2)	Less than or equal to the initial specified value
Damp Heat (Steady State)	The specifications listed at right shall be met when the capacitors are restored to 20°C after the rated voltage is applied for 1000 hours at 60°C, 90% RH.	Capacitance change	Within ± 20% of the initial capacitance value (※ 3)
		tan δ	150% or less than the initial specified value
		ESR (※ 1)	150% or less than the initial specified value
		Leakage current (※ 2)	Less than or equal to the initial specified value
Resistance to Soldering Heat	After soldering the capacitor under the soldering conditions prescribed here as preheat at 150 to 200°C for 60 to 180 seconds and peak temperature at 265°C for 10 seconds or less, the capacitor shall meet the specifications listed at right, provided that its temperature profile is measured at both of terminal ends facing the soldering side.	Capacitance change	Within ± 10% of the initial capacitance value (※ 3)
		tan δ	130% or less than the initial specified value
		ESR (※ 1)	130% or less than the initial specified value
		Leakage current (※ 2)	Less than or equal to the initial specified value
Marking	Navy blue print on the case top		

- ※ 1 ESR should be measured at both of the terminal ends closest to the capacitor body.
- ※ 2 Conditioning : If any doubt arises, measure the leakage current after the voltage treatment of applying DC rated voltage continuously to the capacitor for 120 minutes at 105°C.
- ※ 3 Initial value : The value before test of examination of resistance to soldering.

■ Dimensions

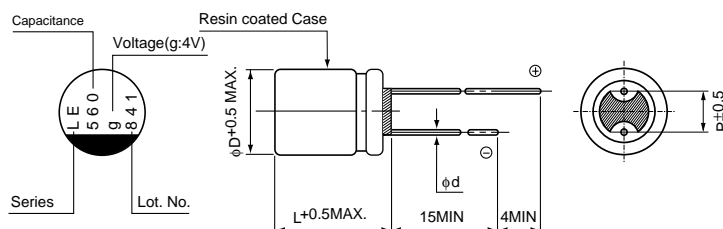

	(mm)		
Size	φ8 × 9L	φ8 × 12L	φ10 × 13L
φD	8.0	8.0	10.0
L	8.5	11.5	12.5
P	3.5	3.5	5.0
φd	0.6	0.6	0.6

Voltage				
V	2.5	4	6.3	
Code	e	g	j	

Please refer to page 20 about the end seal configuration.

Type numbering system (Example : 4V 560μF)

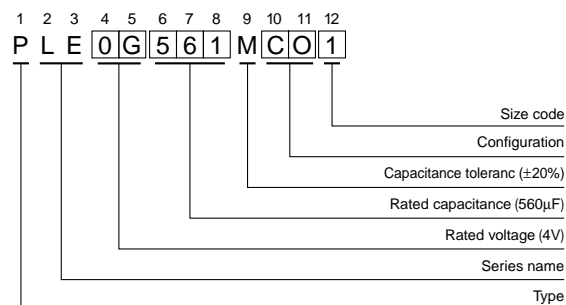

● Dimension table in next page.

**LE** series

■ Standard Ratings

Rated Voltage (V) Code	Surge Voltage (V)	Rated Capacitance (μF)	Case Size φD × L (mm)	tan δ	Leakage Current (μA)	ESR (mΩ) (at 100kHz 20°C)	Rated Ripple (mArms)	Part Number
2.5 (0E)	2.8	560	8 × 9	0.08	280	5	6100	PLE0E561MCO1
		820	▲ 8 × 9	0.08	410	5	6300	PLE0E821MCO6
		820	8 × 12	0.08	410	5	6600	PLE0E821MDO1
		1000	10 × 13	0.08	500	5	7100	PLE0E102MDO1
		1500	10 × 13	0.08	750	5	7300	PLE0E152MDO1
4 (0G)	4.6	560	8 × 9	0.08	448	5	6000	PLE0G561MCO1
		680	8 × 12	0.08	544	5	6500	PLE0G681MDO1
		820	10 × 13	0.08	656	5	7000	PLE0G821MDO1
		1200	10 × 13	0.08	960	5	7200	PLE0G122MDO1
6.3 (0J)	7.2	470	8 × 12	0.08	592	5	6400	PLE0J471MDO1
		680	10 × 13	0.08	857	5	6700	PLE0J681MDO1
		820	10 × 13	0.08	1033	5	6800	PLE0J821MDO1

Rated ripple current (mArms) at 105° C 100kHz

No marked, [1] will be put at 12th digit of type numbering system.  
 ▲ : In this case, [6] will be put at 12th digit of type numbering system.

- Taping specifications are given in page 20, 21, 22.
- Please refer to page 3 for the minimum order quantity.