



8-Mbit (512K x 16) Static RAM

Features

- Very high speed: 55 ns
- Wide voltage range: 1.65 V–2.25 V
- Pin compatible with CY62157DV18 and CY62157DV20
- Ultra low standby power
 - Typical Standby current: 2 μA
 - Maximum Standby current: 8 μA
- Ultra low active power
 - Typical active current: 1.8 mA at f = 1 MHz
- Easy memory expansion with \overline{CE}_1 , CE_2 and \overline{OE} features
- Automatic power down when deselected
- Complementary metal oxide semiconductor (CMOS) for optimum speed and power
- Available in Pb-free 48-ball very fine-pitch ball grid array (VFBGA) package

Functional Description

The CY62157EV18 is a high performance CMOS static RAM organized as 512K words by 16 bits. This device features advanced circuit design to provide ultra low active current. This is ideal for providing More Battery Life™ (MoBL®) in portable applications such as cellular telephones. The device also has an

automatic power down feature that significantly reduces power consumption when addresses are not toggling. The device can also be put into standby mode when deselected (\overline{CE}_1 HIGH or CE_2 LOW or both \overline{BHE} and \overline{BLE} are HIGH). The input and output pins (I/O_0 through I/O_{15}) are placed in a high impedance state when:

- Deselected (\overline{CE}_1 HIGH or CE_2 LOW)
- Outputs are disabled (\overline{OE} HIGH)
- Both Byte High Enable and Byte Low Enable are disabled (\overline{BHE} , \overline{BLE} HIGH) or
- Write operation is active (\overline{CE}_1 LOW, CE_2 HIGH and \overline{WE} LOW).

Write to the device by taking Chip Enables (\overline{CE}_1 LOW and CE_2 HIGH) and Write Enable (\overline{WE}) input LOW. If Byte Low Enable (\overline{BLE}) is LOW, then data from I/O pins (I/O_0 through I/O_7), is written into the location specified on the address pins (A_0 through A_{18}). If Byte High Enable (\overline{BHE}) is LOW, then data from I/O pins (I/O_8 through I/O_{15}) is written into the location specified on the address pins (A_0 through A_{18}).

Read from the device by taking Chip Enables (\overline{CE}_1 LOW and CE_2 HIGH) and Output Enable (\overline{OE}) LOW while forcing the Write Enable (\overline{WE}) HIGH. If Byte Low Enable (\overline{BLE}) is LOW, then data from the memory location specified by the address pins appear on I/O_0 to I/O_7 . If Byte High Enable (\overline{BHE}) is LOW, then data from memory appears on I/O_8 to I/O_{15} . See the “Truth Table” on page 11 for a complete description of read and write modes.

Product Portfolio

Product	V_{CC} Range (V)			Speed (ns)	Power Dissipation					
					Operating I_{CC} , (mA)				Standby, I_{SB2} (μA)	
					f = 1MHz		f = f_{max}			
Min	Typ ^[1]	Max	Typ ^[1]	Max	Typ ^[1]	Max	Typ ^[1]	Max		
CY62157EV18	1.65	1.8	2.25	55	1.8	3	18	25	2	8

Note

1. Typical values are included for reference only and are not guaranteed or tested. Typical values are measured at $V_{CC} = V_{CC(typ)}$, $T_A = 25$ °C.

Logic Block Diagram

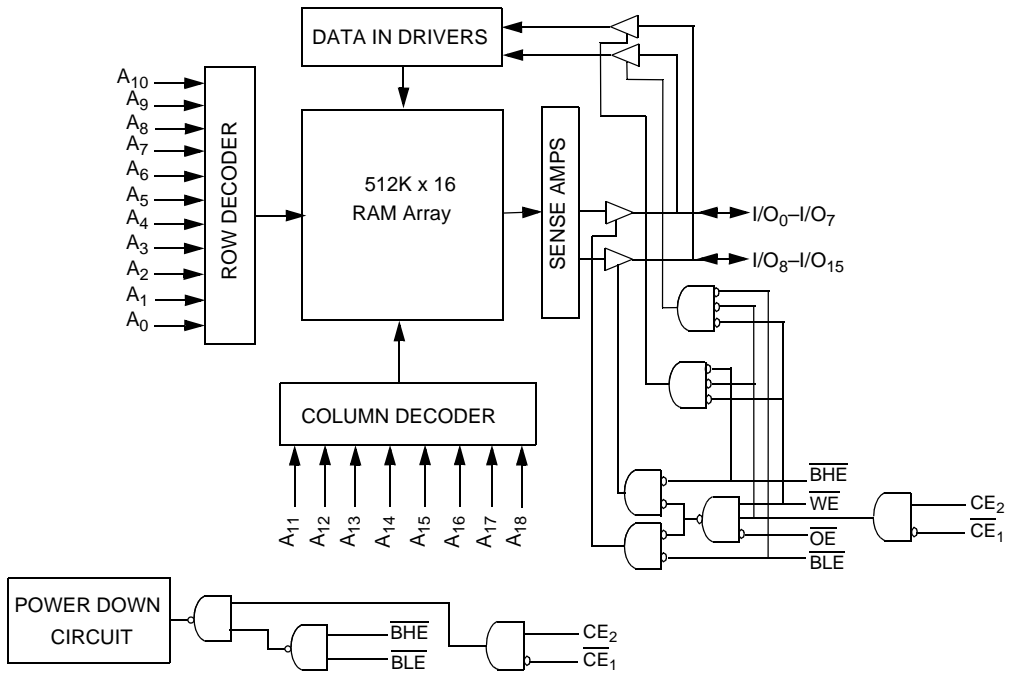

Contents

Pin Configuration	4	Ordering Information	12
Maximum Ratings	5	Ordering Code Definitions	12
Operating Range	5	Package Diagrams	13
Electrical Characteristics	5	Acronyms	14
Capacitance	5	Document Conventions	14
Thermal Resistance	6	Units of Measure	14
AC Test Loads and Waveforms	6	Document History	15
Data Retention Characteristics	6	Sales, Solutions, and Legal Information	16
Data Retention Waveform	6	Worldwide Sales and Design Support	16
Switching Characteristics	7	Products	16
Switching Waveforms	8	PSoC Solutions	16
Truth Table	11		

Pin Configuration ^[2]

48-ball VFBGA
Top View

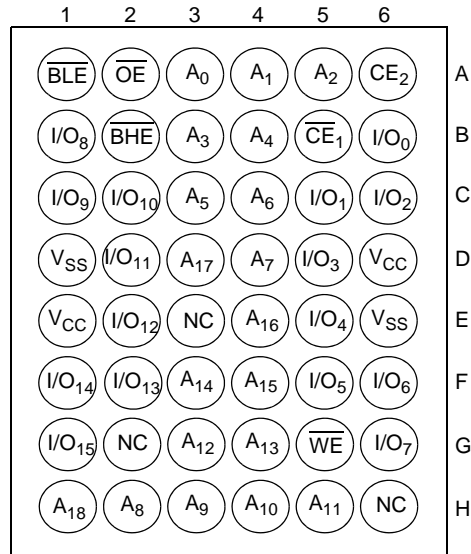

Note
2. NC pins are not connected on the die.

Maximum Ratings

Exceeding maximum ratings may shorten the useful life of the device. User guidelines are not tested.

Storage temperature -65 °C to + 150 °C

Ambient temperature with power applied -55 °C to + 125 °C

Supply voltage to ground potential -0.2 V to 2.45 V ($V_{CCmax} + 0.2$ V)

DC voltage applied to outputs in High-Z state ^[3, 4] -0.2 V to 2.45 V ($V_{CCmax} + 0.2$ V)

DC input voltage ^[3, 4] -0.2 V to 2.45 V ($V_{CCmax} + 0.2$ V)

Output current into outputs (LOW) 20 mA

Static discharge voltage > 2001 V (in accordance with MIL-STD-883, Method 3015)

Latch-up current > 200 mA

Operating Range

Device	Range	Ambient Temperature	V_{CC} ^[5]
CY62157EV18LL	Industrial	-40 °C to +85 °C	1.65 V to 2.25 V

Electrical Characteristics (Over the Operating Range)

Parameter	Description	Test Conditions		55 ns			Unit
				Min	Typ ^[6]	Max	
V_{OH}	Output HIGH voltage	$I_{OH} = -0.1$ mA	$V_{CC} = 1.65$ V	1.4	–	–	V
V_{OL}	Output LOW voltage	$I_{OL} = 0.1$ mA	$V_{CC} = 1.65$ V	–	–	0.2	V
V_{IH}	Input HIGH voltage	$V_{CC} = 1.65$ V to 2.25 V		1.4	–	$V_{CC} + 0.2$ V	V
V_{IL}	Input LOW voltage	$V_{CC} = 1.65$ V to 2.25 V		-0.2	–	0.4	V
I_{IX}	Input leakage current	$GND \leq V_I \leq V_{CC}$		-1	–	+1	μ A
I_{OZ}	Output leakage current	$GND \leq V_O \leq V_{CC}$, output disabled		-1	–	+1	μ A
I_{CC}	V_{CC} operating supply current	$f = f_{max} = 1/t_{RC}$	$V_{CC} =$	–	18	25	mA
		$f = 1$ MHz	$V_{CC(max)}$ $I_{OUT} = 0$ mA CMOS levels	–	1.8	3	mA
I_{SB1} ^[7]	Automatic CE power down current—CMOS inputs	$\overline{CE}_1 \geq V_{CC} - 0.2$ V or $CE_2 \leq 0.2$ V $V_{IN} \geq V_{CC} - 0.2$ V, $V_{IN} \leq 0.2$ V) $f = f_{max}$ (address and data only), $f = 0$ (\overline{OE} , \overline{WE} , BHE and BLE), $V_{CC} = V_{CC(max)}$.		–	2	8	μ A
I_{SB2} ^[7]	Automatic CE power down current—CMOS Inputs	$\overline{CE}_1 \geq V_{CC} - 0.2$ V or $CE_2 \leq 0.2$ V, $V_{IN} \geq V_{CC} - 0.2$ V or $V_{IN} \leq 0.2$ V, $f = 0$, $V_{CC} = V_{CC(max)}$.		–	2	8	μ A

Capacitance

Parameter ^[8]	Description	Test Conditions	Max	Unit
C_{IN}	Input capacitance	$T_A = 25$ °C, $f = 1$ MHz, $V_{CC} = V_{CC(typ)}$	10	pF
C_{OUT}	Output capacitance		10	pF

Notes

- $V_{IL(min)}$ = -2.0 V for pulse durations less than 20 ns.
- $V_{IH(max)}$ = $V_{CC} + 0.5$ V for pulse durations less than 20 ns.
- Full Device AC operation assumes a 100 μ s ramp time from 0 to V_{CC} (min) and 200 μ s wait time after V_{CC} stabilization.
- Typical values are included for reference only and are not guaranteed or tested. Typical values are measured at $V_{CC} = V_{CC(typ)}$, $T_A = 25$ °C
- Chip enable (CE) and byte enables (BHE and BLE) need to be tied to CMOS levels to meet the $I_{SB1}/I_{SB2}/I_{CCDR}$ spec. Other inputs can be left floating.
- Tested initially and after any design or process changes that may affect these parameters.

Thermal Resistance

Parameter ^[9]	Description	Test Conditions	BGA	Unit
Θ_{JA}	Thermal resistance (Junction to ambient)	Still air, soldered on a 3 x 4.5 inch, two-layer printed circuit board	72	°C/W
Θ_{JC}	Thermal resistance (Junction to case)		8.86	°C/W

AC Test Loads and Waveforms

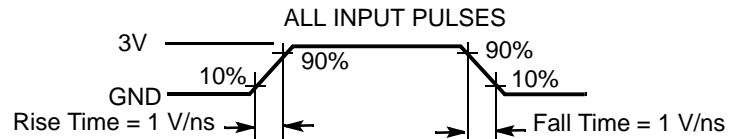
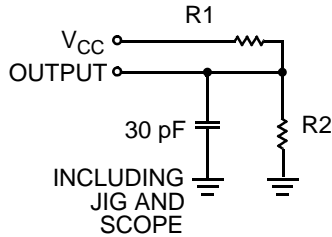

Equivalent to: THEVENIN EQUIVALENT



Parameters	Value	Unit
R1	13500	Ω
R2	10800	Ω
R_{TH}	6000	Ω
V_{TH}	0.80	V

Data Retention Characteristics (Over the Operating Range)

Parameter	Description	Conditions	Min	Typ ^[10]	Max	Unit
V_{DR}	V_{CC} for Data retention		1.0	–	–	V
I_{CCDR} ^[11]	Data retention current	$V_{CC} = V_{DR}$, $\overline{CE}_1 \geq V_{CC} - 0.2 V$, $CE_2 \leq 0.2 V$, $V_{IN} \geq V_{CC} - 0.2 V$ or $V_{IN} \leq 0.2 V$	–	1	3	μA
t_{CDR} ^[9]	Chip deselect to data retention time		0	–	–	ns
t_R ^[12]	Operation recovery time		55	–	–	ns

Data Retention Waveform^[13]

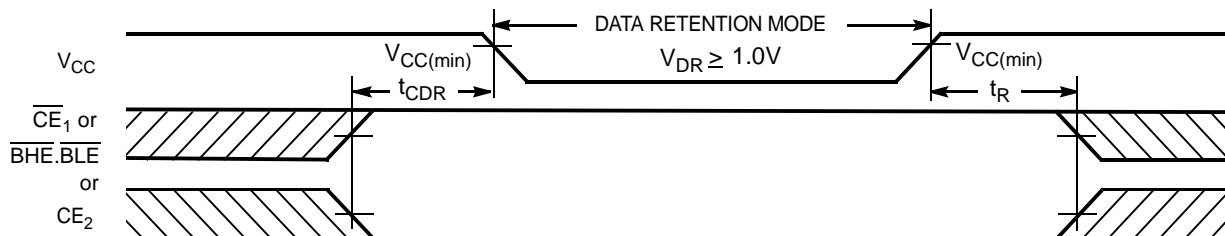

Notes

9. Tested initially and after any design or process changes that may affect these parameters.
10. Typical values are included for reference only and are not guaranteed or tested. Typical values are measured at $V_{CC} = V_{CC(typ)}$, $T_A = 25^\circ C$.
11. Chip enable (CE) and byte enables (BHE and BLE) need to be tied to CMOS levels to meet the $I_{SB1}/I_{SB2}/I_{CCDR}$ spec. Other inputs can be left floating.
12. Full device operation requires linear V_{CC} ramp from V_{DR} to $V_{CC(min)} \geq 100 \mu s$ or stable at $V_{CC(min)} \geq 100 \mu s$.
13. BHE.BLE is the AND of both BHE and BLE. Deselect the chip by either disabling chip enable signals or by disabling both \overline{BHE} and \overline{BLE} .

Switching Characteristics (Over the Operating Range)

Parameter ^[14, 15]	Description	55 ns		Unit
		Min	Max	
Read Cycle				
t_{RC}	Read cycle time	55	–	ns
t_{AA}	Address to data valid	–	55	ns
t_{OHA}	Data hold from address change	10	–	ns
t_{ACE}	\overline{CE}_1 LOW and CE_2 HIGH to data valid	–	55	ns
t_{DOE}	\overline{OE} LOW to data valid	–	25	ns
t_{LZOE}	\overline{OE} LOW to Low-Z ^[16]	5	–	ns
t_{HZOE}	\overline{OE} HIGH to High-Z ^[16, 17]	–	18	ns
t_{LZCE}	\overline{CE}_1 LOW and CE_2 HIGH to Low-Z ^[16]	10	–	ns
t_{HZCE}	\overline{CE}_1 HIGH and CE_2 LOW to High-Z ^[16, 17]	–	18	ns
t_{PU}	\overline{CE}_1 LOW and CE_2 HIGH to power up	0	–	ns
t_{PD}	\overline{CE}_1 HIGH and CE_2 LOW to power down	–	55	ns
t_{DBE}	$\overline{BLE}/\overline{BHE}$ LOW to data valid	–	55	ns
t_{LZBE} ^[18]	$\overline{BLE}/\overline{BHE}$ LOW to Low-Z ^[16]	10	–	ns
t_{HZBE}	$\overline{BLE}/\overline{BHE}$ HIGH to High-Z ^[16, 17]	–	18	ns
Write Cycle ^[19]				
t_{WC}	Write cycle time	45	–	ns
t_{SCE}	\overline{CE}_1 LOW and CE_2 HIGH to write end	35	–	ns
t_{AW}	Address setup to write end	35	–	ns
t_{HA}	Address hold from write end	0	–	ns
t_{SA}	Address setup to write start	0	–	ns
t_{PWE}	\overline{WE} pulse width	35	–	ns
t_{BW}	$\overline{BLE}/\overline{BHE}$ LOW to write end	35	–	ns
t_{SD}	Data setup to write end	25	–	ns
t_{HD}	Data hold from write end	0	–	ns
t_{HZWE}	\overline{WE} LOW to High-Z ^[16, 17]	–	18	ns
t_{LZWE}	\overline{WE} HIGH to Low-Z ^[16]	10	–	ns

Notes

14. Test conditions for all parameters other than tri-state parameters assume signal transition time of 1V/ns or less, timing reference levels of $V_{CC(typ)}/2$, input pulse levels of 0 to $V_{CC(typ)}$, and output loading of the specified I_{OL}/I_{OH} as shown in the "AC Test Loads and Waveforms" on page 6.
15. AC timing parameters are subject to byte enable signals (BHE or BLE) not switching when chip is disabled. Please see application note AN13842 for further clarification.
16. At any given temperature and voltage condition, t_{HZCE} is less than t_{LZCE} , t_{HZBE} is less than t_{LZBE} , t_{HZOE} is less than t_{LZOE} , and t_{HZWE} is less than t_{LZWE} for any given device.
17. t_{HZOE} , t_{HZCE} , t_{HZBE} , and t_{HZWE} transitions are measured when the output enters a high impedance state.
18. If both byte enables are toggled together, this value is 10 ns.
19. The internal write time of the memory is defined by the overlap of \overline{WE} , $\overline{CE} = V_{IL}$, \overline{BHE} and/or $\overline{BLE} = V_{IL}$, and $CE_2 = V_{IH}$. All signals must be ACTIVE to initiate a write and any of these signals can terminate a write by going INACTIVE. The data input setup and hold timing must be referenced to the edge of the signal that terminates the write.

Switching Waveforms

Figure 1. Read Cycle 1 (Address Transition Controlled) [20, 21]

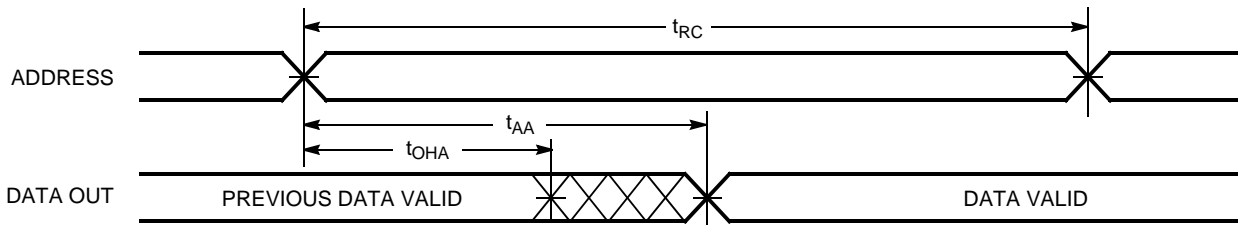
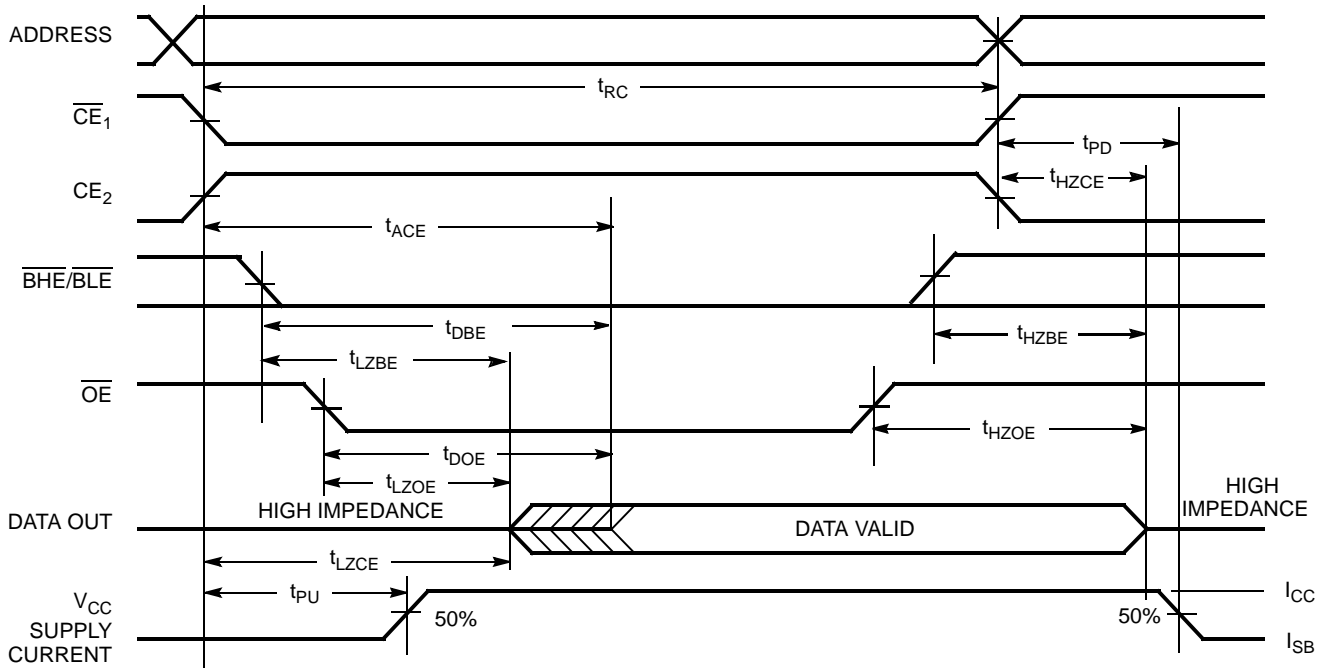

Figure 2. Read Cycle 2 (\overline{OE} Controlled) [21, 22]



Notes:

- 20. The device is continuously selected. \overline{OE} , $\overline{CE}_1 = V_{IL}$, \overline{BHE} and/or $\overline{BLE} = V_{IL}$, and $CE_2 = V_{IH}$.
- 21. \overline{WE} is HIGH for read cycle.
- 22. Address valid before or similar to \overline{CE}_1 , \overline{BHE} , \overline{BLE} transition LOW and CE_2 transition HIGH.

Switching Waveforms (continued)

Figure 3. Write Cycle 1 (\overline{WE} Controlled) [23, 24, 25]

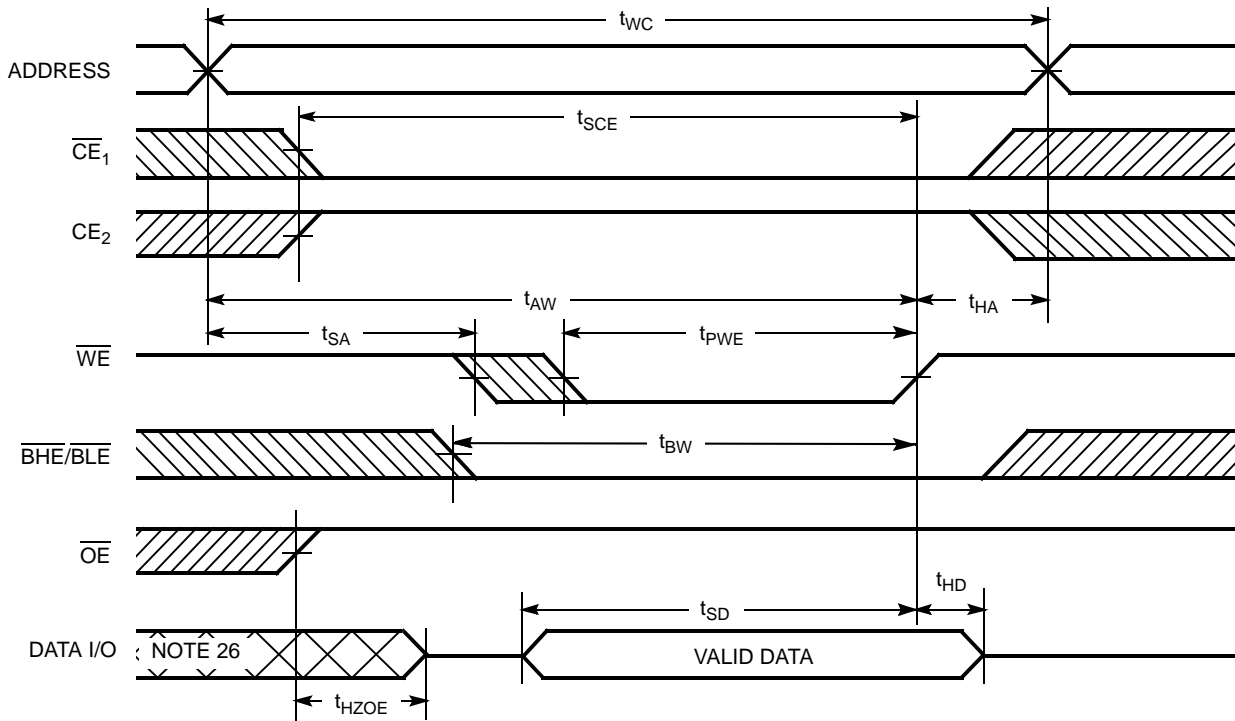
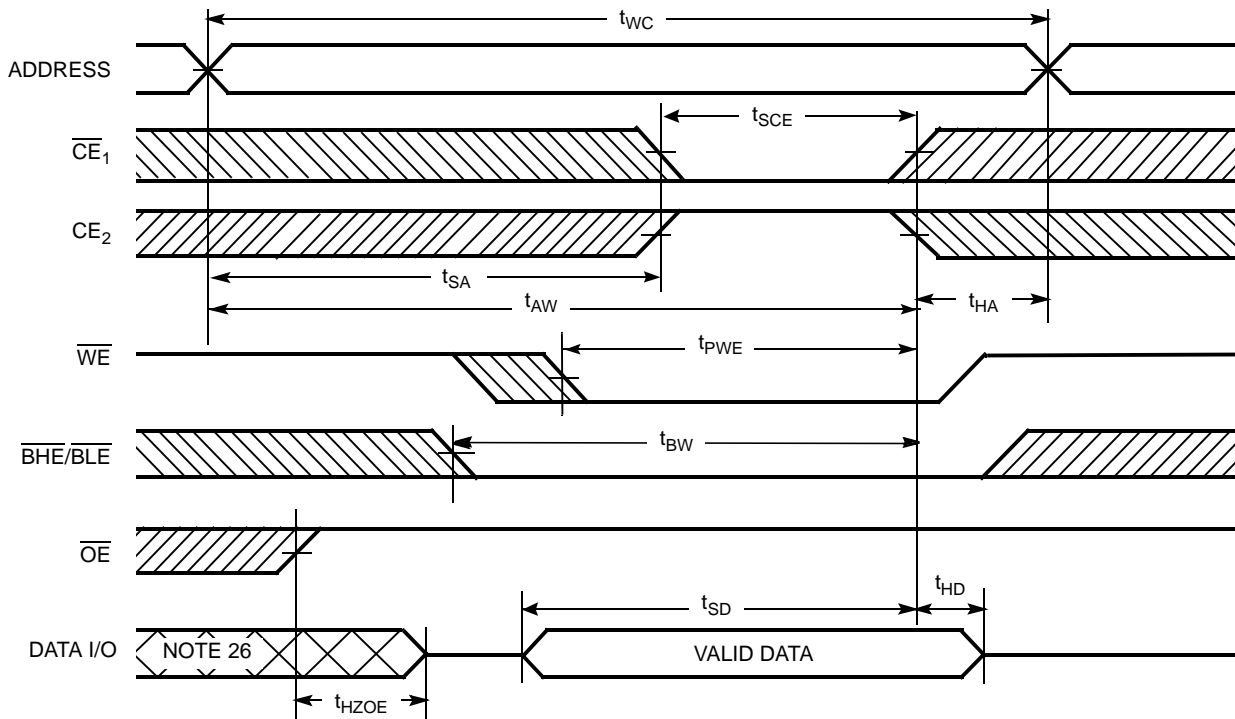

Figure 4. Write Cycle 2 (\overline{CE}_1 or CE_2 Controlled) [23, 24, 25]



Notes

- 23. The internal write time of the memory is defined by the overlap of \overline{WE} , $\overline{CE}_1 = V_{IL}$, \overline{BHE} and/or $\overline{BLE} = V_{IL}$, and $CE_2 = V_{IH}$. All signals must be ACTIVE to initiate a write and any of these signals can terminate a write by going INACTIVE. The data input setup and hold timing must be referenced to the edge of the signal that terminates the write.
- 24. Data I/O is high impedance if $\overline{OE} = V_{IH}$.
- 25. If \overline{CE}_1 goes HIGH and CE_2 goes LOW simultaneously with $\overline{WE} = V_{IH}$, the output remains in a high impedance state.
- 26. During this period, the I/Os are in output state and input signals must not be applied.

Switching Waveforms (continued)

Figure 5. Write Cycle 3 (\overline{WE} Controlled, \overline{OE} LOW) [27]

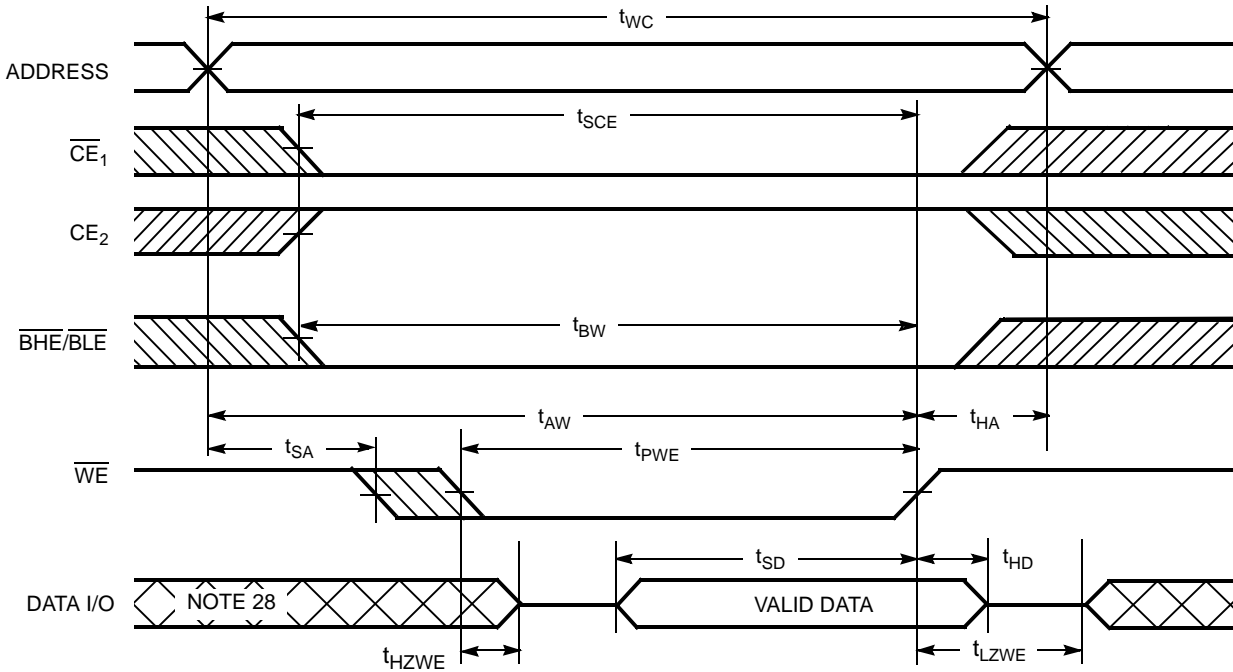
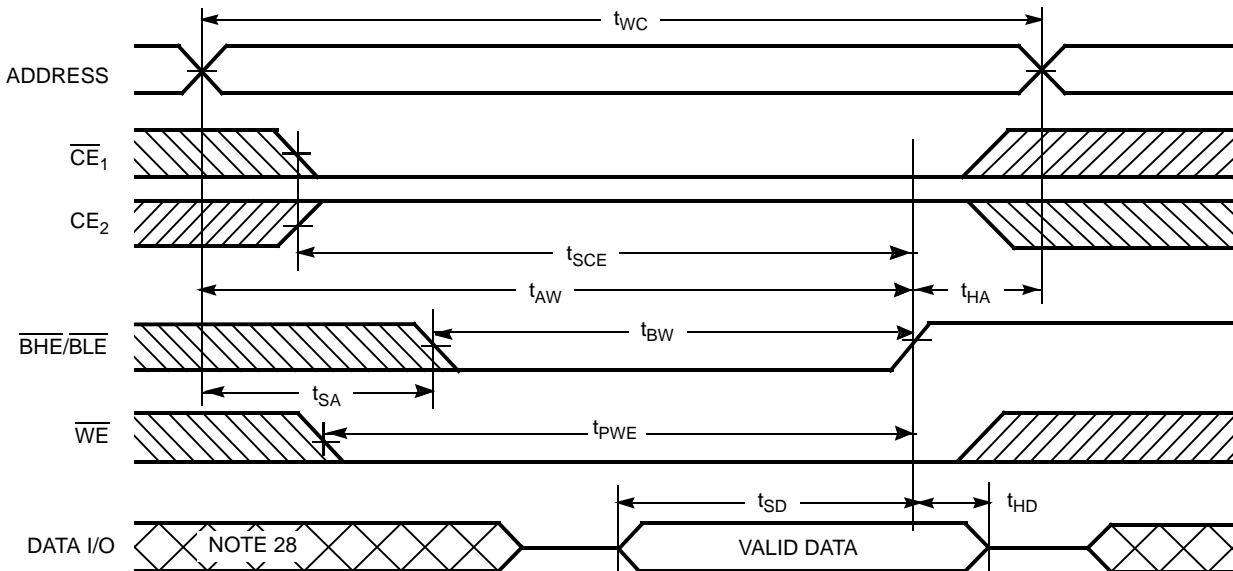

Figure 6. Write Cycle 4 ($\overline{BHE}/\overline{BLE}$ Controlled, \overline{OE} LOW) [27]



Notes

- 27. If \overline{CE}_1 goes HIGH and CE_2 goes LOW simultaneously with $\overline{WE} = V_{IH}$, the output remains in a high impedance state.
- 28. During this period, the I/Os are in output state and input signals must not be applied.

Truth Table

\overline{CE}_1	\overline{CE}_2	\overline{WE}	\overline{OE}	\overline{BHE}	\overline{BLE}	Inputs/Outputs	Mode	Power
H	$\chi^{[29]}$	X	X	$\chi^{[29]}$	$\chi^{[29]}$	High-Z	Deselect/Power down	Standby (I_{SB})
$\chi^{[29]}$	L	X	X	$\chi^{[29]}$	$\chi^{[29]}$	High-Z	Deselect/Power down	Standby (I_{SB})
$\chi^{[29]}$	$\chi^{[29]}$	X	X	H	H	High-Z	Deselect/Power down	Standby (I_{SB})
L	H	H	L	L	L	Data out (I/O_0 – I/O_{15})	Read	Active (I_{CC})
L	H	H	L	H	L	Data out (I/O_0 – I/O_7); High-Z (I/O_8 – I/O_{15})	Read	Active (I_{CC})
L	H	H	L	L	H	High-Z (I/O_0 – I/O_7); Data out (I/O_8 – I/O_{15})	Read	Active (I_{CC})
L	H	H	H	L	H	High-Z	Output disabled	Active (I_{CC})
L	H	H	H	H	L	High-Z	Output disabled	Active (I_{CC})
L	H	H	H	L	L	High-Z	Output disabled	Active (I_{CC})
L	H	L	X	L	L	Data in (I/O_0 – I/O_{15})	Write	Active (I_{CC})
L	H	L	X	H	L	Data in (I/O_0 – I/O_7); High-Z (I/O_8 – I/O_{15})	Write	Active (I_{CC})
L	H	L	X	L	H	High-Z (I/O_0 – I/O_7); Data in (I/O_8 – I/O_{15})	Write	Active (I_{CC})

Note

29. The 'X' (Don't care) state for the Chip enables and Byte enables in the truth table refer to the logic state (either HIGH or LOW). Intermediate voltage levels on these pins is not permitted.

Ordering Information

Speed (ns)	Ordering Code	Package Diagram	Package Type	Operating Range
55	CY62157EV18LL-55BVXI	51-85150	48-ball Very Fine Pitch Ball Grid Array (Pb-free)	Industrial

Contact your local Cypress sales representative for availability of these parts.

Ordering Code Definitions

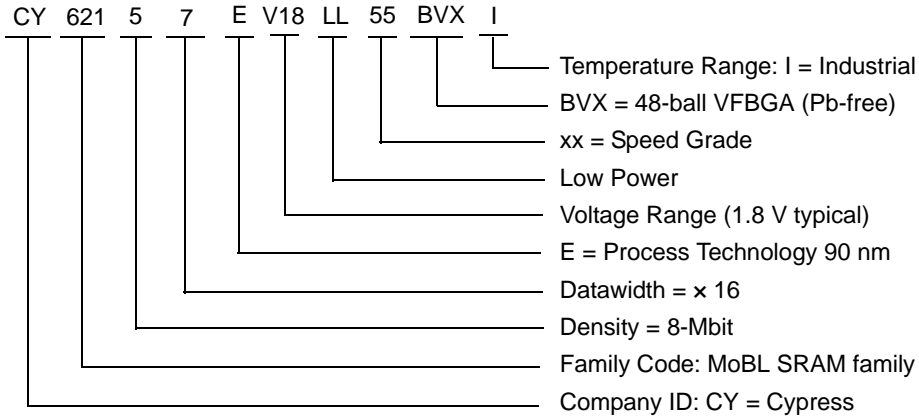

Acronyms

Acronym	Description
BHE	byte high enable
BLE	byte low enable
CE	chip enable
CMOS	complementary metal oxide semiconductor
I/O	input/output
OE	output enable
SRAM	static random access memory
VFBGA	very fine ball grid array
WE	write enable

Document Conventions

Units of Measure

Symbol	Unit of Measure
°C	degrees Celsius
μA	microamperes
mA	milliamperes
MHz	megahertz
ns	nanoseconds
pF	picofarads
V	volts
Ω	ohms
W	watts

Document History

Document Title: CY62157EV18 MoBL [®] , 8-Mbit (512K x 16) Static RAM				
Document Number: 38-05490				
Rev.	ECN No.	Issue Date	Orig. of Change	Description of Change
**	202862	See ECN	AJU	New Data Sheet
*A	291272	See ECN	SYT	Converted from Advance Information to Preliminary Changed V _{CC} Max from 2.20 to 2.25 V Changed V _{CC} stabilization time in footnote #7 from 100 μs to 200 μs Changed I _{CCDR} from 4 to 4.5 μA Changed t _{OHA} from 6 ns to 10 ns for both 35 ns and 45 ns Speed Bins Changed t _{DOE} from 15 and 22 ns to 18 and 22 ns for the 35 and 45 ns Speed Bins respectively Changed t _{HZOE} , t _{HZBE} and t _{HZWE} from 12 and 15 ns to 15 and 18 ns for the 35 and 45 ns Speed Bins respectively Changed t _{HZCE} from 12 and 15 ns to 18 and 22 ns for the 35 and 45 ns Speed Bins respectively Changed t _{SCE} , t _{AW} , and t _{BW} from 25 and 40 ns to 30 and 35 ns for the 35 and 45 ns Speed Bins respectively Changed t _{SD} from 15 and 20 ns to 18 and 22 ns for the 35 and 45 ns Speed Bins respectively Added Pb-Free Package Information
*B	444306	See ECN	NXR	Converted from Preliminary to Final Removed 35 ns speed bin and "L" bin Changed ball E3 from DNU to NC Removed redundant footnote on DNU Modified Maximum Ratings spec for Supply Voltage and DC Input Voltage from 2.4V to 2.45V Changed the I _{CC} Typ value from 16 mA to 18 mA and I _{CC} Max value from 28 mA to 25 mA for test condition f = fax = 1/t _{RC} Changed the I _{CC} Max value from 2.3 mA to 3 mA for test condition f = 1MHz Changed the I _{SB1} and I _{SB2} Max value from 4.5 μA to 8 μA and Typ value from 0.9 μA to 2 μA respectively Updated Thermal Resistance table Changed Test Load Capacitance from 50 pF to 30 pF Added Typ value for I _{CCDR} Changed the I _{CCDR} Max value from 4.5 μA to 3 μA Corrected t _R in Data Retention Characteristics from 100 μs to t _{RC} ns Changed t _{LZOE} from 3 to 5, changed t _{LZCE} from 6 to 10, changed t _{HZCE} from 22 to 18, changed t _{LZBE} from 6 to 5, changed t _{PWE} from 30 to 35, changed t _{SD} from 22 to 25, and changed t _{LZWE} from 6 to 10 Added footnote #13 Updated the ordering Information and replaced the Package Name column with Package Diagram
*C	571786	See ECN	VKN	Replaced 45ns speed bin with 55ns
*D	908120	See ECN	VKN	Added footnote #7 related to I _{SB2} Added footnote #12 related AC timing parameters
*E	2934396	06/03/10	VKN	Added footnote #23 related to chip enable Updated package diagram and template
*F	3110053	12/14/2010	PRAS	Changed Table Footnotes to Footnotes. Added Ordering Code Definitions.
*G	3243545	04/28/2011	RAME	Updated as per template. Added Acronyms and Units of Measure table.
*H	3295175	06/29/2011	RAME	Added I _{SB1} and I _{CCDR} to footnotes 7 and 11. Modified footnote 29 and referenced in Truth Table .

Sales, Solutions, and Legal Information

Worldwide Sales and Design Support

Cypress maintains a worldwide network of offices, solution centers, manufacturer's representatives, and distributors. To find the office closest to you, visit us at [Cypress Locations](#).

Products

Automotive	cypress.com/go/automotive
Clocks & Buffers	cypress.com/go/clocks
Interface	cypress.com/go/interface
Lighting & Power Control	cypress.com/go/powerpsoc cypress.com/go/plc
Memory	cypress.com/go/memory
Optical & Image Sensing	cypress.com/go/image
PSoC	cypress.com/go/psoc
Touch Sensing	cypress.com/go/touch
USB Controllers	cypress.com/go/USB
Wireless/RF	cypress.com/go/wireless

PSoC Solutions

psoc.cypress.com/solutions
PSoC 1 | PSoC 3 | PSoC 5

© Cypress Semiconductor Corporation, 2004-2011. The information contained herein is subject to change without notice. Cypress Semiconductor Corporation assumes no responsibility for the use of any circuitry other than circuitry embodied in a Cypress product. Nor does it convey or imply any license under patent or other rights. Cypress products are not warranted nor intended to be used for medical, life support, life saving, critical control or safety applications, unless pursuant to an express written agreement with Cypress. Furthermore, Cypress does not authorize its products for use as critical components in life-support systems where a malfunction or failure may reasonably be expected to result in significant injury to the user. The inclusion of Cypress products in life-support systems application implies that the manufacturer assumes all risk of such use and in doing so indemnifies Cypress against all charges.

Any Source Code (software and/or firmware) is owned by Cypress Semiconductor Corporation (Cypress) and is protected by and subject to worldwide patent protection (United States and foreign), United States copyright laws and international treaty provisions. Cypress hereby grants to licensee a personal, non-exclusive, non-transferable license to copy, use, modify, create derivative works of, and compile the Cypress Source Code and derivative works for the sole purpose of creating custom software and or firmware in support of licensee product to be used only in conjunction with a Cypress integrated circuit as specified in the applicable agreement. Any reproduction, modification, translation, compilation, or representation of this Source Code except as specified above is prohibited without the express written permission of Cypress.

Disclaimer: CYPRESS MAKES NO WARRANTY OF ANY KIND, EXPRESS OR IMPLIED, WITH REGARD TO THIS MATERIAL, INCLUDING, BUT NOT LIMITED TO, THE IMPLIED WARRANTIES OF MERCHANTABILITY AND FITNESS FOR A PARTICULAR PURPOSE. Cypress reserves the right to make changes without further notice to the materials described herein. Cypress does not assume any liability arising out of the application or use of any product or circuit described herein. Cypress does not authorize its products for use as critical components in life-support systems where a malfunction or failure may reasonably be expected to result in significant injury to the user. The inclusion of Cypress' product in a life-support systems application implies that the manufacturer assumes all risk of such use and in doing so indemnifies Cypress against all charges.

Use may be limited by and subject to the applicable Cypress software license agreement.