

Features

- Temperature Ranges
 - Industrial: -40 °C to 85 °C
 - Commercial: 0 °C to 70 °C
 - Automotive-A: -40 °C to 85 °C
- Single 3.3 V power supply
- Ideal for low-voltage cache memory applications
- High speed: 12 ns
- Low active power
 - 180 mW (max)
- Low-power alpha immune 6T cell
- Available in pb-free and non pb-free plastic SOJ and TSOP-I packages

Functional Description

The CY7C1399BN is a high-performance 3.3 V CMOS Static RAM organized as 32,768 words by 8 bits. Easy memory expansion is provided by an active LOW Chip Enable (\overline{CE}) and active LOW Output Enable (\overline{OE}) and tristate drivers. The device has an automatic power-down feature, reducing the power consumption by more than 95% when deselected.

An active LOW Write Enable signal (\overline{WE}) controls the writing/reading operation of the memory. When \overline{CE} and \overline{WE} inputs are both LOW, data on the eight data input/output pins (I/O_0 through I/O_7) is written into the memory location addressed by the address present on the address pins (A_0 through A_{14}). Reading the device is accomplished by selecting the device and enabling the outputs, \overline{CE} and \overline{OE} active LOW, while \overline{WE} remains inactive or HIGH. Under these conditions, the contents of the location addressed by the information on address pins is present on the eight data input/output pins.

The input/output pins remain in a high-impedance state unless the chip is selected, outputs are enabled, and Write Enable (\overline{WE}) is HIGH. The CY7C1399BN is available in 28-pin standard 300-mil-wide SOJ and TSOP Type I packages.

Logic Block Diagram

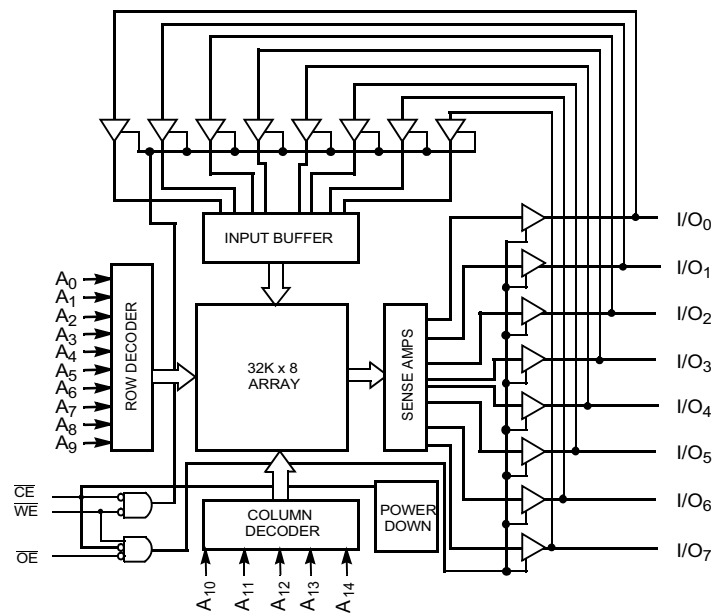

Selection Guide

Description		-12	-15
Maximum access time (ns)		12	15
Maximum operating current (mA)		55	50
Maximum CMOS standby current (µA)	Commercial	500	–
	Commercial (L)	50	–
	Industrial	500	500
	Automotive-A	–	500

Pin Configuration

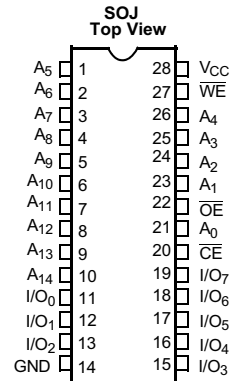
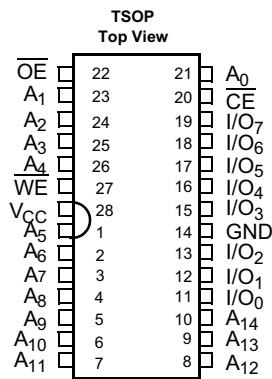

Maximum Ratings

Exceeding maximum ratings may shorten the useful life of the device. User guidelines are not tested.

Storage temperature -65 °C to +150 °C

Ambient temperature with power applied -55 °C to +125 °C

Supply voltage on V_{CC} to relative GND^[1] -0.5 V to +4.6 V

DC voltage applied to outputs in high Z State^[1] -0.5 V to $V_{CC} + 0.5 V$

DC input voltage^[1] -0.5 V to $V_{CC} + 0.5 V$

Output current into outputs (LOW) 20 mA

Static discharge voltage..... >2001 V
(per MIL-STD-883, Method 3015)

Latch-up current >200 mA

Operating Range

Range	Ambient Temperature	V_{CC}
Commercial	0 °C to +70 °C	3.3 V ±300 mV
Industrial	-40 °C to +85 °C	
Automotive-A	-40 °C to +85 °C	

Electrical Characteristics

Over the Operating Range^[1]

Parameter	Description	Test Conditions	-12		-15		Unit	
			Min	Max	Min	Max		
V_{OH}	Output HIGH voltage	Min V_{CC} , $I_{OH} = -2.0 \text{ mA}$	2.4	-	2.4	-	V	
V_{OL}	Output LOW voltage	Min V_{CC} , $I_{OL} = 4.0 \text{ mA}$	-	0.4	-	0.4	V	
V_{IH}	Input HIGH voltage		2.2	$V_{CC} + 0.3 V$	2.2	$V_{CC} + 0.3 V$	V	
$V_{IL}^{[1]}$	Input LOW voltage		-0.3	0.8	-0.3	0.8	V	
I_{IX}	Input leakage current		-1	+1	-1	+1	μA	
I_{OZ}	Output leakage current	$GND \leq V_{IN} \leq V_{CC}$, Output disabled	-5	+5	-5	+5	μA	
I_{CC}	V_{CC} operating supply current	Max V_{CC} , $I_{OUT} = 0 \text{ mA}$, $f = f_{MAX} = 1/t_{RC}$	-	55	-	50	mA	
I_{SB1}	Automatic CE power-down current—TTL inputs	Max V_{CC} , $\overline{CE} \geq V_{IH}$, $V_{IN} \geq V_{IH}$, or $V_{IN} \leq V_{IL}$, $f = f_{MAX}$	Comm'l	-	5	-	-	mA
			Comm'l (L)	-	4	-	-	mA
			Ind'l	-	5	-	5	mA
			Auto-A	-	-	-	5	mA
I_{SB2}	Automatic CE Power-down current—CMOS inputs ^[2]	Max V_{CC} , $\overline{CE} \geq V_{CC} - 0.3 V$, $V_{IN} \geq V_{CC} - 0.3 V$, or $V_{IN} \leq 0.3 V$, $WE \geq V_{CC} - 0.3 V$ or $WE \leq 0.3 V$, $f = f_{MAX}$	Comm'l	-	500	-	-	μA
			Comm'l (L)	-	50	-	-	μA
			Ind'l	-	500	-	500	μA
			Auto-A	-	-	-	500	μA

Notes

1. Minimum voltage is equal to -2.0 V for pulse durations of less than 20 ns.
2. Device draws low standby current regardless of switching on the addresses.

Capacitance

Parameter ^[5]	Description	Test Conditions	Max	Unit
C _{IN} : Addresses	Input capacitance	T _A = 25 °C, f = 1 MHz, V _{CC} = 3.3 V	5	pF
C _{IN} : Controls			6	pF
C _{OUT}	Output capacitance		6	pF

AC Test Loads and Waveforms^[4]

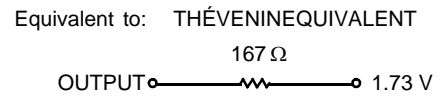
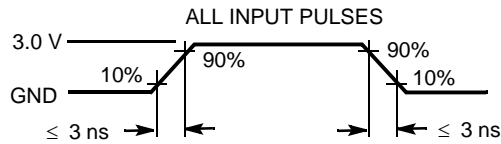
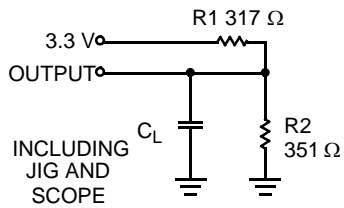

Notes

- 3. Tested initially and after any design or process changes that may affect these parameters.
- 4. Test conditions assume signal transition time of 3 ns or less, timing reference levels of 1.5 V, input pulse levels of 0 to 3.0 V, and output loading of the specified I_{OL}/I_{OH} and capacitance C_L = 30 pF.

Switching Characteristics

Over the Operating Range^[6]

Parameter	Description	-12		-15		Unit
		Min	Max	Min	Max	
Read Cycle						
t _{RC}	Read cycle time	12	–	15	–	ns
t _{AA}	Address to data valid	–	12	–	15	ns
t _{OHA}	Data hold from address change	3	–	3	–	ns
t _{ACE}	\overline{CE} LOW to data valid	–	12	–	15	ns
t _{DOE}	\overline{OE} LOW to data valid	–	5	–	6	ns
t _{LZOE}	\overline{OE} LOW to low Z ^[7]	0	–	0	–	ns
t _{HZOE}	\overline{OE} HIGH to high Z ^[7, 8]	–	5	–	6	ns
t _{LZCE}	\overline{CE} LOW to low Z ^[7]	3	–	3	–	ns
t _{HZCE}	\overline{CE} HIGH to high Z ^[7, 8]	–	6	–	7	ns
t _{PU}	\overline{CE} LOW to power-up	0	–	0	–	ns
t _{PD}	\overline{CE} HIGH to power-down	–	12	–	15	ns
Write Cycle^[9, 10]						
t _{WC}	Write cycle time	12	–	15	–	ns
t _{SCE}	\overline{CE} LOW to write end	8	–	10	–	ns
t _{AW}	Address setup to write end	8	–	10	–	ns
t _{HA}	Address hold from write end	0	–	0	–	ns
t _{SA}	Address setup to write start	0	–	0	–	ns
t _{PWE}	\overline{WE} pulse width	8	–	10	–	ns
t _{SD}	Data setup to write end	7	–	8	–	ns
t _{HD}	Data hold from write end	0	–	0	–	ns
t _{HZWE}	\overline{WE} low to high Z ^[9]	–	7	–	7	ns
t _{LZWE}	\overline{WE} high to low Z ^[7]	3	–	3	–	ns

Notes

5. Tested initially and after any design or process changes that may affect these parameters.
6. Test conditions assume signal transition time of 3 ns or less, timing reference levels of 1.5 V, input pulse levels of 0 to 3.0 V, and output loading of the specified I_{OL}/I_{OH} and capacitance C_L = 30 pF.
7. At any given temperature and voltage condition, t_{HZCE} is less than t_{LZCE}, t_{HZOE} is less than t_{LZOE}, and t_{HZWE} is less than t_{LZWE} for any given device.
8. t_{HZOE}, t_{HZCE}, t_{HZWE} are specified with C_L = 5 pF as in AC Test Loads. Transition is measured ±500 mV from steady state voltage.
9. The internal write time of the memory is defined by the overlap of \overline{CE} LOW and \overline{WE} LOW. Both signals must be LOW to initiate a write and either signal can terminate a write by going HIGH. The data input set-up and hold timing should be referenced to the rising edge of the signal that terminates the write.
10. The minimum write cycle time for write cycle #3 (\overline{WE} controlled, \overline{OE} LOW) is the sum of t_{HZWE} and t_{SD}.

Data Retention Characteristics (Over the Operating Range - L version only)

Parameter	Description	Conditions	Min	Max	Unit
V_{DR}	V_{CC} for data retention		2.0	–	V
I_{CCDR}	Data retention current	$V_{CC} = V_{DR} = 2.0\text{ V}$, $CE \geq V_{CC} - 0.3\text{ V}$,	0	20	μA
t_{CDR}	Chip deselect to data retention time	$V_{IN} \geq V_{CC} - 0.3\text{ V}$ or $V_{IN} \leq 0.3\text{ V}$	0	–	ns
t_R	Operation recovery time		t_{RC}	–	ns

Data Retention Waveform

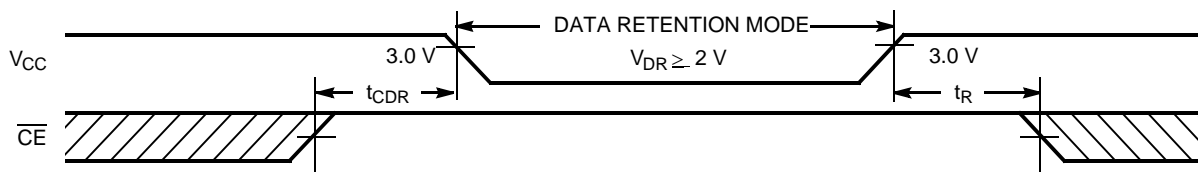

Switching Waveforms

Figure 1. Read Cycle No. 1^[11, 12]

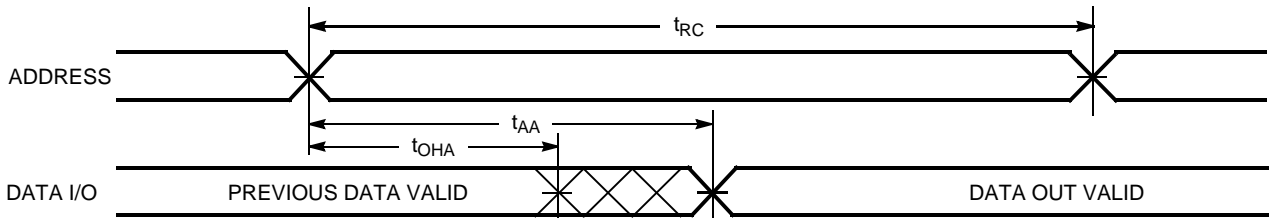
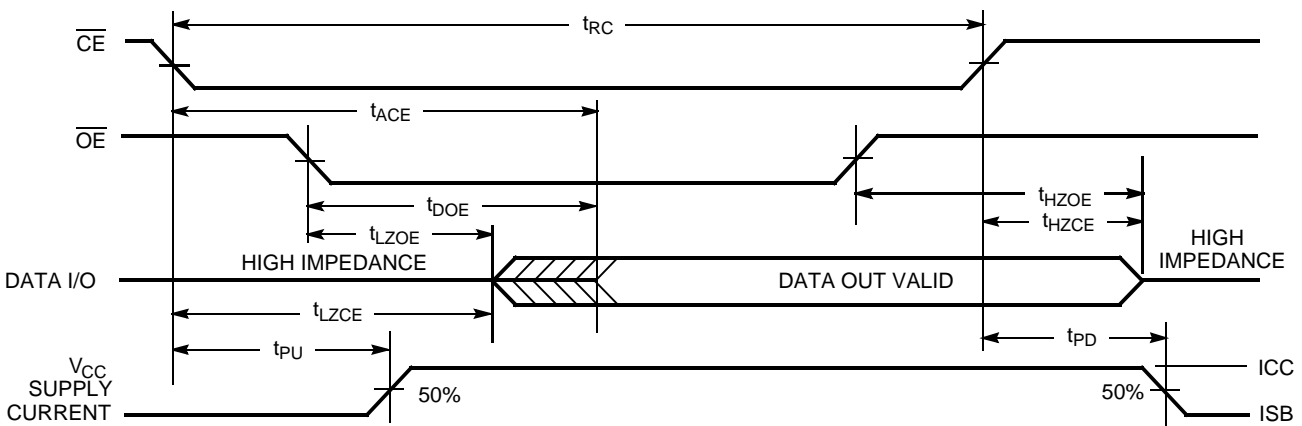

Figure 2. Read Cycle No. 2^[12, 13]



Notes

- 11. Device is continuously selected. \overline{OE} , $\overline{CE} = V_{IL}$.
- 12. \overline{WE} is HIGH for read cycle.
- 13. Address valid prior to or coincident with \overline{CE} transition LOW.

Switching Waveforms (continued)

Figure 3. Write Cycle No. 1 (\overline{WE} Controlled)^[9, 14, 15]

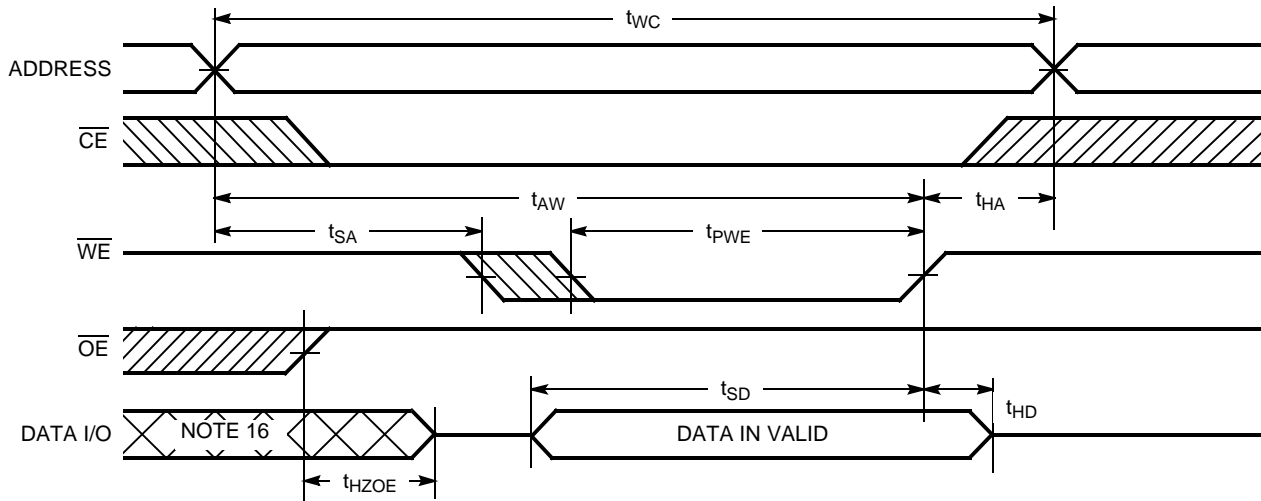

Figure 4. Write Cycle No. 2 (\overline{CE} Controlled)^[9, 14, 15]

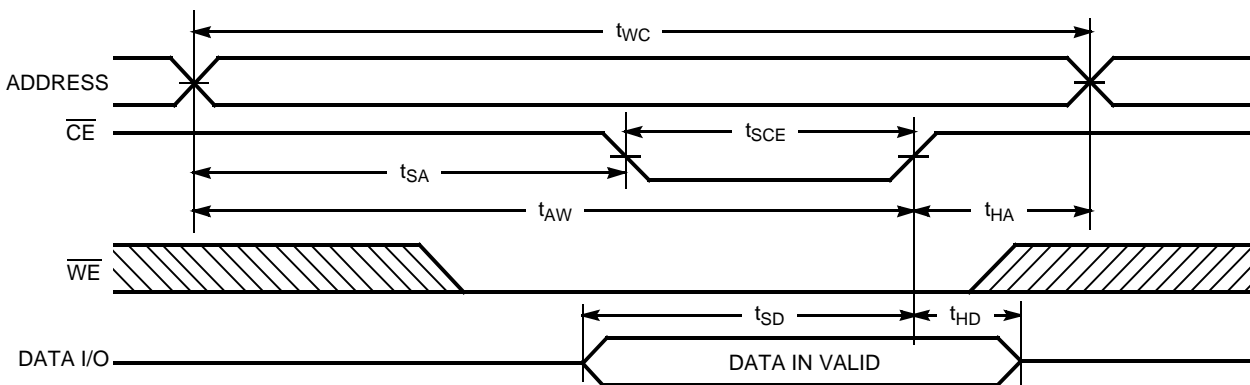
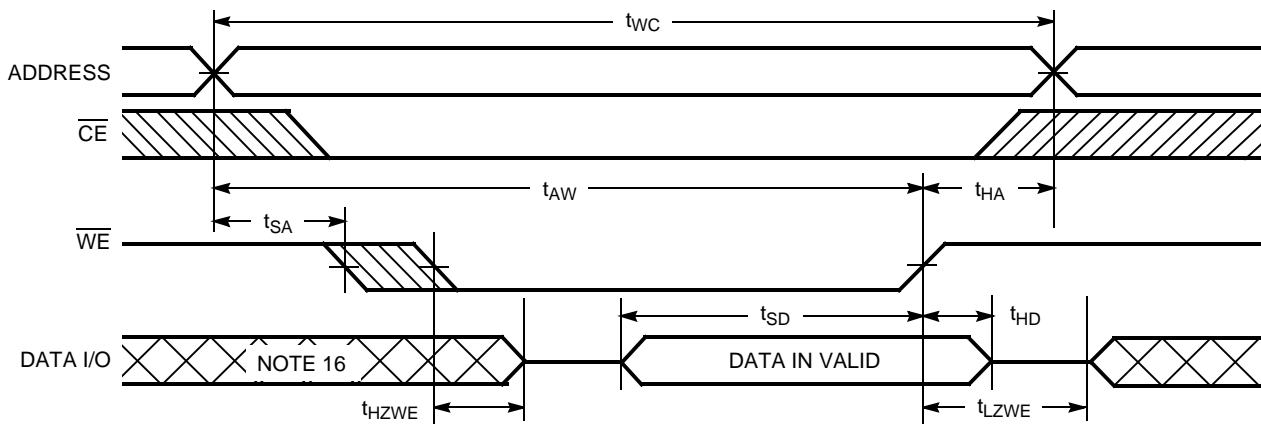

Figure 5. Write Cycle No. 3 (\overline{WE} Controlled, \overline{OE} LOW)^[10, 15]



Notes

- 14. Data I/O is high impedance if $\overline{OE} = V_{IH}$.
- 15. If \overline{CE} goes HIGH simultaneously with \overline{WE} HIGH, the output remains in a high-impedance state.
- 16. During this period, the I/Os are in the output state and input signals should not be applied.

Truth Table

\overline{CE}	\overline{WE}	\overline{OE}	Input/Output	Mode	Power
H	X	X	High Z	Deselect/Power-down	Standby (I_{SB})
L	H	L	Data Out	Read	Active (I_{CC})
L	L	X	Data In	Write	Active (I_{CC})
L	H	H	High Z	Deselect, Output disabled	Active (I_{CC})

Ordering Information

Cypress offers other versions of this type of product in many different configurations and features. The following table contains only the list of parts that are currently available.

For a complete listing of all options, visit the Cypress website at www.cypress.com and refer to the product summary page at <http://www.cypress.com/products> or contact your local sales representative.

Cypress maintains a worldwide network of offices, solution centers, manufacturer's representatives and distributors. To find the office closest to you, visit us at <http://www.cypress.com/go/datasheet/offices>.

Speed (ns)	Ordering Code	Package Diagram	Package Type	Operating Range
12	CY7C1399BN-12VXC	51-85031	28-pin molded SOJ (Pb-free)	Commercial
	CY7C1399BN-12ZXC	51-85071	28-pin TSOP I (Pb-free)	
	CY7C1399BNL-12ZXC		28-pin TSOP I (Pb-free)	
	CY7C1399BN-12VXI	51-85031	28-pin molded SOJ (Pb-free)	Industrial
15	CY7C1399BN-15ZXI	51-85071	28-pin TSOP I (Pb-free)	Industrial
	CY7C1399BN-15VXA	51-85031	28-pin molded SOJ (Pb-free)	Automotive-A

Contact your local sales representative regarding availability of these parts.

Ordering Code Definitions

CY 7 C 1 399 BN L - ## X V C

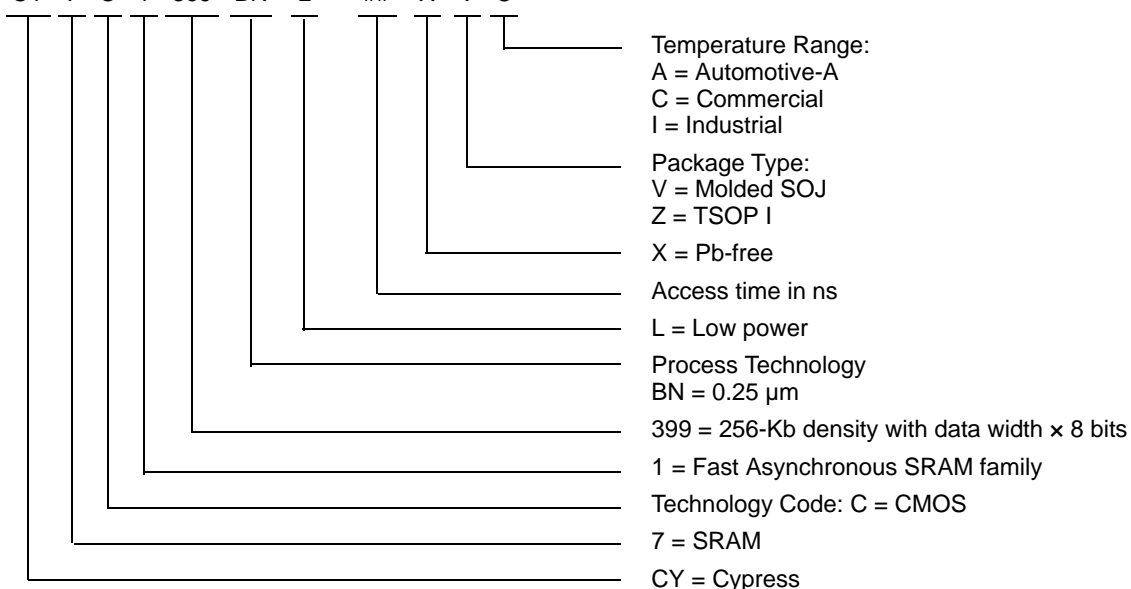

Package Diagrams

Figure 6. 28-pin (300-Mil) Molded SOJ (51-85031)

NOTE :

1. JEDEC STD REF M0088
2. BODY LENGTH DIMENSION DOES NOT INCLUDE MOLD PROTRUSION/END FLASH
MOLD PROTRUSION/END FLASH SHALL NOT EXCEED 0.006 in (0.152 mm) PER SIDE
3. DIMENSIONS IN INCHES MIN.
MAX.

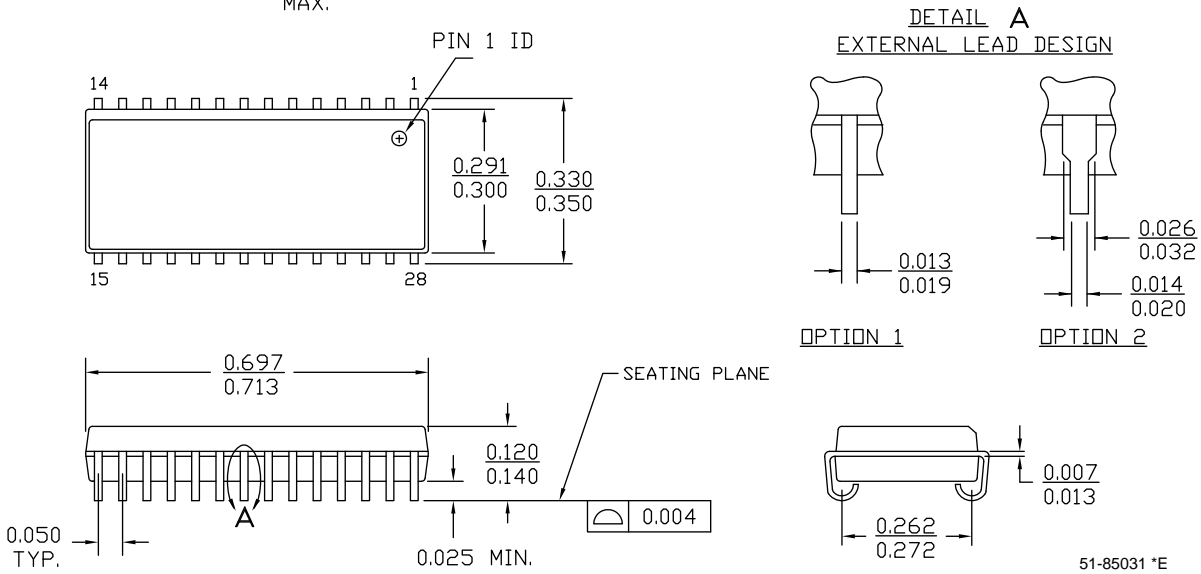
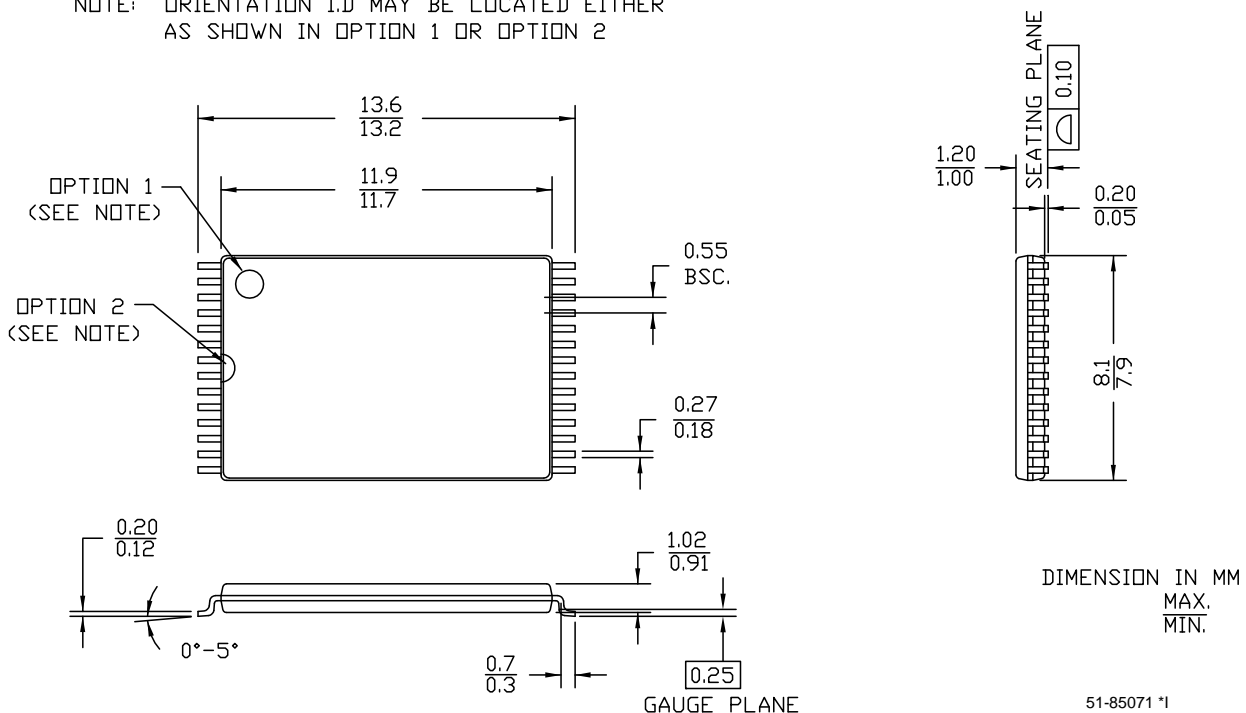

Figure 7. 28-pin TSOP 1 (8 x 13.4 mm) (51-85071)

NOTE: ORIENTATION I.D MAY BE LOCATED EITHER AS SHOWN IN OPTION 1 OR OPTION 2



Acronyms

Acronym	Description
BHE	byte high enable
BLE	byte low enable
CE	chip enable
CMOS	complementary metal oxide semiconductor
I/O	input/output
OE	output enable
SRAM	static random access memory
TSOP	thin small outline package
WE	write enable

Document Conventions

Units of Measure

Symbol	Unit of Measure
ns	nanosecond
V	volt
μ A	microampere
mA	milliampere
mV	millivolt
mW	milliwatt
MHz	megahertz
pF	picofarad
°C	degree Celsius
W	watt

Document History Page

Document Title: CY7C1399BN 256 K (32 K x 8) Static RAM Document Number: 001-06490				
Revision	ECN	Orig. of Change	Submission Date	Description of Change
**	423877	NXR	See ECN	New Data Sheet
*A	498575	NXR	See ECN	Added Automotive-A range Removed I _{OS} parameter from DC Electrical Characteristics table Updated Ordering Information table.
*B	2896382	AJU	03/19/2010	Removed obsolete part numbers from Ordering Information table and updated package diagrams.
*C	3053362	PRAS	10/08/2010	Removed pruned part numbers CY7C1399BNL-15VXC and CY7C1399BNL-15VXCT. Added Ordering Code Definitions.
*D	3383869	TAVA	09/26/2011	Added Commercial temperature range under Features section on page 1. Removed reference to AN1064-SRAM System Design Guidelines on page 1. Modified the notes in figures under Read cycle and Write cycle sections. Updated template according to current Cypress standards. Rearranged sections for better clarity. Revised package diagrams. Added Acronyms and Units of measure.

Sales, Solutions, and Legal Information

Worldwide Sales and Design Support

Cypress maintains a worldwide network of offices, solution centers, manufacturer's representatives, and distributors. To find the office closest to you, visit us at [Cypress Locations](#).

Products

Automotive	cypress.com/go/automotive
Clocks & Buffers	cypress.com/go/clocks
Interface	cypress.com/go/interface
Lighting & Power Control	cypress.com/go/powerpsoc cypress.com/go/plc
Memory	cypress.com/go/memory
Optical & Image Sensing	cypress.com/go/image
PSoC	cypress.com/go/psoc
Touch Sensing	cypress.com/go/touch
USB Controllers	cypress.com/go/USB
Wireless/RF	cypress.com/go/wireless

PSoC Solutions

psoc.cypress.com/solutions
PSoC 1 | PSoC 3 | PSoC 5

© Cypress Semiconductor Corporation, 2006-2011. The information contained herein is subject to change without notice. Cypress Semiconductor Corporation assumes no responsibility for the use of any circuitry other than circuitry embodied in a Cypress product. Nor does it convey or imply any license under patent or other rights. Cypress products are not warranted nor intended to be used for medical, life support, life saving, critical control or safety applications, unless pursuant to an express written agreement with Cypress. Furthermore, Cypress does not authorize its products for use as critical components in life-support systems where a malfunction or failure may reasonably be expected to result in significant injury to the user. The inclusion of Cypress products in life-support systems application implies that the manufacturer assumes all risk of such use and in doing so indemnifies Cypress against all charges.

Any Source Code (software and/or firmware) is owned by Cypress Semiconductor Corporation (Cypress) and is protected by and subject to worldwide patent protection (United States and foreign), United States copyright laws and international treaty provisions. Cypress hereby grants to licensee a personal, non-exclusive, non-transferable license to copy, use, modify, create derivative works of, and compile the Cypress Source Code and derivative works for the sole purpose of creating custom software and or firmware in support of licensee product to be used only in conjunction with a Cypress integrated circuit as specified in the applicable agreement. Any reproduction, modification, translation, compilation, or representation of this Source Code except as specified above is prohibited without the express written permission of Cypress.

Disclaimer: CYPRESS MAKES NO WARRANTY OF ANY KIND, EXPRESS OR IMPLIED, WITH REGARD TO THIS MATERIAL, INCLUDING, BUT NOT LIMITED TO, THE IMPLIED WARRANTIES OF MERCHANTABILITY AND FITNESS FOR A PARTICULAR PURPOSE. Cypress reserves the right to make changes without further notice to the materials described herein. Cypress does not assume any liability arising out of the application or use of any product or circuit described herein. Cypress does not authorize its products for use as critical components in life-support systems where a malfunction or failure may reasonably be expected to result in significant injury to the user. The inclusion of Cypress' product in a life-support systems application implies that the manufacturer assumes all risk of such use and in doing so indemnifies Cypress against all charges.

Use may be limited by and subject to the applicable Cypress software license agreement.