

## Features

- Very high speed: 55 ns
- Wide voltage range: 2.20 V–3.60 V
- Ultra-low active power
  - Typical active current: 2 mA at  $f = 1$  MHz
  - Typical active current: 15 mA at  $f = f_{\max}$
- Ultra low standby power
- Easy memory expansion with  $\overline{CE}_1$ ,  $CE_2$  and  $\overline{OE}$  features
- Automatic power-down when deselected
- Complementary metal oxide semiconductor (CMOS) for optimum speed/power
- Packages offered in a 48-ball fine ball grid array (FBGA)

## Functional Description

The CY62177DV30 is a high-performance CMOS static RAM organized as 2M words by 16 bits. This device features advanced circuit design to provide ultra-low active current. This is ideal for providing More Battery Life™ (MoBL®) in portable

applications such as cellular telephones. The device also has an automatic power-down feature that significantly reduces power consumption. The device can also be put into standby mode when deselected ( $\overline{CE}_1$  HIGH or  $CE_2$  LOW or both BHE and BLE are HIGH). The input/output pins ( $I/O_0$  through  $I/O_{15}$ ) are placed in a high-impedance state when: deselected ( $\overline{CE}_1$  HIGH or  $CE_2$  LOW), outputs are disabled ( $\overline{OE}$  HIGH), both Byte High Enable and Byte Low Enable are disabled (BHE, BLE HIGH), or during a write operation ( $\overline{CE}_1$  LOW,  $CE_2$  HIGH and WE LOW).

Writing to the device is accomplished by taking Chip Enables ( $\overline{CE}_1$  LOW and  $CE_2$  HIGH) and Write Enable (WE) input LOW. If Byte Low Enable ( $\overline{BLE}$ ) is LOW, then data from  $I/O$  pins ( $I/O_0$  through  $I/O_7$ ), is written into the location specified on the address pins ( $A_0$  through  $A_{20}$ ). If Byte High Enable (BHE) is LOW, then data from  $I/O$  pins ( $I/O_8$  through  $I/O_{15}$ ) is written into the location specified on the address pins ( $A_0$  through  $A_{20}$ ).

Reading from the device is accomplished by taking Chip Enables ( $\overline{CE}_1$  LOW and  $CE_2$  HIGH) and Output Enable ( $\overline{OE}$ ) LOW while forcing the Write Enable (WE) HIGH. If Byte Low Enable (BLE) is LOW, then data from the memory location specified by the address pins will appear on  $I/O_0$  to  $I/O_7$ . If Byte High Enable (BHE) is LOW, then data from memory will appear on  $I/O_8$  to  $I/O_{15}$ . See the truth table for a complete description of read and write modes.

## Logic Block Diagram

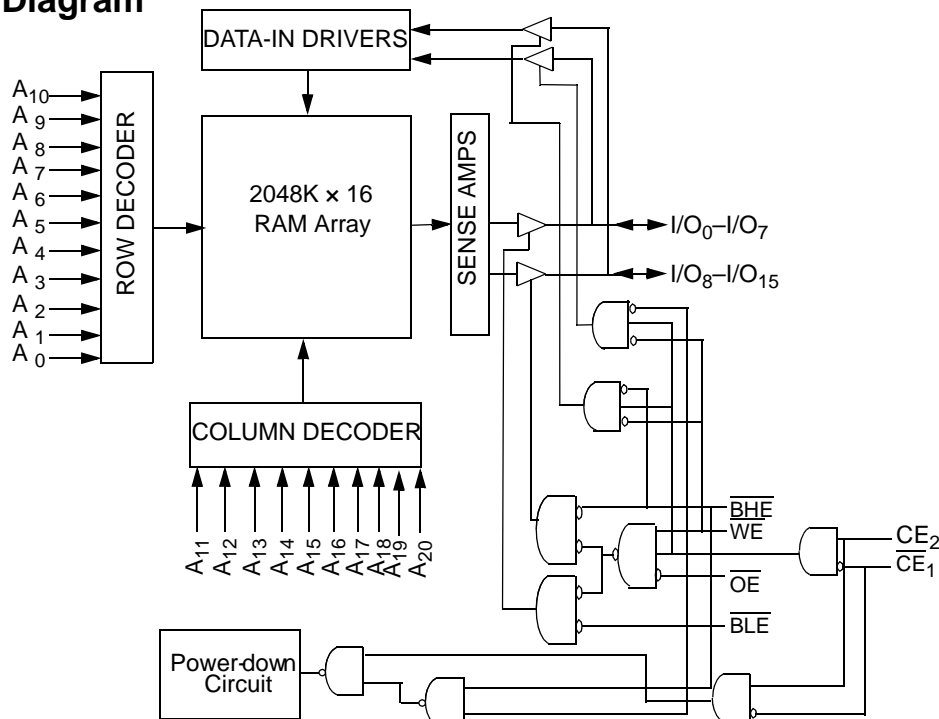

## Contents

<b>Pin Configuration</b> .....	<b>3</b>	<b>Truth Table</b> .....	<b>10</b>
<b>Product Portfolio</b> .....	<b>3</b>	<b>Ordering Information</b> .....	<b>10</b>
<b>Maximum Ratings</b> .....	<b>4</b>	Ordering Code Definitions .....	10
<b>Operating Range</b> .....	<b>4</b>	<b>Package Diagram</b> .....	<b>11</b>
<b>Electrical Characteristics Over the Operating Range</b> ...	<b>4</b>	<b>Reference Information</b> .....	<b>11</b>
<b>Thermal Resistance</b> .....	<b>5</b>	Acronyms .....	11
<b>AC Test Loads and Waveforms</b> .....	<b>5</b>	Document Conventions .....	11
<b>Data Retention Characteristics</b>		<b>Document History Page</b> .....	<b>12</b>
<b>(Over the Operating Range)</b> .....	<b>5</b>	<b>Sales, Solutions, and Legal Information</b> .....	<b>13</b>
<b>Data Retention Waveform</b> .....	<b>6</b>	Worldwide Sales and Design Support .....	13
<b>Switching Characteristics Over the Operating Range</b> ..	<b>6</b>	Products .....	13
<b>Switching Waveforms</b> .....	<b>7</b>	PSoC Solutions .....	13

Pin Configuration<sup>[1]</sup>

Figure 1. 48-Ball FBGATop View

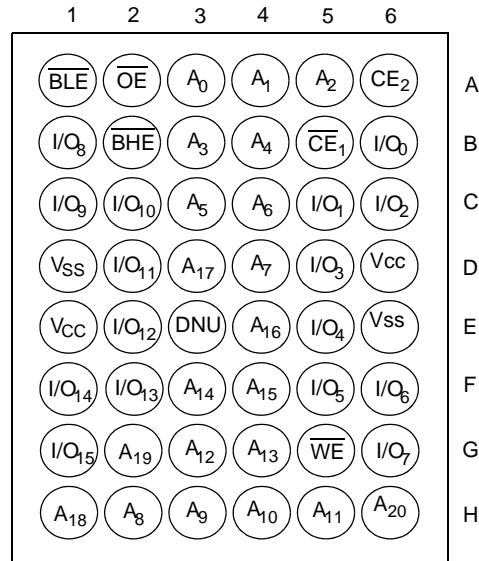

Product Portfolio

Product	V <sub>CC</sub> Range (V)			Speed (ns)	Power Dissipation					
					Operating I <sub>CC</sub> (mA)				Standby I <sub>SB2</sub> ( $\mu$ A)	
	f = 1 MHz		f = f <sub>max</sub>							
	Min	Typ <sup>[2]</sup>	Max		Typ <sup>[2]</sup>	Max	Typ <sup>[2]</sup>	Max	Typ <sup>[2]</sup>	Max
CY62177DV30LL	2.2	3.0	3.6	55	2	4	15	30	5	50

Notes

1. DNU pins have to be left floating or tied to V<sub>SS</sub> to ensure proper application.
2. Typical values are included for reference only and are not guaranteed or tested. Typical values are measured at V<sub>CC</sub> = V<sub>CC(typ)</sub>, T<sub>A</sub> = 25 °C.

## Maximum Ratings

Exceeding maximum ratings may shorten the useful life of the device. User guidelines are not tested.

Storage temperature ..... -65 °C to + 150 °C  
 Ambient temperature with power applied ..... -55 °C to + 125 °C  
 Supply voltage to ground potential ..... -0.3 V to  $V_{CC} + 0.3$  V  
 DC voltage applied to outputs in High Z state<sup>[3, 4]</sup> ..... -0.3 V to  $V_{CC} + 0.3$  V  
 DC input voltage<sup>[3, 4]</sup> ..... -0.3 V to  $V_{CC} + 0.3$  V

Output current into outputs (LOW) ..... 20 mA  
 Static discharge voltage ..... >2001 V (per MIL-STD-883, method 3015)  
 Latch-up current ..... >200 mA

## Operating Range

Device	Range	Ambient Temperature	$V_{CC}$ <sup>[5]</sup>
CY62177DV30LL	Industrial	-40 °C to +85 °C	2.20 V to 3.60 V

## Electrical Characteristics Over the Operating Range

Parameter	Description	Test Conditions	Min	Typ <sup>[6]</sup>	Max	Unit	
$V_{OH}$	Output HIGH voltage	$I_{OH} = -0.1$ mA	$V_{CC} = 2.20$ V	2.0	–	–	V
		$I_{OH} = -1.0$ mA	$V_{CC} = 2.70$ V	2.4	–	–	V
$V_{OL}$	Output LOW voltage	$I_{OL} = 0.1$ mA	$V_{CC} = 2.20$ V	–	–	0.4	V
		$I_{OL} = 2.1$ mA	$V_{CC} = 2.70$ V	–	–	0.4	V
$V_{IH}$	Input HIGH voltage	$V_{CC} = 2.2$ V to 2.7 V	1.8	–	$V_{CC} + 0.3$ V	V	
		$V_{CC} = 2.7$ V to 3.6 V	2.2	–	$V_{CC} + 0.3$ V	V	
$V_{IL}$	Input LOW voltage	$V_{CC} = 2.2$ V to 2.7 V	-0.3	–	0.6	V	
		$V_{CC} = 2.7$ V to 3.6 V	-0.3	–	0.8	V	
$I_{IX}$	Input leakage current	$GND \leq V_I \leq V_{CC}$	-1	–	+1	$\mu$ A	
$I_{OZ}$	Output leakage current	$GND \leq V_O \leq V_{CC}$ , output disabled	-1	–	+1	$\mu$ A	
$I_{CC}$	$V_{CC}$ operating supply current	$f = f_{MAX} = 1/t_{RC}$	$V_{CC} = V_{CCmax}$ $I_{OUT} = 0$ mA CMOS levels	15	30	mA	
		$f = 1$ MHz		2	4	mA	
$I_{SB1}$	Automatic CE power-down current—CMOS inputs	$CE_1 \geq V_{CC} - 0.2$ V, $CE_2 < 0.2$ V, $V_{IN} \geq V_{CC} - 0.2$ V, $V_{IN} \leq 0.2$ V) $f = f_{MAX}$ (address and data only), $f = 0$ (OE, WE, BHE and BLE), $V_{CC} = 3.60$ V	–	5	100	$\mu$ A	
$I_{SB2}$	Automatic CE power-down current—CMOS inputs	$CE_1 \geq V_{CC} - 0.2$ V, $CE_2 < 0.2$ V, $V_{IN} \geq V_{CC} - 0.2$ V or $V_{IN} \leq 0.2$ V, $f = 0$ , $V_{CC} = 3.60$ V	–	5	50	$\mu$ A	

### Notes

- $V_{IL(min)}$  = -2.0 V for pulse durations less than 20 ns.
- $V_{IH(Max)}$  =  $V_{CC} + 0.75$  V for pulse durations less than 20 ns.
- Full device AC operation requires linear  $V_{CC}$  ramp from 0 to  $V_{CC(min)}$   $\geq 500$   $\mu$ s.
- Typical values are included for reference only and are not guaranteed or tested. Typical values are measured at  $V_{CC} = V_{CC(typ)}$ ,  $T_A = 25$  °C

**Capacitance**

Parameter <sup>[7]</sup>	Description	Test Conditions	Max.	Unit
C <sub>IN</sub>	Input capacitance	T <sub>A</sub> = 25 °C, f = 1 MHz, V <sub>CC</sub> = V <sub>CC(typ)</sub>	12	pF
C <sub>OUT</sub>	Output capacitance		12	pF

**Thermal Resistance**

Parameter <sup>[7]</sup>	Description	Test Conditions	BGA	Unit
θ <sub>JA</sub>	Thermal resistance (Junction to ambient)	Still Air, soldered on a 3 × 4.5 inch, two-layer printed circuit board	55	°C/W
θ <sub>JC</sub>	Thermal resistance (Junction to case)		16	°C/W

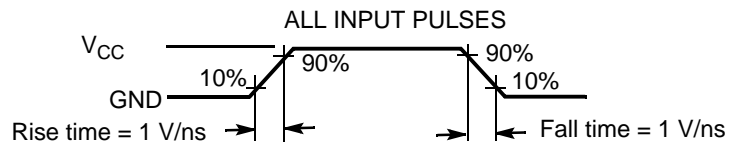
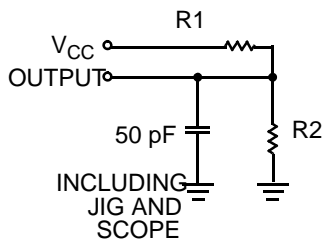
**AC Test Loads and Waveforms**

Equivalent to: THÉVENIN EQUIVALENT

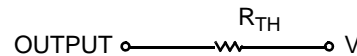

Parameters	2.5 V (2.2 V to 2.7 V)	3.0 V (2.7 V to 3.6 V)	Unit
R1	16667	1103	Ω
R2	15385	1554	Ω
R <sub>TH</sub>	8000	645	Ω
V <sub>TH</sub>	1.20	1.75	V

**Data Retention Characteristics (Over the Operating Range)**

Parameter	Description	Conditions	Min	Typ <sup>[8]</sup>	Max	Unit
V <sub>DR</sub>	V <sub>CC</sub> for data retention		1.5	–	–	V
I <sub>CCDR</sub>	Data retention current	V <sub>CC</sub> = 1.5 V CE <sub>1</sub> ≥ V <sub>CC</sub> – 0.2 V, CE <sub>2</sub> < 0.2 V, V <sub>IN</sub> ≥ V <sub>CC</sub> – 0.2 V or V <sub>IN</sub> ≤ 0.2 V	–	–	25	μA
t <sub>CDR</sub> <sup>[7]</sup>	Chip deselect to data retention time		0	–	–	ns
t <sub>R</sub> <sup>[9]</sup>	Operation recovery time		55	–	–	ns

**Notes**

7. Tested initially and after any design or process changes that may affect these parameters.
8. Typical values are included for reference only and are not guaranteed or tested. Typical values are measured at V<sub>CC</sub> = V<sub>CC(typ)</sub>, T<sub>A</sub> = 25 °C
9. Full device operation requires linear V<sub>CC</sub> ramp from V<sub>DR</sub> to V<sub>CC(min.)</sub> ≥ 100 μs or stable at V<sub>CC(min.)</sub> ≥ 100 μs.

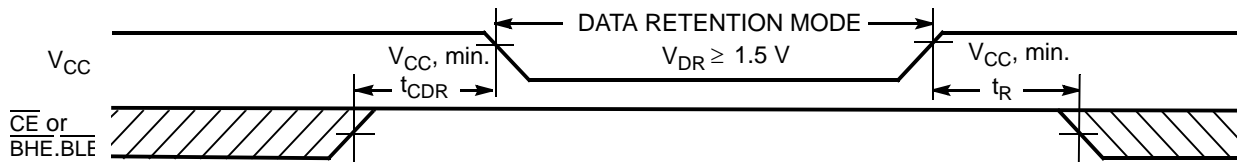
**Data Retention Waveform<sup>[10, 11]</sup>**

**Switching Characteristics Over the Operating Range**

Parameter <sup>[11, 12]</sup>	Description	Min	Max	Unit
<b>READ CYCLE</b>				
$t_{RC}$	Read cycle time	55	–	ns
$t_{AA}$	Address to data valid	–	55	ns
$t_{OHA}$	Data hold from address change	10	–	ns
$t_{ACE}$	$\overline{CE}$ LOW to data valid	–	55	ns
$t_{DOE}$	$\overline{OE}$ LOW to data valid	–	25	ns
$t_{LZOE}$	$\overline{OE}$ LOW to LOW Z <sup>[13]</sup>	5	–	ns
$t_{HZOE}$	$\overline{OE}$ HIGH to High Z <sup>[13, 14]</sup>	–	20	ns
$t_{LZCE}$	$\overline{CE}$ LOW to Low Z <sup>[13]</sup>	10	–	ns
$t_{HZCE}$	$\overline{CE}$ HIGH to High Z <sup>[13, 14]</sup>	–	20	ns
$t_{PU}$	$\overline{CE}$ LOW to power-up	0	–	ns
$t_{PD}$	$\overline{CE}$ HIGH to power-down	–	55	ns
$t_{DBE}$	$\overline{BLE/BHE}$ LOW to data valid	–	55	ns
$t_{LZBE}$	$\overline{BLE/BHE}$ LOW to Low Z <sup>[13]</sup>	10	–	ns
$t_{HZBE}$	$\overline{BLE/BHE}$ HIGH to HIGH Z <sup>[13, 14]</sup>	–	20	ns
<b>WRITE CYCLE<sup>[15]</sup></b>				
$t_{WC}$	Write cycle time	55	–	ns
$t_{SCE}$	$\overline{CE}$ LOW to write end	40	–	ns
$t_{AW}$	Address set-up to write end	40	–	ns
$t_{HA}$	Address hold from write end	0	–	ns
$t_{SA}$	Address set-up to write start	0	–	ns
$t_{PWE}$	$\overline{WE}$ pulse width	40	–	ns
$t_{BW}$	$\overline{BLE/BHE}$ LOW to write end	40	–	ns
$t_{SD}$	Data set-up to write end	25	–	ns
$t_{HD}$	Data hold from write end	0	–	ns
$t_{HZWE}$	$\overline{WE}$ LOW to High Z <sup>[13, 14]</sup>	–	20	ns
$t_{LZWE}$	$\overline{WE}$ HIGH to Low Z <sup>[13]</sup>	10	–	ns

**Notes**

10.  $\overline{BHE.BLE}$  is the AND of both  $\overline{BHE}$  and  $\overline{BLE}$ . Chip can be deselected by either disabling the chip enable signals or by disabling both  $\overline{BHE}$  and  $\overline{BLE}$ .
11.  $\overline{CE}$  is the logical combination of  $\overline{CE}_1$  and  $\overline{CE}_2$ . When  $\overline{CE}_1$  is LOW and  $\overline{CE}_2$  is HIGH,  $\overline{CE}$  is LOW; when  $\overline{CE}_1$  is HIGH or  $\overline{CE}_2$  is LOW,  $\overline{CE}$  is HIGH.
12. Test conditions for all parameters other than tri-state parameters assume signal transition time of 1 ns/V, timing reference levels of  $V_{CC(\text{typ})}/2$ , input pulse levels of 0 to  $V_{CC(\text{typ})}$ , and output loading of the specified  $I_{OL}/I_{OH}$  as shown in the "AC Test Loads and Waveforms" section.
13. At any given temperature and voltage condition,  $t_{HZCE}$  is less than  $t_{LZCE}$ ,  $t_{HZBE}$  is less than  $t_{LZBE}$ ,  $t_{HZOE}$  is less than  $t_{LZOE}$ , and  $t_{HZWE}$  is less than  $t_{LZWE}$  for any given device.
14.  $t_{HZOE}$ ,  $t_{HZCE}$ ,  $t_{HZBE}$ , and  $t_{HZWE}$  transitions are measured when the outputs enter a high impedance state.
15. The internal Write time of the memory is defined by the overlap of  $\overline{WE}$ ,  $\overline{CE} = V_{IL}$ ,  $\overline{BHE}$  and/or  $\overline{BLE} = V_{IL}$ . All signals must be ACTIVE to initiate a write and any of these signals can terminate a write by going INACTIVE. The data input set-up and hold timing should be referenced to the edge of the signal that terminates the write.

### Switching Waveforms<sup>[16]</sup>

Figure 2. Read Cycle 1 (Address Transition Controlled)<sup>[17, 18]</sup>

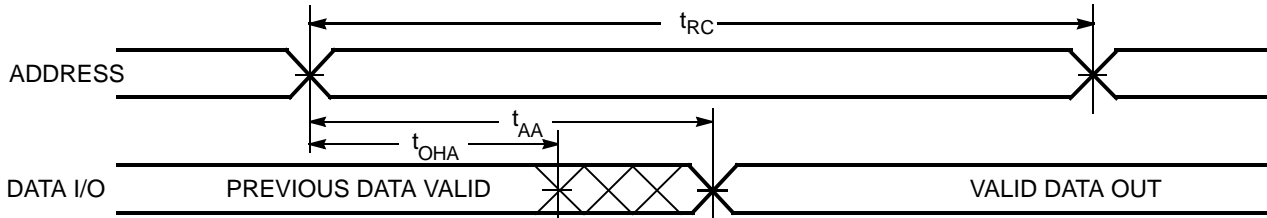
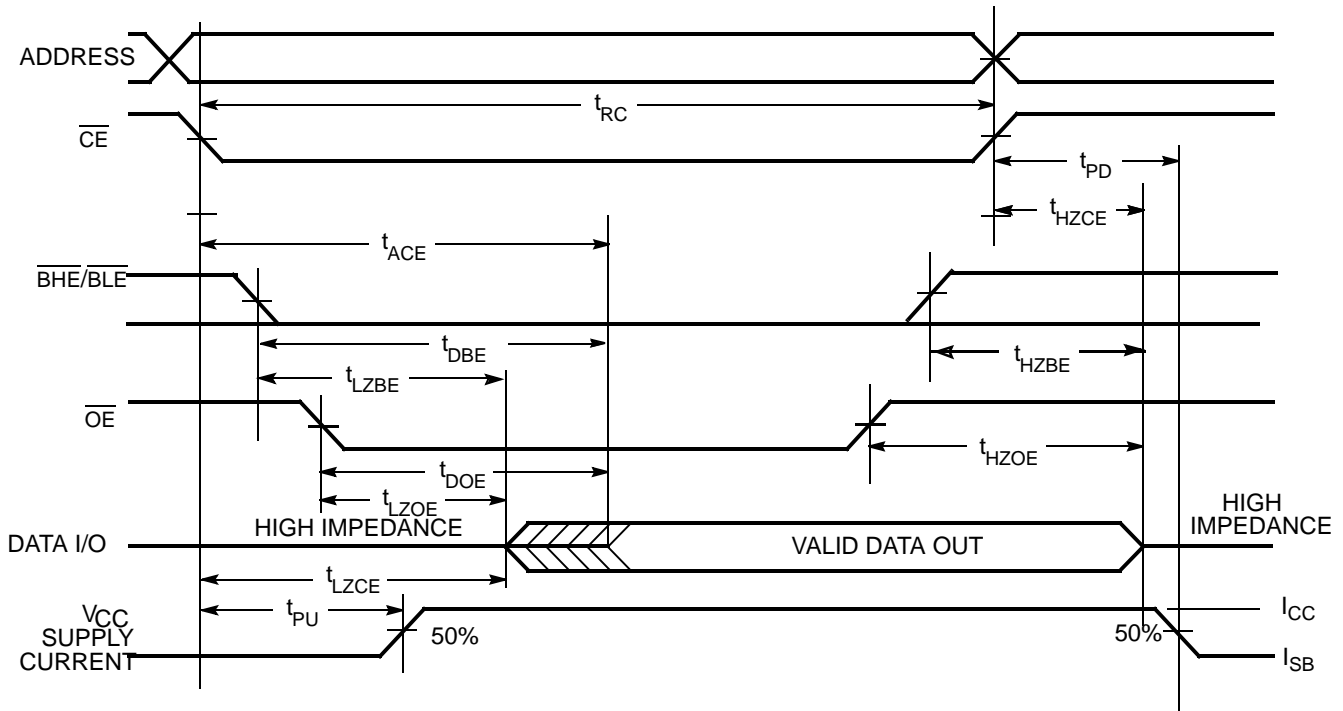

Figure 3. Read Cycle 2 ( $\overline{OE}$  Controlled)<sup>[18, 19, 20]</sup>



**Notes**

- 16. All Read/Write switching waveforms are shown for 16-bit data transactions only.
- 17. The device is continuously selected. OE, CE = V<sub>IL</sub>, BHE and/or BLE = V<sub>IL</sub>.
- 18. WE is HIGH for read cycle.
- 19. Address valid prior to or coincident with  $\overline{CE}$ ,  $\overline{BHE}$ ,  $\overline{BLE}$  transition LOW.
- 20. CE is the logical combination of CE<sub>1</sub> and CE<sub>2</sub>. When CE<sub>1</sub> is LOW and CE<sub>2</sub> is HIGH,  $\overline{CE}$  is LOW; when  $\overline{CE}$ <sub>1</sub> is HIGH or CE<sub>2</sub> is LOW,  $\overline{CE}$  is HIGH.

Switching Waveforms<sup>[16]</sup> (continued)

Figure 4. Write Cycle 1 ( $\overline{WE}$  Controlled)<sup>[21, 22, 23, 24, 25]</sup>

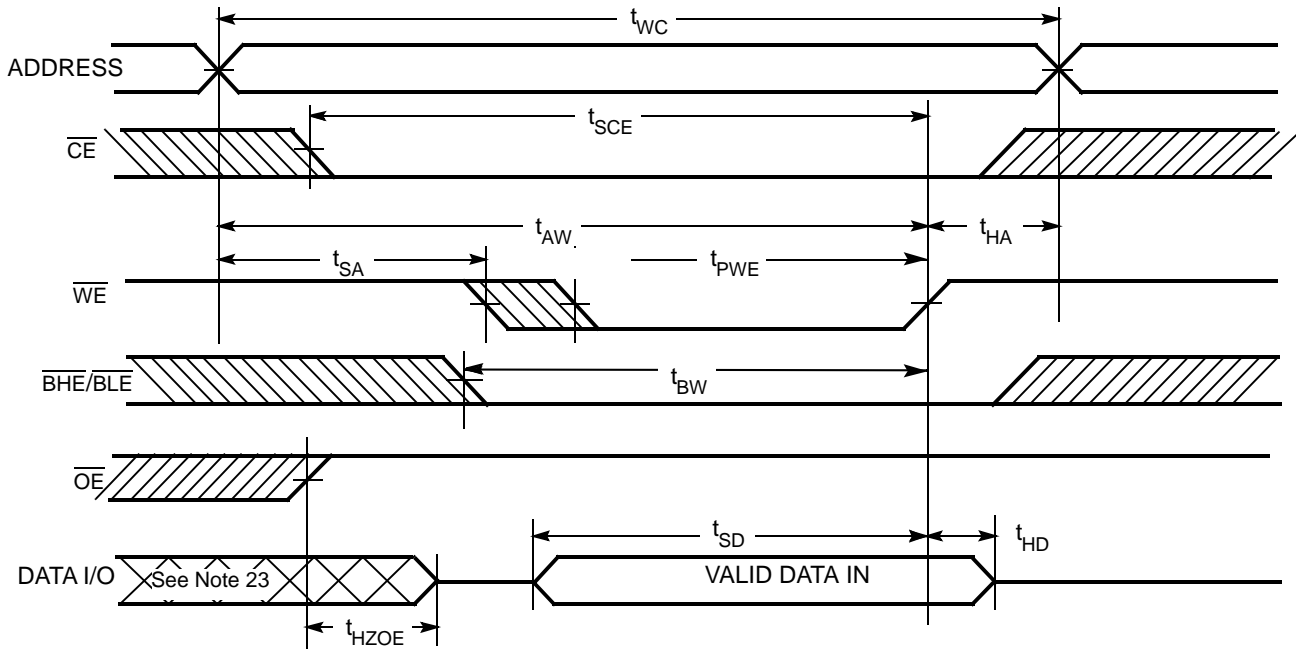
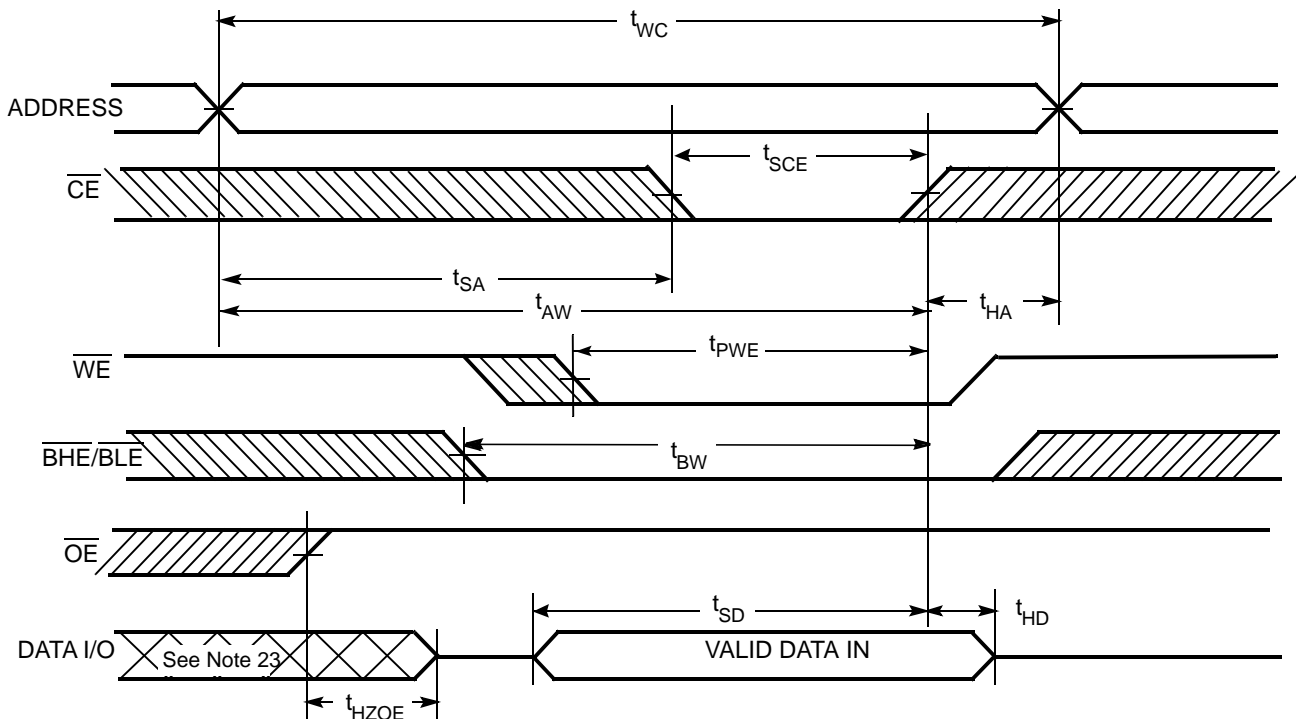

Figure 5. Write Cycle 2 ( $\overline{CE}$  Controlled)<sup>[21, 22, 23, 24, 25]</sup>



Notes

21. Data I/O is high impedance if  $\overline{OE} = V_{IH}$ .
22. If  $\overline{CE}$  goes HIGH simultaneously with  $\overline{WE} = V_{IH}$ , the output remains in a high-impedance state.
23. During this period, the I/Os are in output state and input signals should not be applied.
24.  $\overline{CE}$  is the logical combination of  $\overline{CE}_1$  and  $\overline{CE}_2$ . When  $\overline{CE}_1$  is LOW and  $\overline{CE}_2$  is HIGH,  $\overline{CE}$  is LOW; when  $\overline{CE}_1$  is HIGH or  $\overline{CE}_2$  is LOW,  $\overline{CE}$  is HIGH.
25. The internal Write time of the memory is defined by the overlap of  $\overline{WE}$ ,  $\overline{CE} = V_{IL}$ ,  $\overline{BHE}$  and/or  $\overline{BLE} = V_{IL}$ . All signals must be ACTIVE to initiate a write and any of these signals can terminate a write by going INACTIVE. The data input set-up and hold timing should be referenced to the edge of the signal that terminates the write.

Switching Waveforms<sup>[16]</sup> (continued)

Figure 6. Write Cycle 3 ( $\overline{WE}$  Controlled,  $\overline{OE}$  LOW)<sup>[26, 27, 28]</sup>

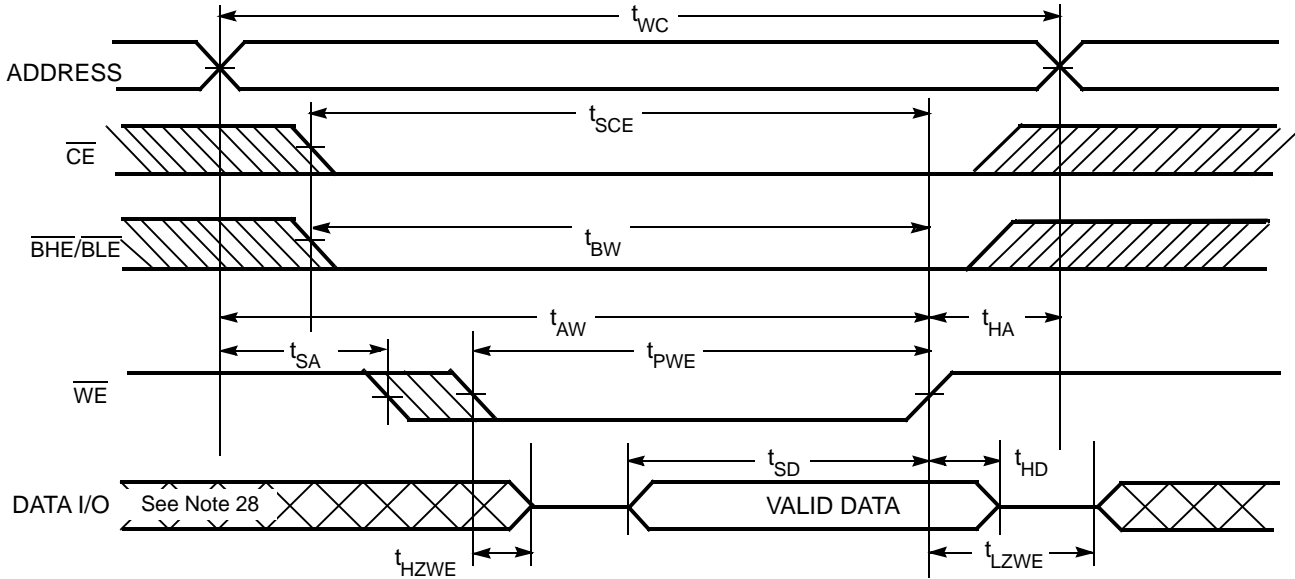
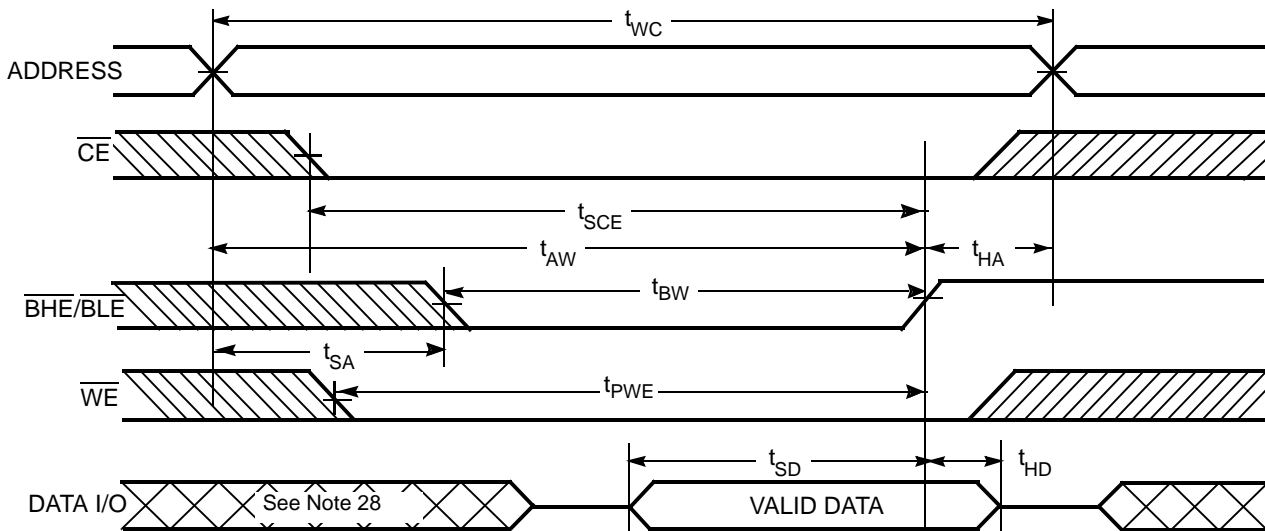

Figure 7. Write Cycle 4 ( $\overline{BHE}/\overline{BLE}$  Controlled,  $\overline{OE}$  LOW)<sup>[26, 27, 28]</sup>



Notes

- 26.  $\overline{CE}$  is the logical combination of  $\overline{CE}_1$  and  $CE_2$ . When  $\overline{CE}_1$  is LOW and  $CE_2$  is HIGH,  $\overline{CE}$  is LOW; when  $\overline{CE}_1$  is HIGH or  $CE_2$  is LOW,  $\overline{CE}$  is HIGH.
- 27. If  $\overline{CE}$  goes HIGH simultaneously with  $WE = V_{IH}$ , the output remains in a high-impedance state.
- 28. During this period, the I/Os are in output state and input signals should not be applied.

**Truth Table**

CE <sub>1</sub>	CE <sub>2</sub>	WE	OE	BHE	BLE	Inputs/Outputs	Mode	Power
H	X	X	X	X	X	High Z	Deselect/power-down	Standby (I <sub>SB</sub> )
X	L	X	X	X	X	High Z	Deselect/power-down	Standby (I <sub>SB</sub> )
X	X	X	X	H	H	High Z	Deselect/power-down	Standby (I <sub>SB</sub> )
L	H	H	L	L	L	Data out (I/O <sub>0</sub> -I/O <sub>15</sub> )	Read	Active (I <sub>CC</sub> )
L	H	H	L	H	L	Data out (I/O <sub>0</sub> -I/O <sub>7</sub> ); High Z (I/O <sub>8</sub> -I/O <sub>15</sub> )	Read	Active (I <sub>CC</sub> )
L	H	H	L	L	H	High Z (I/O <sub>0</sub> -I/O <sub>7</sub> ); Data Out (I/O <sub>8</sub> -I/O <sub>15</sub> )	Read	Active (I <sub>CC</sub> )
L	H	H	H	L	H	High Z	Output disabled	Active (I <sub>CC</sub> )
L	H	H	H	H	L	High Z	Output disabled	Active (I <sub>CC</sub> )
L	H	H	H	L	L	High Z	Output disabled	Active (I <sub>CC</sub> )
L	H	L	X	L	L	Data in (I/O <sub>0</sub> -I/O <sub>15</sub> )	Write	Active (I <sub>CC</sub> )
L	H	L	X	H	L	Data in (I/O <sub>0</sub> -I/O <sub>7</sub> ); High Z (I/O <sub>8</sub> -I/O <sub>15</sub> )	Write	Active (I <sub>CC</sub> )
L	H	L	X	L	H	High Z (I/O <sub>0</sub> -I/O <sub>7</sub> ); Data in (I/O <sub>8</sub> -I/O <sub>15</sub> )	Write	Active (I <sub>CC</sub> )

**Ordering Information**

Speed (ns)	Ordering Code	Package Diagram	Package Type	Operating Range
55	CY62177DV30LL-55BAXI	51-85191	48-ball FBGA (8 mm × 9.5 mm × 1.2 mm) (Pb-free)	Industrial

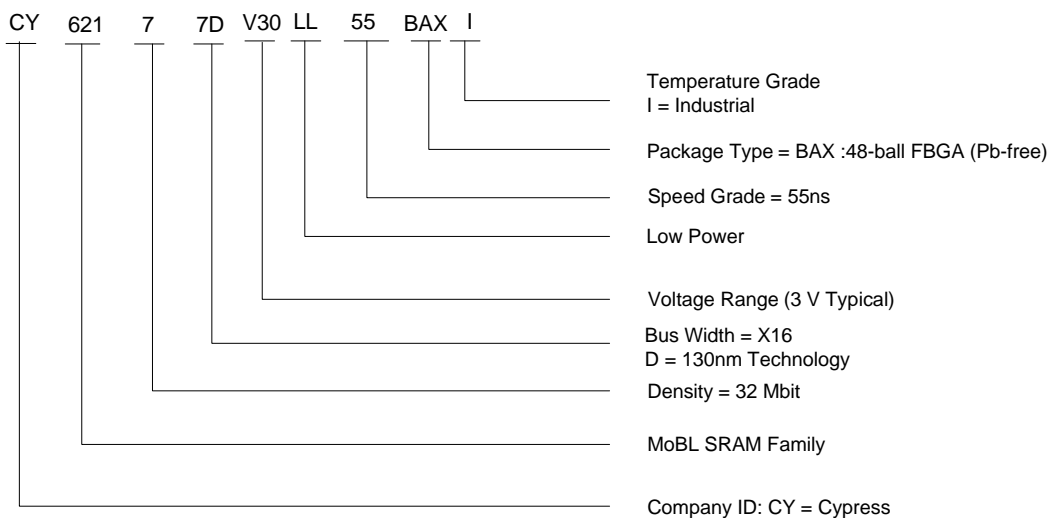
**Ordering Code Definitions**

## Package Diagram

Figure 8. 48 ball FBGA (8 × 9.5 × 1.2 mm) (51-85191)

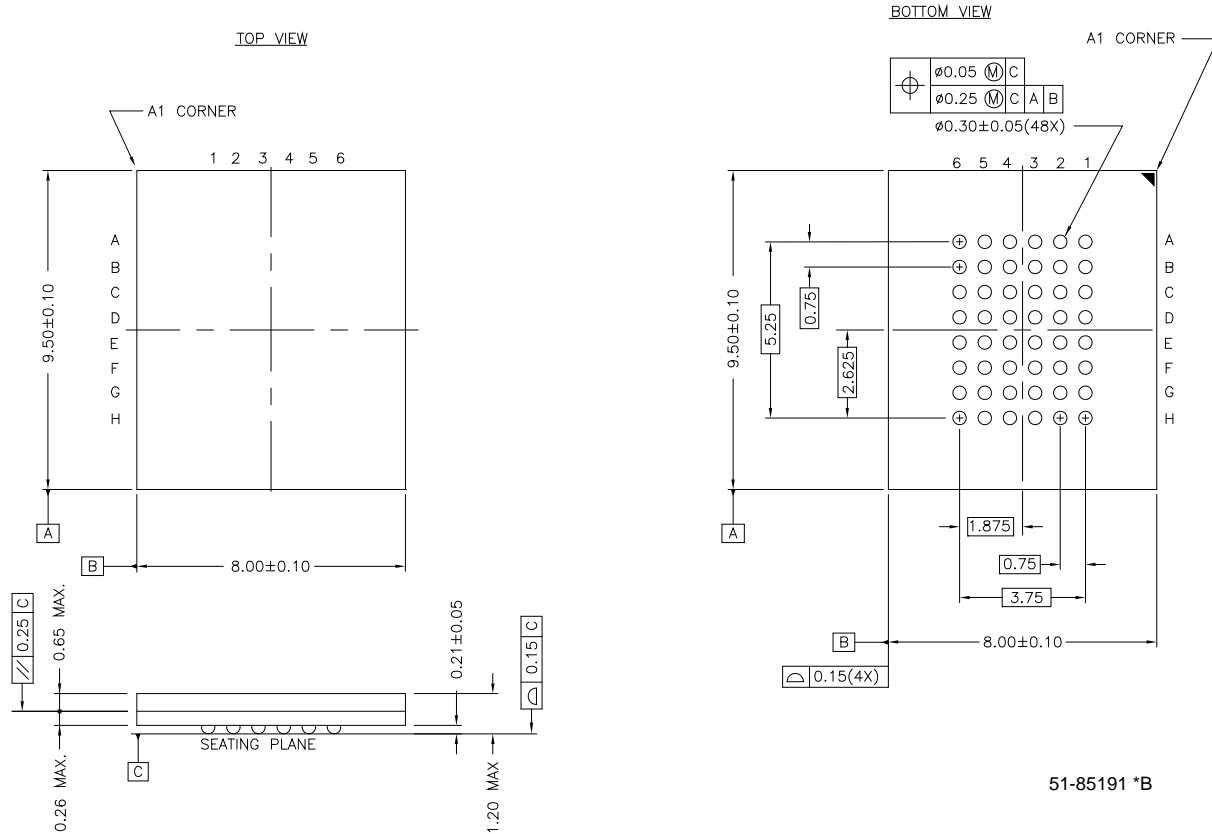

## Reference Information

### Acronyms

Acronym	Description
CMOS	complementary metal oxide semiconductor
I/O	input/output
SRAM	static random access memory
FBGA	fine ball grid array

### Document Conventions

#### Units of Measure

Symbol	Unit of Measure
°C	degrees Celsius
μA	microampere
mA	milliampere
MHz	megahertz
ns	nanosecond
pF	picofarad
V	volt
Ω	ohm
W	watt

**Document History Page**

Document Title: CY62177DV30 MoBL® 32-Mbit (2 M x 16) Static RAM Document #: 38-05633				
Revision	ECN	Orig. of Change	Submission Date	Description of Change
**	251075	AJU	See ECN	New Datasheet
*A	330363	AJU	See ECN	Changed title of data sheet from CYM62177DV30 to CY62177DV30 Added second chip enable (CE <sub>2</sub> ) Added footnote #12 on page 5
*B	400960	NXR	See ECN	Changed address of Cypress Semiconductor Corporation on Page# 1 from "3901 North First Street" to "198 Champion Court" Changed I <sub>SB1</sub> from 60 and 40 μA to 100 μA for the L and LL versions for both the 55 and the 70 ns speed bins respectively.
*C	469187	NXR	See ECN	Converted from Preliminary to Final Changed the I <sub>SB2(Max)</sub> from 40 μA to 50 μA for LL version of both 45 ns and 55 ns speed bins Changed the I <sub>CCDR(Max)</sub> from 20 μA to 25 μA for LL version Updated the Ordering Information table
*D	2896036	AJU	03/19/10	Removed inactive parts from Ordering Information. Updated package diagram. Updated links in Sales, Solutions, and Legal Information.
*E	3153110	RAME	01/25/2011	Updated datasheet as per template Removed CY62177DV30L related info Removed 70 ns speed bin related info Added <a href="#">Ordering Code Definitions</a> Added <a href="#">Reference Information</a> and <a href="#">Units of Measure</a> table
*F	3329873	RAME	07/27/11	Removed footnote # 8 and its reference because of single package availability. Updated template and styles according to current Cypress standards. Added acronyms and units. Removed reference to AN1064 SRAM system guidelines.
*G	3685455	MEMJ	07/20/2012	Added Note 16. Updated text in Switching Waveforms diagrams. Updated Package Diagram.

## Sales, Solutions, and Legal Information

### Worldwide Sales and Design Support

Cypress maintains a worldwide network of offices, solution centers, manufacturer's representatives, and distributors. To find the office closest to you, visit us at [Cypress Locations](#).

### Products

<a href="#">Automotive</a>	<a href="#">cypress.com/go/automotive</a>
<a href="#">Clocks &amp; Buffers</a>	<a href="#">cypress.com/go/clocks</a>
<a href="#">Interface</a>	<a href="#">cypress.com/go/interface</a>
<a href="#">Lighting &amp; Power Control</a>	<a href="#">cypress.com/go/powerpsoc</a> <a href="#">cypress.com/go/plc</a>
<a href="#">Memory</a>	<a href="#">cypress.com/go/memory</a>
<a href="#">PSoC</a>	<a href="#">cypress.com/go/psoc</a>
<a href="#">Touch Sensing</a>	<a href="#">cypress.com/go/touch</a>
<a href="#">USB Controllers</a>	<a href="#">cypress.com/go/USB</a>
<a href="#">Wireless/RF</a>	<a href="#">cypress.com/go/wireless</a>

### PSoC Solutions

[psoc.cypress.com/solutions](#)  
PSoC 1 | PSoC 3 | PSoC 5

---

© Cypress Semiconductor Corporation, 2006-2012. The information contained herein is subject to change without notice. Cypress Semiconductor Corporation assumes no responsibility for the use of any circuitry other than circuitry embodied in a Cypress product. Nor does it convey or imply any license under patent or other rights. Cypress products are not warranted nor intended to be used for medical, life support, life saving, critical control or safety applications, unless pursuant to an express written agreement with Cypress. Furthermore, Cypress does not authorize its products for use as critical components in life-support systems where a malfunction or failure may reasonably be expected to result in significant injury to the user. The inclusion of Cypress products in life-support systems application implies that the manufacturer assumes all risk of such use and in doing so indemnifies Cypress against all charges.

Any Source Code (software and/or firmware) is owned by Cypress Semiconductor Corporation (Cypress) and is protected by and subject to worldwide patent protection (United States and foreign), United States copyright laws and international treaty provisions. Cypress hereby grants to licensee a personal, non-exclusive, non-transferable license to copy, use, modify, create derivative works of, and compile the Cypress Source Code and derivative works for the sole purpose of creating custom software and or firmware in support of licensee product to be used only in conjunction with a Cypress integrated circuit as specified in the applicable agreement. Any reproduction, modification, translation, compilation, or representation of this Source Code except as specified above is prohibited without the express written permission of Cypress.

Disclaimer: CYPRESS MAKES NO WARRANTY OF ANY KIND, EXPRESS OR IMPLIED, WITH REGARD TO THIS MATERIAL, INCLUDING, BUT NOT LIMITED TO, THE IMPLIED WARRANTIES OF MERCHANTABILITY AND FITNESS FOR A PARTICULAR PURPOSE. Cypress reserves the right to make changes without further notice to the materials described herein. Cypress does not assume any liability arising out of the application or use of any product or circuit described herein. Cypress does not authorize its products for use as critical components in life-support systems where a malfunction or failure may reasonably be expected to result in significant injury to the user. The inclusion of Cypress' product in a life-support systems application implies that the manufacturer assumes all risk of such use and in doing so indemnifies Cypress against all charges.

Use may be limited by and subject to the applicable Cypress software license agreement.