

Features

- Asynchronous First-In First-Out (FIFO) Buffer Memories
 - 512 × 9 (CY7C421)
- Dual-Ported RAM Cell
- High Speed 50 MHz Read and Write Independent of Depth and Width
- Low Operating Power: $I_{CC} = 35$ mA
- Empty and Full Flags (Half Full Flag in Standalone)
- TTL Compatible
- Retransmit in Standalone
- Expandable in Width
- PLCC, 7 × 7 TQFP, 300-Mil Molded SOJ
- Pb-free Packages Available
- Pin Compatible and Functionally Equivalent to IDT7201, and AM7201

Functional Description

The CY7C421 is a first-in first-out (FIFO) memory offered in 300-mil wide SOJ, TQFP & PLCC packages and it is 512 words by 9 bits wide. Each FIFO memory is organized such that the

data is read in the same sequential order that it was written. Full and empty flags are provided to prevent overflow and underflow. Three additional pins are also provided to facilitate unlimited expansion in width, depth, or both. The depth expansion technique steers the control signals from one device to another in parallel. This eliminates the serial addition of propagation delays, so that throughput is not reduced. Data is steered in a similar manner.

The read and write operations may be asynchronous; each can occur at a rate of 50 MHz. The write operation occurs when the write (\overline{W}) signal is LOW. Read occurs when read (\overline{R}) goes LOW. The nine data outputs go to the high impedance state when \overline{R} is HIGH.

A Half Full (\overline{HF}) output flag that is valid in the standalone and width expansion configurations is provided. In the depth expansion configuration, this pin provides the expansion out (\overline{XO}) information that is used to tell the next FIFO that it is activated.

In the standalone and width expansion configurations, a LOW on the retransmit (\overline{RT}) input causes the FIFO to retransmit the data. Read enable (\overline{R}) and write enable (\overline{W}) must both be HIGH during retransmit, and then \overline{R} is used to access the data.

The CY7C421 is fabricated using an advanced 0.65-micron P-well CMOS technology. Input ESD protection is greater than 2000 V and latch up is prevented by careful layout and guard rings.

Selection Guide

| | | |
|----------------------------------|-----|------|
| 512 × 9 | -15 | -20 |
| Frequency (MHz) | 40 | 33.3 |
| Maximum Access Time (ns) | 15 | 20 |
| I_{CC1} (mA) | 35 | 35 |

Logic Block Diagram

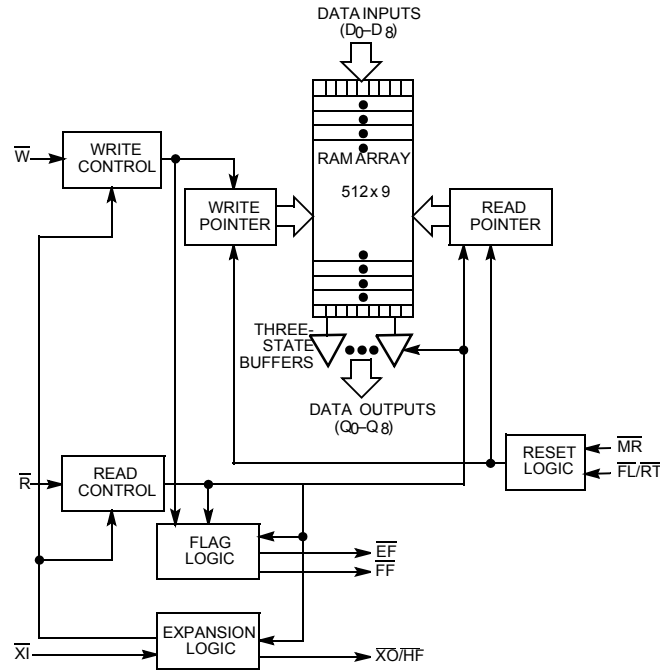

Contents

| | | | |
|--|-----------|--|-----------|
| Pin Configurations | 4 | Standalone/Width Expansion Modes | 13 |
| Pin Definitions | 5 | Depth Expansion Mode | 13 |
| Maximum Ratings | 6 | Use of the Empty and Full Flags | 14 |
| Operating Range | 6 | Ordering Information | 15 |
| Electrical Characteristics | 6 | Ordering Code Definitions | 15 |
| Electrical Characteristics | 6 | Package Diagrams | 16 |
| Capacitance | 6 | Acronyms | 19 |
| AC Test Loads and Waveforms | 7 | Document Conventions | 19 |
| Switching Characteristics | 8 | Units of Measure | 19 |
| Switching Waveforms | 9 | Document History Page | 20 |
| Architecture | 13 | Sales, Solutions, and Legal Information | 21 |
| Dual-Port RAM | 13 | Worldwide Sales and Design Support | 21 |
| Resetting the FIFO | 13 | Products | 21 |
| Writing Data to the FIFO | 13 | PSoC Solutions | 21 |
| Reading Data from the FIFO | 13 | | |

Pin Configurations

Figure 1. 32-pin PLCC/LCC (Top View)

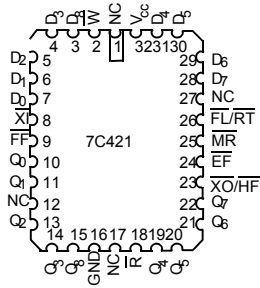

Figure 2. 28-pin DIP (Top View)

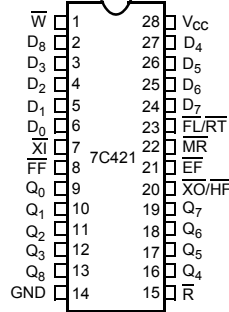
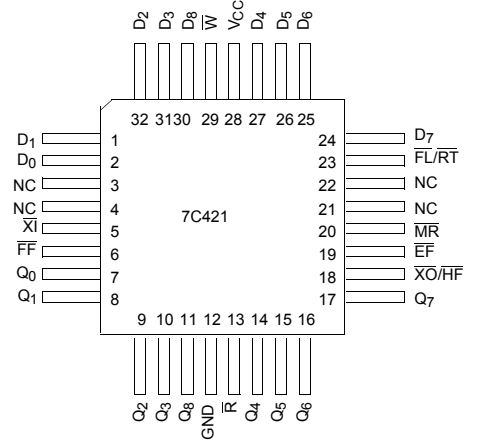

Figure 3. 32-pin TQFP (Top View)



Pin Definitions

| Signal Name | Description | I/O | Function |
|-----------------|----------------|-----|--|
| \overline{W} | Write Signal | I | Write into the FIFO |
| \overline{R} | Read Signal | I | Read from the FIFO |
| D_0-D_8 | Input Data | I | Data into the FIFO |
| Q_0-Q_8 | Output Data | O | Data Out from the FIFO |
| \overline{XI} | Expansion In | I | Cascaded: Connected to \overline{XO} of pervious device Non-Cascaded: Connected to V_{CC} |
| \overline{XO} | Expansion Out | O | Cascaded: Connected to \overline{XI} of next device Non-Cascaded: Connected to V_{CC} |
| \overline{HF} | Half Full Flag | O | Half-full flag: When \overline{HF} is LOW, half of the FIFO is full. |
| \overline{FF} | Full Flag | O | When \overline{FF} is LOW, the FIFO is full. |
| \overline{EF} | Empty Flag | O | When \overline{EF} is LOW, the FIFO is empty. |
| \overline{MR} | Master Reset | I | FIFO Reset |
| \overline{RT} | Retransmit | I | Causes FIFO to retransmit the data |
| \overline{FL} | First Load | I | Width expansion: Connected to V_{CC} Depth expansion: when Gnd indicates that part is first to be loaded all others connected to V_{CC} |
| V_{CC} | Power | I | Voltage Supply |
| GND | Ground | I | Ground |

Maximum Ratings

Exceeding maximum ratings may impair the useful life of the device. These user guidelines are not tested.^[1]

| | |
|---|-------------------|
| Storage Temperature | -65 °C to +150 °C |
| Ambient Temperature with Power Applied | -55 °C to +125 °C |
| Supply Voltage to Ground Potential | -0.5 V to +7.0 V |
| DC Voltage Applied to Outputs in High Z State | -0.5 V to +7.0 V |
| DC Input Voltage | -0.5 V to +7.0 V |

| | |
|---|----------|
| Power Dissipation | 1.0 W |
| Output Current, into Outputs (LOW) | 20 mA |
| Static Discharge Voltage (per MIL-STD-883, Method 3015) | > 2000 V |
| Latch Up Current | > 200 mA |

Operating Range

| Range | Ambient Temperature ^[2] | V _{CC} |
|------------|------------------------------------|-----------------|
| Commercial | 0 °C to +70 °C | 5 V ± 10% |
| Industrial | -40 °C to +85 °C | 5 V ± 10% |

Electrical Characteristics

Over the Operating Range

| Parameter | Description | Test Conditions | All Speed Grades | | Unit | |
|-----------------|---|--|------------------|-----|-----------------|---|
| | | | Min | Max | | |
| V _{OH} | Output HIGH Voltage | V _{CC} = Min, I _{OH} = -2.0 mA | 2.4 | - | V | |
| V _{OL} | Output LOW Voltage | V _{CC} = Min, I _{OL} = 8.0 mA | - | 0.4 | V | |
| V _{IH} | Input HIGH Voltage | | Commercial | 2.0 | V _{CC} | V |
| | | | Industrial | 2.2 | V _{CC} | |
| V _{IL} | Input LOW Voltage | | [3] | 0.8 | V | |
| I _{Ix} | Input Leakage Current | GND ≤ V _I ≤ V _{CC} | -10 | +10 | μA | |
| I _{OZ} | Output Leakage Current | $\bar{R} \geq V_{IH}$, GND ≤ V _O ≤ V _{CC} | -10 | +10 | μA | |
| I _{OS} | Output Short Circuit Current ^[4] | V _{CC} = Max, V _{OUT} = GND | - | -90 | mA | |

Electrical Characteristics

Over the Operating Range

| Parameter | Description | Test Conditions | -15 | | -20 | | Unit | |
|------------------|--------------------|--|------------|-----|-----|-----|------|----|
| | | | Min | Max | Min | Max | | |
| I _{CC} | Operating Current | V _{CC} = Max, I _{OUT} = 0 mA, f = f _{MAX} | Commercial | - | 65 | - | 55 | mA |
| | | | Industrial | - | 100 | - | 90 | |
| I _{CC1} | Operating Current | V _{CC} = Max, I _{OUT} = 0 mA, f = 20 MHz | Commercial | - | 35 | - | 35 | mA |
| I _{SB1} | Standby Current | All Inputs = V _{IH} Min | Commercial | - | 10 | - | 10 | mA |
| | | | Industrial | - | 15 | - | 15 | |
| I _{SB2} | Power Down Current | All Inputs ≥ V _{CC} - 0.2 V | Commercial | - | 5 | - | 5 | mA |
| | | | Industrial | - | 8 | - | 8 | |

Capacitance

| Parameter ^[5] | Description | Test Conditions | Max | Unit |
|--------------------------|--------------------|--|-----|------|
| C _{IN} | Input Capacitance | T _A = 25 °C, f = 1 MHz, V _{CC} = 4.5 V | 6 | pF |
| C _{OUT} | Output Capacitance | | 6 | pF |

Notes

1. Single Power Supply: The voltage on any input or I/O pin cannot exceed the power pin during power up.
2. T_A is the "instant on" case temperature.
3. V_{IL(Min)} = -2.0 V for pulse durations of less than 20 ns.
4. For test purposes, not more than one output at a time should be shorted. Short circuit test duration should not exceed 30 seconds.
5. Tested initially and after any design or process changes that may affect these parameters.

AC Test Loads and Waveforms

Figure 4. AC Test Loads and Waveforms

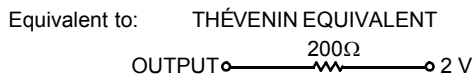
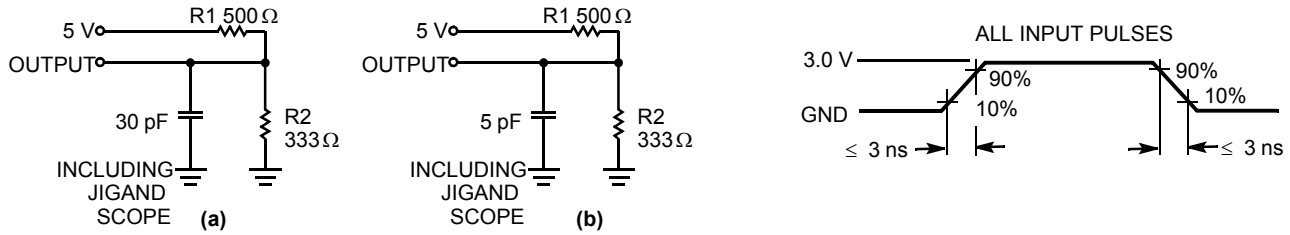

Switching Characteristics

Over the Operating Range

| Parameter ^[6] | Description | -15 | | -20 | | Unit |
|--------------------------|---|-----|-----|-----|-----|------|
| | | Min | Max | Min | Max | |
| t_{RC} | Read Cycle Time | 25 | – | 30 | – | ns |
| t_A | Access Time | – | 15 | – | 20 | ns |
| t_{RR} | Read Recovery Time | 10 | – | 10 | – | ns |
| t_{PR} | Read Pulse Width | 15 | – | 20 | – | ns |
| $t_{LZR}^{[7]}$ | Read LOW to Low Z | 3 | – | 3 | – | ns |
| $t_{DVR}^{[7, 8]}$ | Data Valid after Read HIGH | 5 | – | 5 | – | ns |
| $t_{HZR}^{[7, 8]}$ | Read HIGH to High Z | – | 15 | – | 15 | ns |
| t_{WC} | Write Cycle Time | 25 | – | 30 | – | ns |
| t_{PW} | Write Pulse Width | 15 | – | 20 | – | ns |
| $t_{HWZ}^{[7]}$ | Write HIGH to Low Z | 5 | – | 5 | – | ns |
| t_{WR} | Write Recovery Time | 10 | – | 10 | – | ns |
| t_{SD} | Data Setup Time | 8 | – | 12 | – | ns |
| t_{HD} | Data Hold Time | 0 | – | 0 | – | ns |
| t_{MRSC} | MR Cycle Time | 25 | – | 30 | – | ns |
| t_{PMR} | MR Pulse Width | 15 | – | 20 | – | ns |
| t_{RMR} | MR Recovery Time | 10 | – | 10 | – | ns |
| t_{RPW} | Read HIGH to MR HIGH | 15 | – | 20 | – | ns |
| t_{WPW} | Write HIGH to MR HIGH | 15 | – | 20 | – | ns |
| t_{RTC} | Retransmit Cycle Time | 25 | – | 30 | – | ns |
| t_{PRT} | Retransmit Pulse Width | 15 | – | 20 | – | ns |
| t_{RTR} | Retransmit Recovery Time | 10 | – | 10 | – | ns |
| t_{EFL} | MR to EF LOW | – | 25 | – | 30 | ns |
| t_{HFH} | MR to HF HIGH | – | 25 | – | 30 | ns |
| t_{FFH} | MR to FF HIGH | – | 25 | – | 30 | ns |
| t_{REF} | Read LOW to EF LOW | – | 15 | – | 20 | ns |
| t_{RFF} | Read HIGH to FF HIGH | – | 15 | – | 20 | ns |
| t_{WEF} | Write HIGH to EF HIGH | – | 15 | – | 20 | ns |
| t_{WFF} | Write LOW to FF LOW | – | 15 | – | 20 | ns |
| t_{WHF} | Write LOW to HF LOW | – | 15 | – | 20 | ns |
| t_{RHF} | Read HIGH to HF HIGH | – | 15 | – | 20 | ns |
| t_{RAE} | Effective Read from Write HIGH | – | 15 | – | 20 | ns |
| t_{RPE} | Effective Read Pulse Width after EF HIGH | 15 | – | 20 | – | ns |
| t_{WAF} | Effective Write from Read HIGH | – | 15 | – | 20 | ns |
| t_{WPF} | Effective Write Pulse Width after FF HIGH | 15 | – | 20 | – | ns |
| t_{XOL} | Expansion Out LOW Delay from Clock | – | 15 | – | 20 | ns |
| t_{XOH} | Expansion Out HIGH Delay from Clock | – | 15 | – | 20 | ns |

Notes

6. Test conditions assume signal transition time of 3 ns or less, timing reference levels of 1.5 V and output loading of the specified I_{OL}/I_{OH} and 30 pF load capacitance, as in part (a) of Figure 4 on page 7, unless otherwise specified.
7. t_{HZR} transition is measured at +200 mV from V_{OL} and –200 mV from V_{OH} . t_{DVR} transition is measured at the 1.5V level. t_{HWZ} and t_{LZR} transition is measured at ± 100 mV from the steady state.
8. t_{HZR} and t_{DVR} use capacitance loading as in part (b) of Figure 4 on page 7.

Switching Waveforms

Figure 5. Asynchronous Read and Write

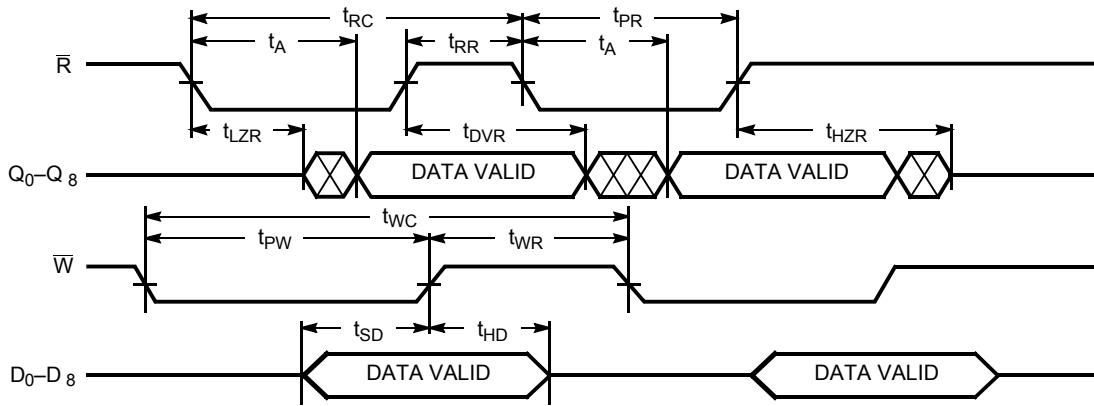

Figure 6. Master Reset

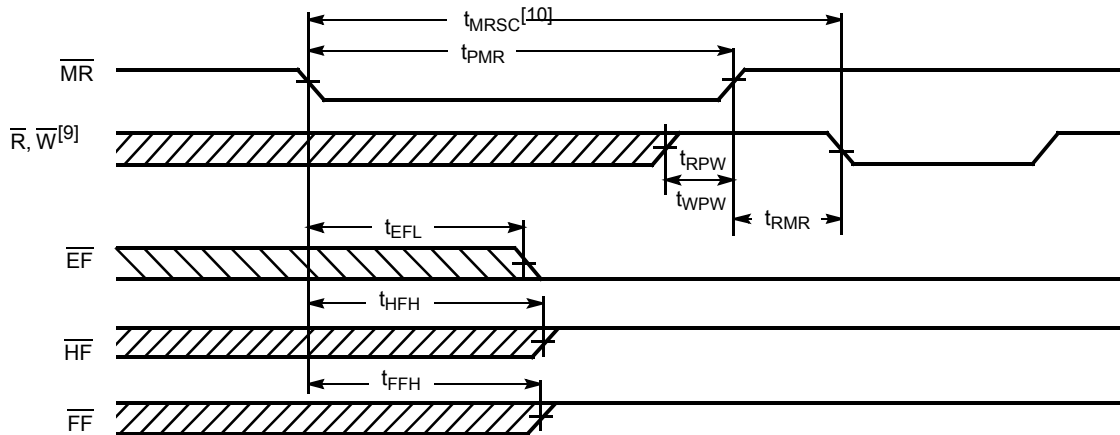
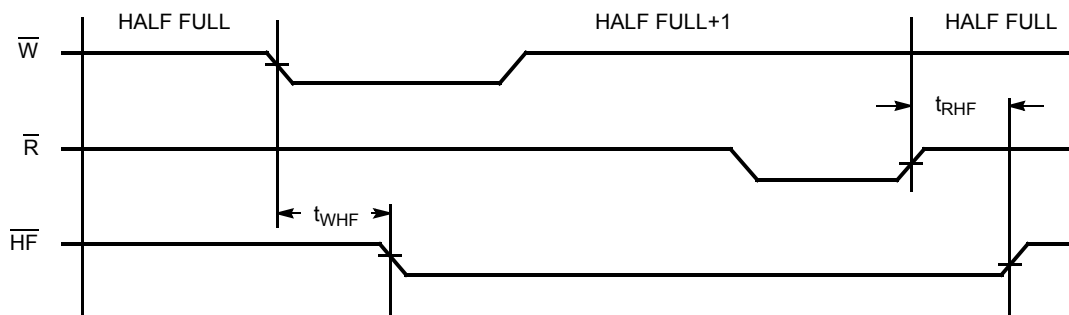

Figure 7. Half-full Flag



Notes

- 9. \overline{W} and $\overline{R} \geq V_{IH}$ around the rising edge of \overline{MR} .
- 10. $t_{MRSC} = t_{PMR} + t_{RMR}$.

Switching Waveforms (continued)

Figure 8. Last Write to First Read Full Flag

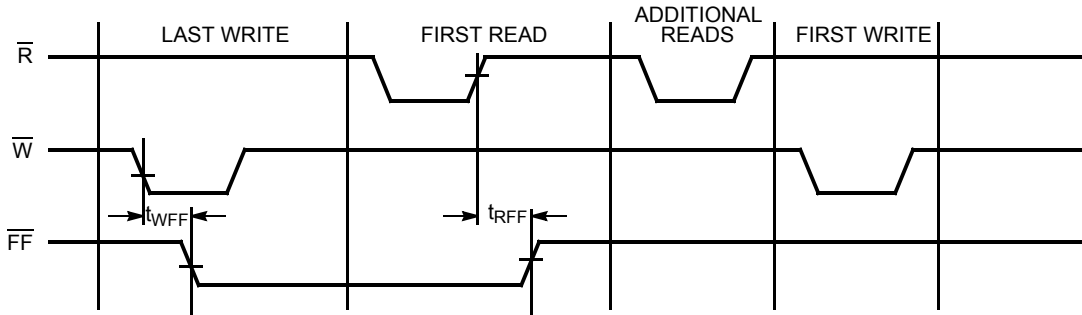

Figure 9. Last Read to First Write Empty Flag

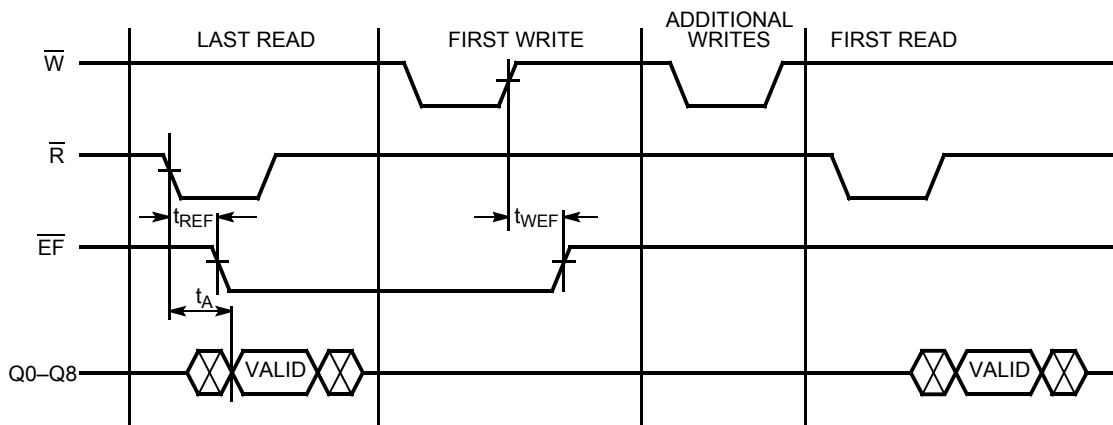
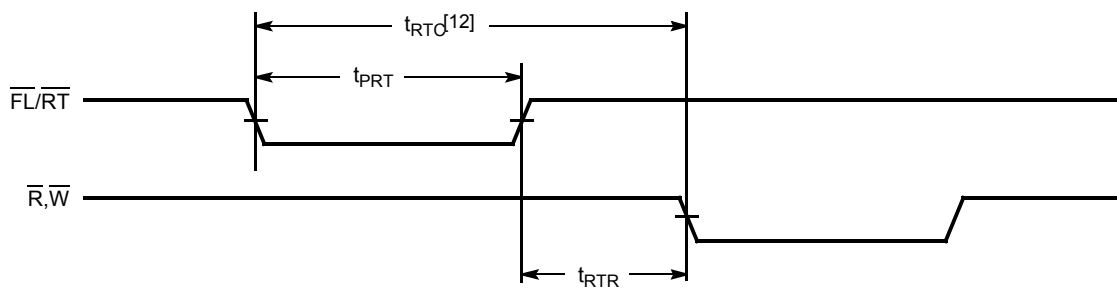

Figure 10. Retransmit^[11]



Notes

- 11. \overline{EF} , \overline{HF} and \overline{FF} may change state during retransmit as a result of the offset of the read and write pointers, but flags are valid at t_{RTD} .
- 12. $t_{RTD} = t_{PRT} + t_{RTR}$.

Switching Waveforms (continued)

Figure 11. Empty Flag and Read Data Flow-through Mode

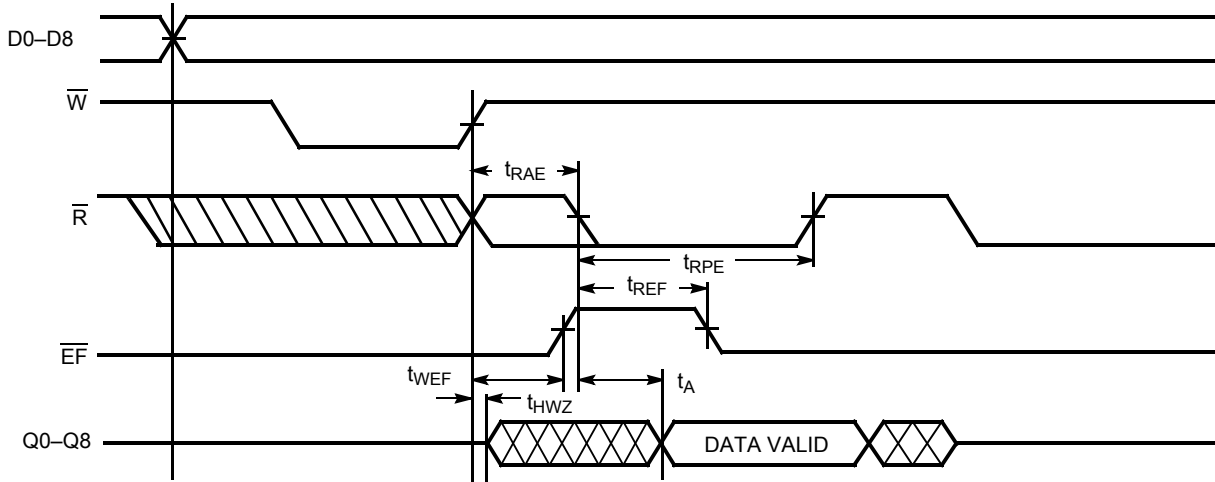
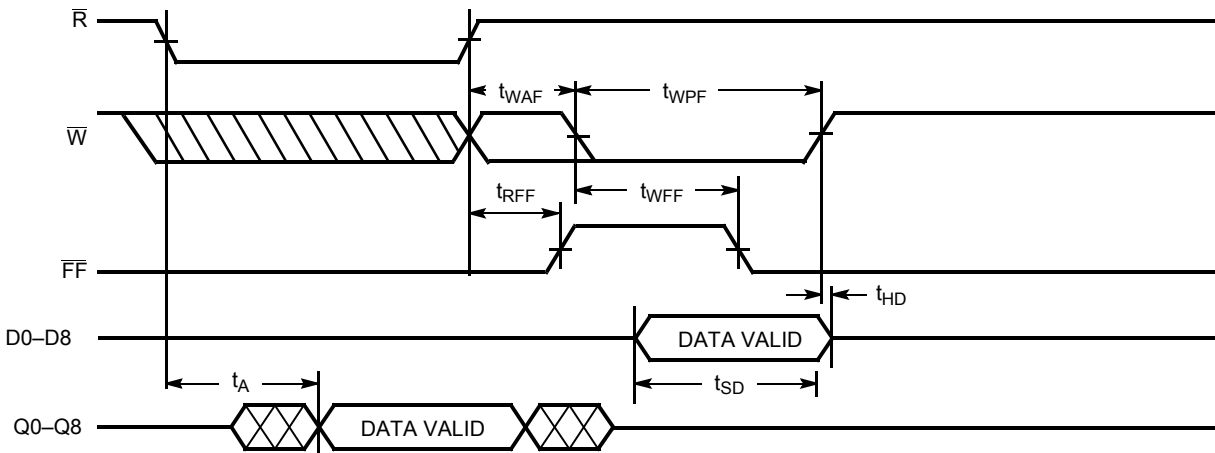
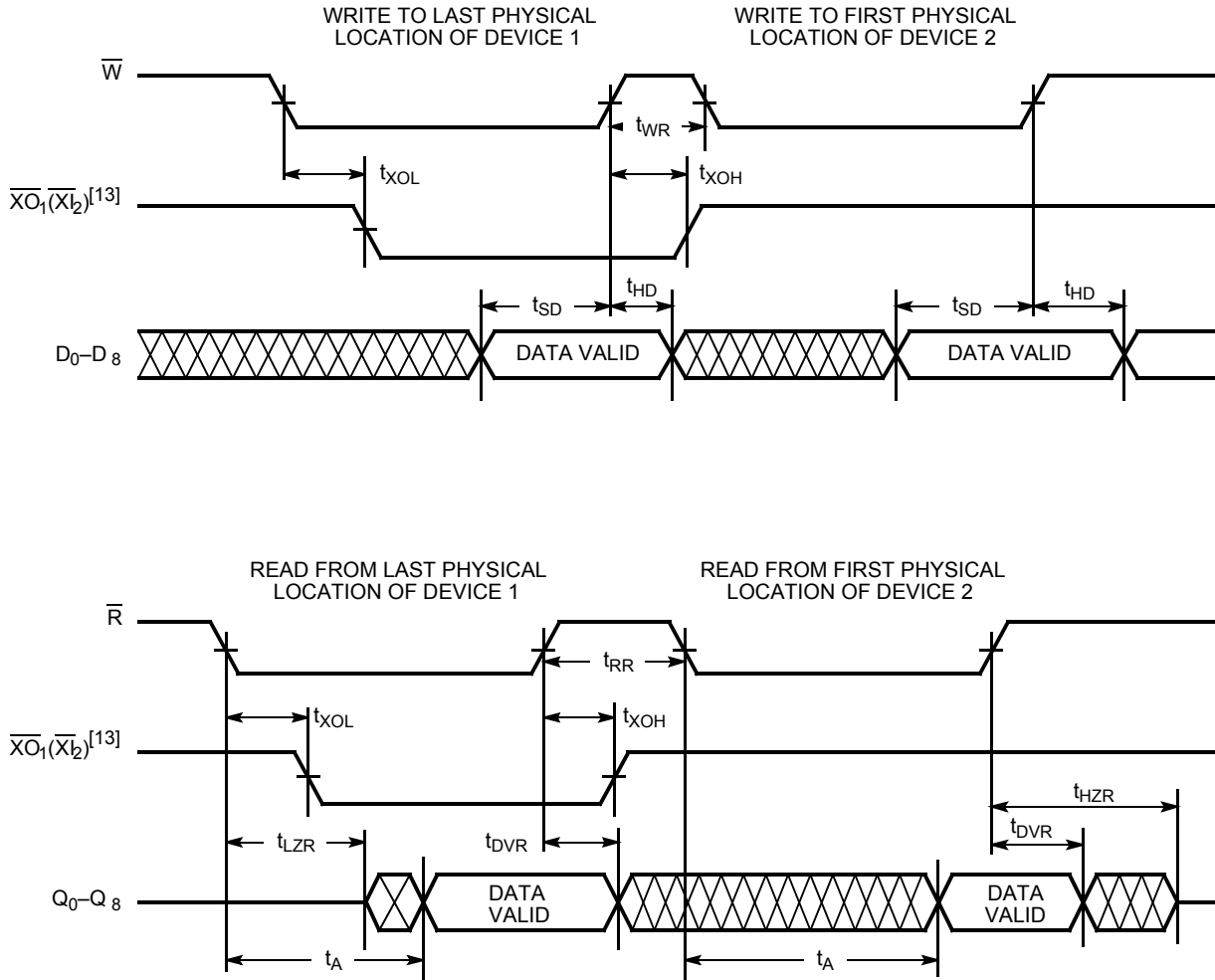

Figure 12. Full Flag and Write Data Flow-through Mode



Switching Waveforms (continued)

Figure 13. Expansion Timing Diagrams



Note
 13. Expansion Out of device 1 (\bar{XO}_1) is connected to Expansion In of device 2 (\bar{XI}_2).

Architecture

The CY7C421 FIFO consist of an array of 512 words of 9 bits each (implemented by an array of dual-port RAM cells), a read pointer, a write pointer, control signals (\overline{W} , \overline{R} , \overline{XI} , \overline{XO} , \overline{FL} , \overline{RT} , \overline{MR}), and Full, Half Full, and Empty flags.

Dual-Port RAM

The dual-port RAM architecture refers to the basic memory cell used in the RAM. The cell itself enables the read and write operations to be independent of each other, which is necessary to achieve truly asynchronous operation of the inputs and outputs. A second benefit is that the time required to increment the read and write pointers is much less than the time required for data propagation through the memory, which is the case if memory is implemented using the conventional register array architecture.

Resetting the FIFO

Upon power up, the FIFO must be reset with a Master Reset (\overline{MR}) cycle. This causes the FIFO to enter the empty condition signified by the Empty flag (\overline{EF}) being LOW, and both the Half Full (\overline{HF}) and Full flags (\overline{FF}) being HIGH. Read (\overline{R}) and write (\overline{W}) must be HIGH t_{RPW}/t_{WPW} before and t_{RMR} after the rising edge of \overline{MR} for a valid reset cycle. If reading from the FIFO after a reset cycle is attempted, the outputs are in the high impedance state.

Writing Data to the FIFO

The availability of at least one empty location is indicated by a HIGH \overline{FF} . The falling edge of \overline{W} initiates a write cycle. Data appearing at the inputs (D_0 – D_8) t_{SD} before and t_{HD} after the rising edge of \overline{W} are stored sequentially in the FIFO.

The \overline{EF} LOW-to-HIGH transition occurs t_{WEF} after the first LOW-to-HIGH transition of \overline{W} for an empty FIFO. \overline{HF} goes LOW t_{WHF} after the falling edge of \overline{W} following the FIFO actually being Half Full. Therefore, the \overline{HF} is active after the FIFO is filled to half its capacity plus one word. \overline{HF} remains LOW while less than one half of total memory is available for writing. The LOW-to-HIGH transition of \overline{HF} occurs t_{RHF} after the rising edge of \overline{R} when the FIFO goes from half full +1 to half full. \overline{HF} is available in standalone and width expansion modes. \overline{FF} goes LOW t_{WFF} after the falling edge of \overline{W} , during the cycle in which the last available location is filled. Internal logic prevents FIFO overflow. Writes to a full FIFO are ignored and the write pointer is not incremented. \overline{FF} goes HIGH t_{RFF} after a read from a full FIFO.

Reading Data from the FIFO

The falling edge of \overline{R} initiates a read cycle provided \overline{EF} is not LOW. Data outputs (Q_0 – Q_8) are in a high impedance condition between read operations (\overline{R} HIGH), when the FIFO is empty, or when the FIFO is not the active device in the depth expansion mode.

When one word is in the FIFO, the falling edge of \overline{R} initiates a HIGH-to-LOW transition of \overline{EF} . The rising edge of \overline{R} causes the data outputs to go to the high impedance state and remain such until a write is performed. Reads to an empty FIFO are ignored and do not increment the read pointer. From the empty condition, the FIFO can be read t_{WEF} after a valid write.

The retransmit feature is beneficial when transferring packets of data. It enables the receiver to acknowledge receipt of data and retransmit, if necessary.

The Retransmit (\overline{RT}) input is active in the standalone and width expansion modes. The retransmit feature is intended for use when a number of writes equal to or less than the depth of the FIFO have occurred since the last \overline{MR} cycle. A LOW pulse on \overline{RT} resets the internal read pointer to the first physical location of the FIFO. \overline{R} and \overline{W} must both be HIGH for t_{PRT} and t_{RTR} after retransmit is asserted. With every read cycle after retransmit, the data from the first physical location of FIFO is read until the read pointer equals write pointer. Full, Half Full, and Empty flags are governed by the relative locations of the read and write pointers and are updated during a retransmit cycle. Data written to the FIFO after activation of \overline{RT} are also transmitted. Full depth of FIFO data can be repeatedly retransmitted.

Standalone/Width Expansion Modes

Standalone and width expansion modes are set by grounding Expansion In (\overline{XI}) and tying First Load (\overline{FL}) to V_{CC} . FIFOs can be expanded in width to provide word widths greater than nine in increments of nine. During width expansion mode, all control line inputs are common to all devices, and flag outputs from any device can be monitored.

Depth Expansion Mode

Depth expansion mode (see Figure 14 on page 14) is entered when, during a \overline{MR} cycle, Expansion Out (\overline{XO}) of one device is connected to Expansion In (\overline{XI}) of the next device, with \overline{XO} of the last device connected to \overline{XI} of the first device. In the depth expansion mode the First Load (\overline{FL}) input, when grounded, indicates that this part is the first to be loaded. All other devices must have this pin HIGH. To enable the correct FIFO, \overline{XO} is pulsed LOW when the last physical location of the previous FIFO is written to and pulsed LOW again when the last physical location is read. Only one FIFO is enabled for read and one for write at any particular time. All other devices are in standby.

FIFOs can also be expanded simultaneously in depth and width. Consequently, any depth or width FIFO can be created of word widths in increments of 9. When expanding in depth, a composite \overline{FF} must be created by ORing the \overline{FF} s together. Likewise, a composite \overline{EF} is created by ORing the \overline{EF} s together. \overline{HF} and \overline{RT} functions are not available in depth expansion mode.

Use of the Empty and Full Flags

To achieve maximum frequency, the flags must be valid at the beginning of the next cycle. However, because they can be updated by either edge of the read or write signal, they must be valid by one-half of a cycle. Cypress FIFOs meet this requirement.

The reason for why the flags should be valid by the next cycle is complex. The “effective pulse width violation” phenomenon can occur at the full and empty boundary conditions, if the flags are not properly used. The empty flag must be used to prevent reading from an empty FIFO and the full flag must be used to prevent writing into a full FIFO.

For example, consider an empty FIFO that is receiving read pulses. Because the FIFO is empty, the read pulses are ignored by the FIFO, and nothing happens. Next, a single word is written into the FIFO, with a signal that is asynchronous to the read signal. The (internal) state machine in the FIFO goes from empty to empty+1. However, it does this asynchronously with respect to the read signal, so that the effective pulse width of the read signal cannot be determined, because the state machine does not look at the read signal until it goes to the empty+1 state. Similarly, the minimum write pulse width may be violated by trying to write into a full FIFO, and asynchronously performing a read. The empty and full flags are used to avoid these effective pulse width violations, but to do this and operate at the maximum frequency, the flag must be valid at the beginning of the next cycle.

Figure 14. Depth Expansion

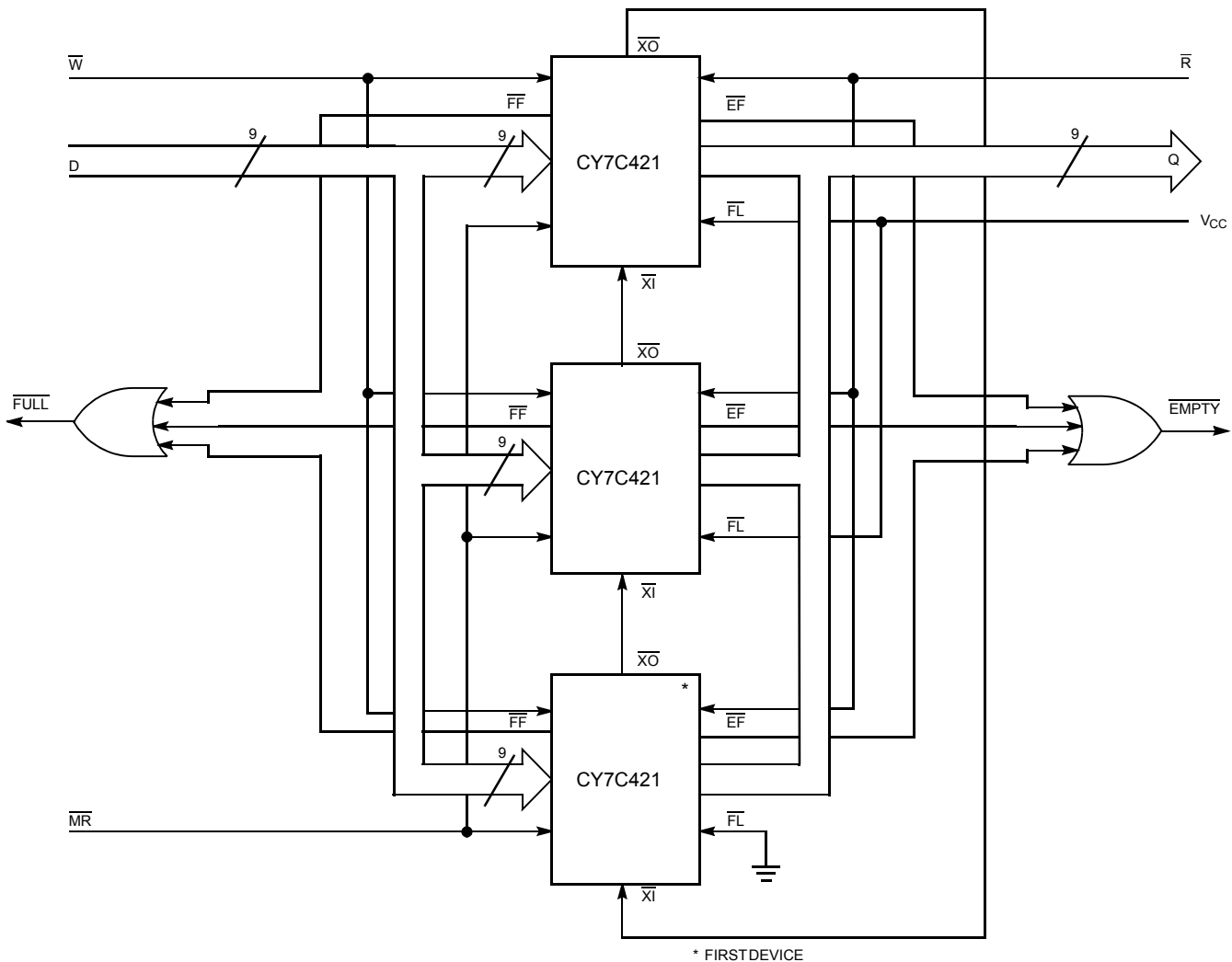

Ordering Information

| Speed (ns) | Ordering Code | Package Diagram | Package Type | Operating Range |
|------------|---------------|-----------------|---|-----------------|
| 15 | CY7C421-15AXC | 51-85063 | 32-pin Thin Quad Flat Pack (Pb-free) | Commercial |
| 20 | CY7C421-20JXC | 51-85002 | 32-pin Plastic Leaded Chip Carriers (Pb-free) | Commercial |
| | CY7C421-20VXC | 51-85031 | 28-pin (300 Mils) Molded Small Outline J-Lead (Pb-free) | |
| | CY7C421-20JXI | 51-85002 | 32-pin Plastic Leaded Chip Carrier (Pb-free) | Industrial |

Ordering Code Definitions

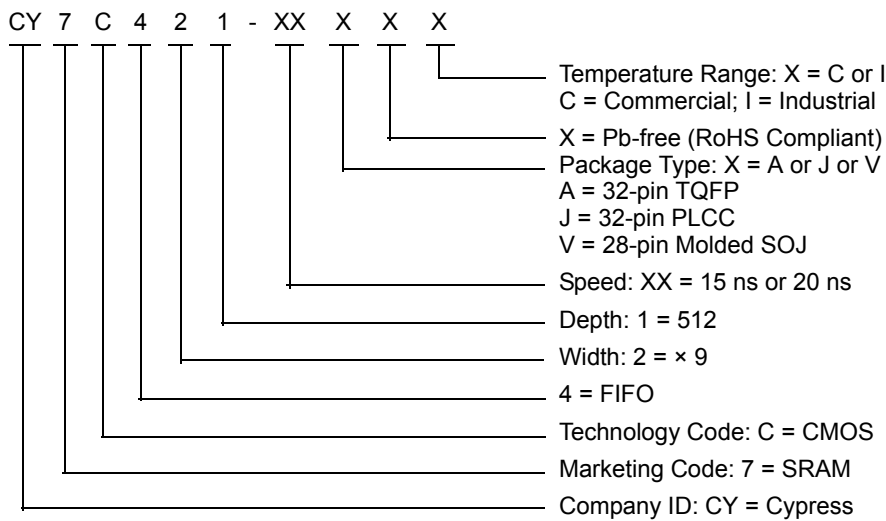

Package Diagrams

Figure 15. 32-pin TQFP (7 × 7 × 1.0 mm) A3210 Package Outline, 51-85063

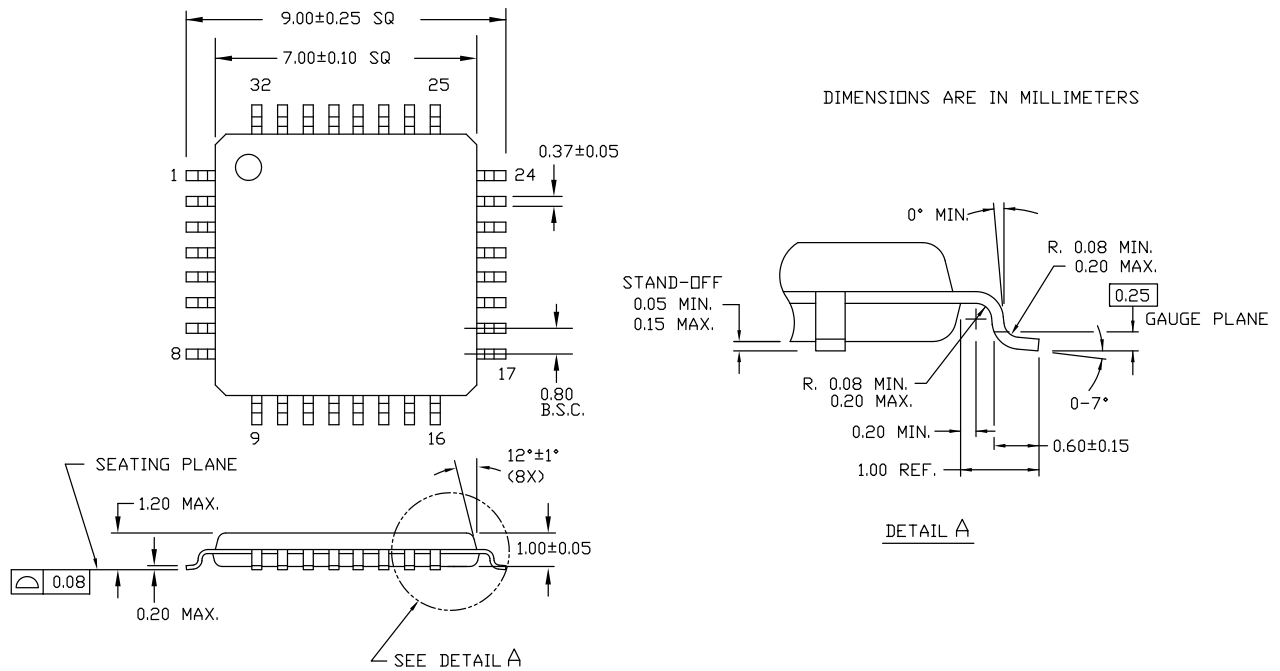

51-85063 *D

Package Diagrams (continued)

Figure 16. 32-pin PLCC (0.453 × 0.553 Inches) J32 Package Outline, 51-85002

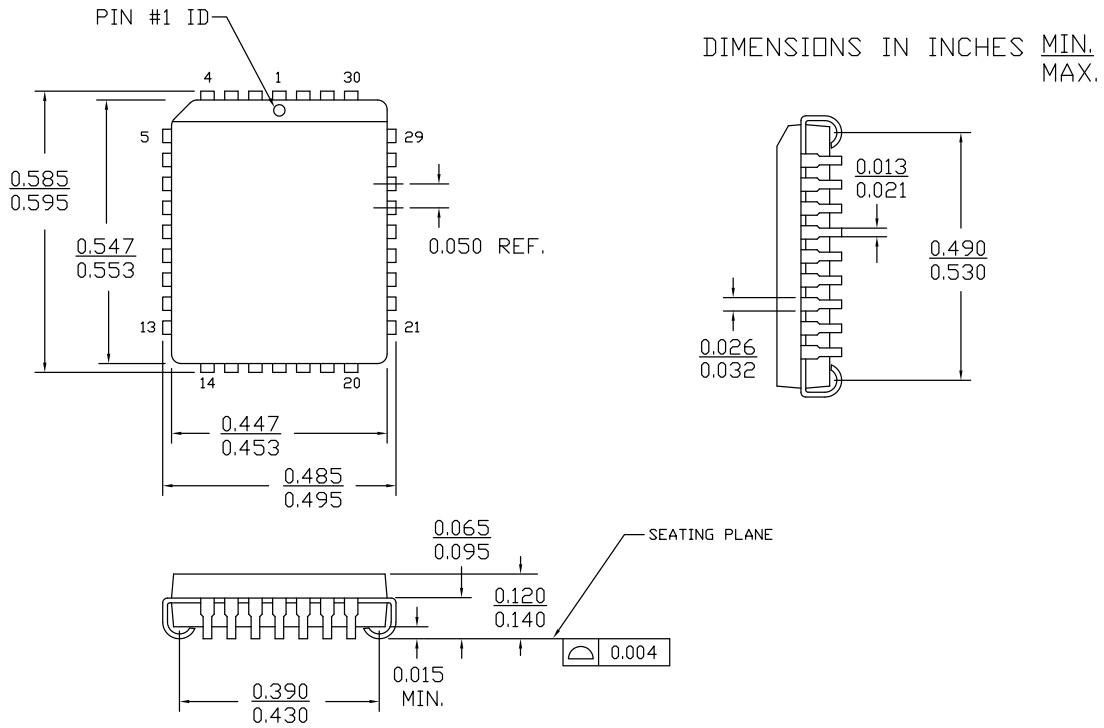

51-85002 *D

Package Diagrams (continued)

Figure 17. 28-pin SOJ (300 Mils) V28.3 (Molded SOJ V21) Package Outline, 51-85031

NOTE :

1. JEDEC STD REF MO088
2. BODY LENGTH DIMENSION DOES NOT INCLUDE MOLD PROTRUSION/END FLASH
MOLD PROTRUSION/END FLASH SHALL NOT EXCEED 0.006 in (0.152 mm) PER SIDE
3. DIMENSIONS IN INCHES MIN.
MAX.

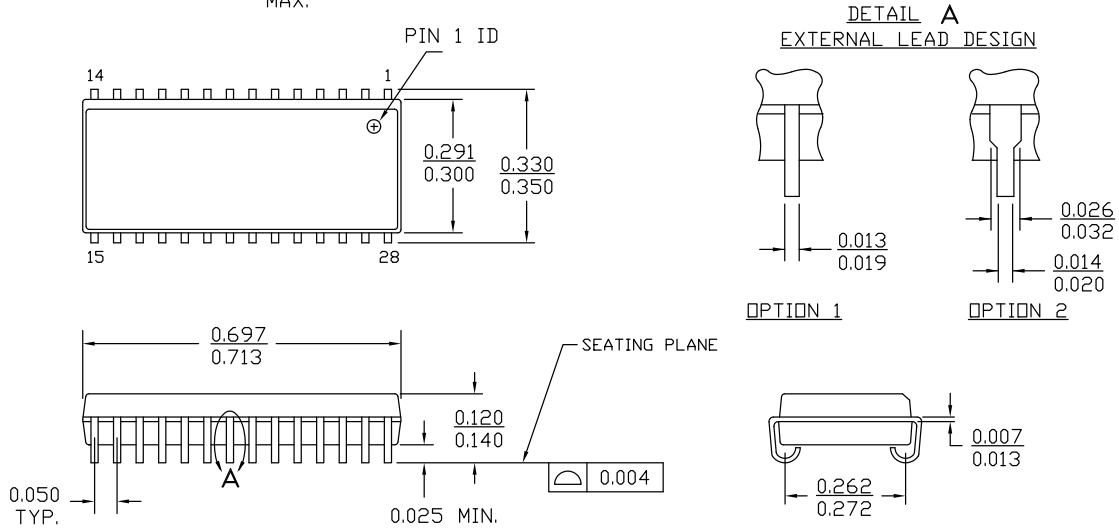

51-85031 *E

Acronyms

| Acronym | Description |
|---------|-----------------------------|
| DIP | dual in-line package |
| FIFO | first-in first-out |
| I/O | input/output |
| LCC | leadless chip carrier |
| PLCC | plastic leaded chip carrier |
| RAM | random access memory |
| SOJ | small outline J-lead |
| TQFP | thin quad flat pack |
| TTL | transistor-transistor logic |

Document Conventions

Units of Measure

| Symbol | Unit of Measure |
|--------|-----------------|
| °C | degree Celsius |
| MHz | megahertz |
| μA | microampere |
| mA | milliampere |
| mm | millimeter |
| mV | millivolt |
| ns | nanosecond |
| % | percent |
| pF | picofarad |
| V | volt |
| W | watt |

Document History Page

| Document Title: CY7C421, 512 × 9 Asynchronous FIFO | | | | |
|--|---------|-----------------|-----------------|--|
| Document Number: 38-06001 | | | | |
| Rev. | ECN No. | Orig. of Change | Submission Date | Description of Change |
| ** | 106462 | SZV | 07/11/01 | Change from Spec Number: 38-00079 to 38-06001 |
| *A | 122332 | RBI | 12/30/02 | Updated Maximum Ratings (Added power up requirements). |
| *B | 383597 | PCX | See ECN | Added Pb-Free Logo Updated Ordering Information (Added in Ordering Information: CY7C419-10JXC, CY7C419-15JXC, CY7C419-15VXC, CY7C421-10JXC, CY7C421-15AXC, CY7C421-20JXC, CY7C421-20VXC, CY7C425-10AXC, CY7C425-10JXC, CY7C425-15JXC, CY7C425-20JXC, CY7C425-20VXC, CY7C429-10AXC, CY7C429-15JXC, CY7C429-20JXC, CY7C433-10AXC, CY7C433-10JXC, CY7C433-15JXC, CY7C433-20AXC, CY7C433-20JXC). |
| *C | 2623658 | VKN / PYRS | 12/17/08 | Updated Ordering Information (Added CY7C421-20JXI, removed CY7C419/25/29/33 from the ordering information table). Removed 26-Lead CerDIP, 32-Lead RLCC, 28-Lead molded DIP packages from the data sheet Removed Military Information |
| *D | 2714768 | VKN / AESA | 06/04/2009 | Corrected defective Logic Block diagram, Pinouts, and Package diagrams |
| *E | 2896039 | RAME | 03/19/2010 | Added Contents. Updated Ordering Information (Removed inactive parts from the data sheet). Updated Package Diagrams . Updated links in Sales, Solutions, and Legal Information |
| *F | 3110157 | ADMU | 12/14/2010 | Added Ordering Code Definitions . |
| *G | 3324980 | ADMU | 07/26/2011 | Updated title to read as "CY7C421, 512 × 9 Asynchronous FIFO". Updated Features . Updated Functional Description (Removed information about CY7C420/424/425/428/429/432/433). Updated Selection Guide (Removed speed bins -10, -25, -30, -40 and -65). Updated Electrical Characteristics (Removed speed bins -10, -25, -30, -40 and -65). Updated Switching Characteristics (Removed speed bins -10, -25, -30, -40 and -65). Updated Architecture (Removed information about CY7C420/424/425/428/429/432/433). Updated Package Diagrams . Added Acronyms and Units of Measure . Updated in new template. |
| *H | 3697624 | SMCH | 08/07/2012 | Added Pin Definitions . Updated Architecture (Updated Reading Data from the FIFO (description)). |

Sales, Solutions, and Legal Information

Worldwide Sales and Design Support

Cypress maintains a worldwide network of offices, solution centers, manufacturer's representatives, and distributors. To find the office closest to you, visit us at [Cypress Locations](#).

Products

| | |
|--------------------------|--|
| Automotive | cypress.com/go/automotive |
| Clocks & Buffers | cypress.com/go/clocks |
| Interface | cypress.com/go/interface |
| Lighting & Power Control | cypress.com/go/powerpsoc cypress.com/go/plc |
| Memory | cypress.com/go/memory |
| Optical & Image Sensing | cypress.com/go/image |
| PSoC | cypress.com/go/psoc |
| Touch Sensing | cypress.com/go/touch |
| USB Controllers | cypress.com/go/USB |
| Wireless/RF | cypress.com/go/wireless |

PSoC Solutions

psoc.cypress.com/solutions
PSoC 1 | PSoC 3 | PSoC 5

© Cypress Semiconductor Corporation, 2001-2012. The information contained herein is subject to change without notice. Cypress Semiconductor Corporation assumes no responsibility for the use of any circuitry other than circuitry embodied in a Cypress product. Nor does it convey or imply any license under patent or other rights. Cypress products are not warranted nor intended to be used for medical, life support, life saving, critical control or safety applications, unless pursuant to an express written agreement with Cypress. Furthermore, Cypress does not authorize its products for use as critical components in life-support systems where a malfunction or failure may reasonably be expected to result in significant injury to the user. The inclusion of Cypress products in life-support systems application implies that the manufacturer assumes all risk of such use and in doing so indemnifies Cypress against all charges.

Any Source Code (software and/or firmware) is owned by Cypress Semiconductor Corporation (Cypress) and is protected by and subject to worldwide patent protection (United States and foreign), United States copyright laws and international treaty provisions. Cypress hereby grants to licensee a personal, non-exclusive, non-transferable license to copy, use, modify, create derivative works of, and compile the Cypress Source Code and derivative works for the sole purpose of creating custom software and or firmware in support of licensee product to be used only in conjunction with a Cypress integrated circuit as specified in the applicable agreement. Any reproduction, modification, translation, compilation, or representation of this Source Code except as specified above is prohibited without the express written permission of Cypress.

Disclaimer: CYPRESS MAKES NO WARRANTY OF ANY KIND, EXPRESS OR IMPLIED, WITH REGARD TO THIS MATERIAL, INCLUDING, BUT NOT LIMITED TO, THE IMPLIED WARRANTIES OF MERCHANTABILITY AND FITNESS FOR A PARTICULAR PURPOSE. Cypress reserves the right to make changes without further notice to the materials described herein. Cypress does not assume any liability arising out of the application or use of any product or circuit described herein. Cypress does not authorize its products for use as critical components in life-support systems where a malfunction or failure may reasonably be expected to result in significant injury to the user. The inclusion of Cypress' product in a life-support systems application implies that the manufacturer assumes all risk of such use and in doing so indemnifies Cypress against all charges.

Use may be limited by and subject to the applicable Cypress software license agreement.