

General Description

The AAT4687-1 OVPSwitch™ is a P-channel MOSFET power switch with precise over-voltage protection control, designed to protect low-voltage systems against high-voltage faults up to +28V. If the input voltage exceeds the fixed over-voltage threshold, the P-channel MOSFET switch will be turned off to prevent the output load circuits from damage. The AAT4687-1 is available with an internally programmed over-voltage trip point.

The AAT4687-1 includes an under-voltage lockout (UVLO) protection circuit, which will put the device into sleep mode at low input voltages only consuming < 1μA of current. The AAT4687-1 also includes an enable pin ($\overline{\text{EN}}$) to enable or disable the device and an Over-voltage protection (OVP), Over-temperature protection (OTP) fault indicator ($\overline{\text{FLT}}$).

The AAT4687-1 is offered in a small Pb-free, 10 pin SC70JW package, and is specified for operation over the -40°C to +85°C ambient temperature range.

Features

- Input Voltage Range up to 28V
- Over-voltage Protection Threshold
 - 5.9V Typical
 - 6V Maximum
- Fixed Over-voltage Protection Threshold
- 2V Typical Under-voltage Lockout Threshold
- Fast OVP Response:
 - 0.7μs Typical to Over-voltage Transient
- Low Operation Quiescent Current
 - 45μA Typical
 - 1μA Max in Shutdown (Disabled)
- Thermal Shutdown Protection
- 120mΩ Typical (140mΩ Max) $R_{\text{DS(ON)}}$ at 5V
- OVP, OTP Fault Indicator
- 1.8A Maximum Continuous Current
- Temperature Range: -40°C to 85°C
- Available in SC70JW-10 Package

Applications

- Cell Phones
- Digital Still Cameras
- GPS
- MP3 Players
- Personal Data Assistants (PDA)
- USB Hot Swap/Live Insertion Device

Typical Application

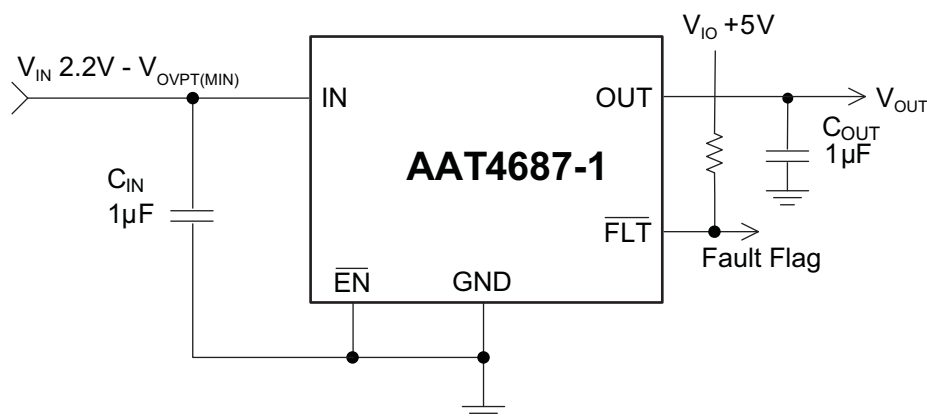

AAT4687-I

Over-Voltage Protection Switch

Pin Descriptions

Pin Number	Symbol	Function
1	N/C	No Connect.
2, 8, 9, 10	GND	Ground connection pin.
3	$\overline{\text{FLT}}$	Over-voltage or over-temperature fault reporting output pin. Open drain. $\overline{\text{FLT}}$ goes low when input voltage exceeds the over-voltage threshold or an over-temperature fault occurs. An external pull up resistor to V_{IO} (6.5V max) should be added.
4	$\overline{\text{EN}}$	Enable input pin, active low. An internal pull-down resistor is connected on this pin. Connect to ground for normal operation. Connect to high (6.5V max) to shut down the device, which then draws less than 1 μ A of current.
5	IN	Power input pin. Connect 1 μ F capacitor from IN to GND.
6, 7	OUT	Output. Connect a 0.1 μ F~47 μ F capacitor from OUT to GND.

Pin Configuration

SC70JW-10
(Top View)

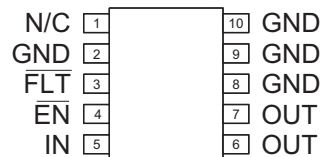

AAT4687-I**Over-Voltage Protection Switch****Absolute Maximum Ratings¹**

Symbol	Description	Value	Units
V_{IN}	IN to GND	-0.3 to 30	V
V_{OVP}	OVP to GND	-0.3 to 6.5	
V_{FLT}, V_{EN}	FLT, EN to GND	-0.3 to 6.5	
V_{OUT}	OUT to GND	-0.3 to $V_{IN} + 0.3$	
I_{MAX}	Maximum Continuous Switch Current	1.8	A
T_J	Operating Junction Temperature Range	-40 to 150	°C
T_{STG}	Storage Temperature	-40 to 150	
T_{LEAD}	Maximum Soldering Temperature (at Leads)	300	

Thermal Characteristics

Symbol	Description	Value	Units
Θ_{JA}	Maximum Thermal Resistance ²	160	°C/W
P_D	Maximum Power Dissipation ^{2, 3}	625	mW

1. Stresses above those listed in Absolute Maximum Ratings may cause permanent damage to the device. Functional operation at conditions other than the operating conditions specified is not implied.
2. Mounted on a FR4 board.
3. Derate 6.25mW/°C above 25°C.

DATA SHEET

AAT4687-I

Over-Voltage Protection Switch

Electrical Characteristics¹

$V_{IN} = 5V$, $T_A = -40$ to $85^\circ C$ unless otherwise noted. Typical values are at $T_A = 25^\circ C$.

Symbol	Description	Conditions	Min	Typ	Max	Units
V_{IN_MAX}	Input Over-voltage Protection Range				28	V
V_{IN}	Normal Operation Voltage Range		2.2		V_{OVP_MIN}	
I_Q	Operation Quiescent Current	$V_{IN} = 5V, \overline{EN} = 0V, I_{OUT} = 0$		35	60	μA
$I_{SD(OFF)}$	Shutdown Supply Current	$\overline{EN} = V_{IN}, V_{IN} = 5.5V, V_{OUT} = 0V$			1	
V_{UVLO}	Under-voltage Lockout Threshold	Rising Edge		2.0	2.2	V
V_{UVLO_HYS}	Under-voltage Lockout Threshold Hysteresis			0.1		
V_{OVPT}	Over-voltage Lockout Threshold, IN Pin	Rising Edge	5.7	5.9	6	
V_{OVP_HYS}	Over-Voltage Lockout Threshold Hysteresis, IN Pin			0.15		
MOSFET Switch						
$R_{DS(ON)}$	PMOS On-Resistance	$I_{OUT} = 1500mA^1, T_A = 25^\circ C$		120	140	$m\Omega$
$I_{D(OFF)}$	Switch Off-Leakage	$\overline{EN} = V_{IN}$			1	μA
Logic						
$V_{\overline{EN}(L)}$	\overline{EN} Input Low Voltage				0.4	V
$V_{\overline{EN}(H)}$	\overline{EN} Input High Voltage		1.6			V
$I_{\overline{EN}}$	\overline{EN} Input Leakage	$V_{\overline{EN}} = 5.5V$ or $0V$		0.5	2.0	μA
FLT_{OL}	FLT Output Voltage Low	$I_{FLT} = 1mA$			0.4	V
FLT_{IOL}	FLT Output Leakage Current				1	μA
Timing						
t_{BLK_FLT}	FLT Blanking Time	From De-assertion of OV	5	10	15	ms
t_{D_FLT}	FLT Assertion Delay Time from Over-voltage (OV)	From Assertion of OV		1		μs
t_{RLS_OV}	Over-voltage Release Time	V_{IN} fall from $6V + TBD$ to $V_{OVP(MIN)}$ - TBD	5	10	15	ms
t_{RESP_OV}	Over-voltage Response Time	V_{IN} rise from $V_{OVP(MIN)}$ - TBD to $6V + TBD$		0.7		μs
t_{ON}	Turn On Delay Time	$V_{IN} = 5V; R_{OUT} = 10\Omega; C_{OUT} = 1\mu F$		10		ms
t_R	Turn On Rise Time	$V_{IN} = 5V; R_{OUT} = 10\Omega; C_{OUT} = 1\mu F$		1		
t_{OFF}	Turn Off Delay Time	$V_{IN} = 5V; R_{OUT} = 10\Omega; C_{OUT} = 1\mu F$		9		
t_F	Turn Off Fall Time	$V_{IN} = 5V; R_{OUT} = 10\Omega; C_{OUT} = 1\mu F$		4.5		
Thermal Protection						
T_{SHDN}	Shutdown Temperature			150		$^\circ C$
T_{HYS}	Over-Temperature Shutdown Hysteresis			20		

1. Pulse test: pulse width = 300 μs

AAT4687-I

Over-Voltage Protection Switch

Timing Diagram

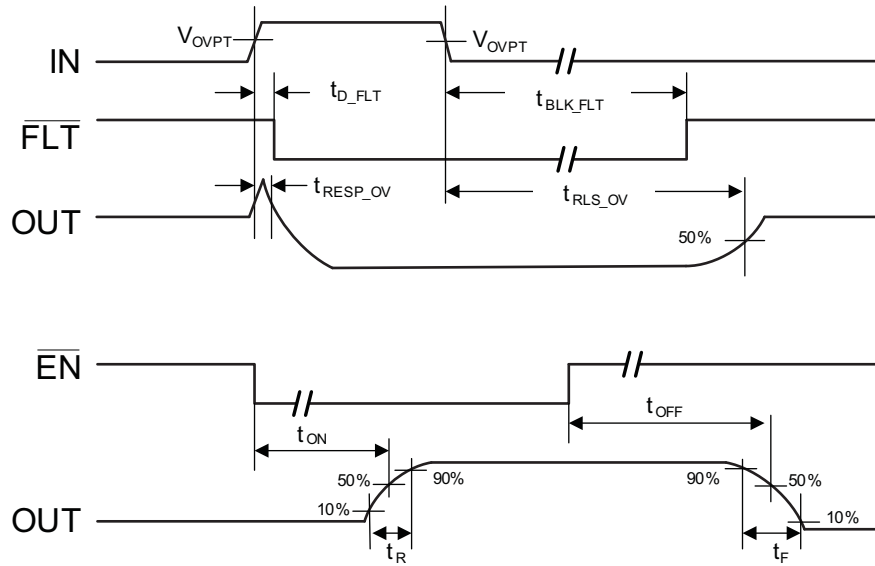

AAT4687-I

Over-Voltage Protection Switch

Operation Quiescent Current vs Supply Voltage

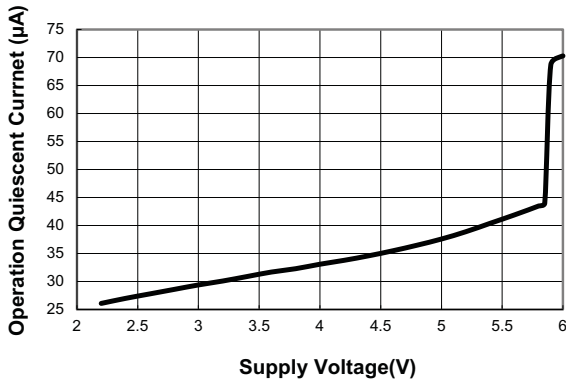

Operation Quiescent Current vs Temperature

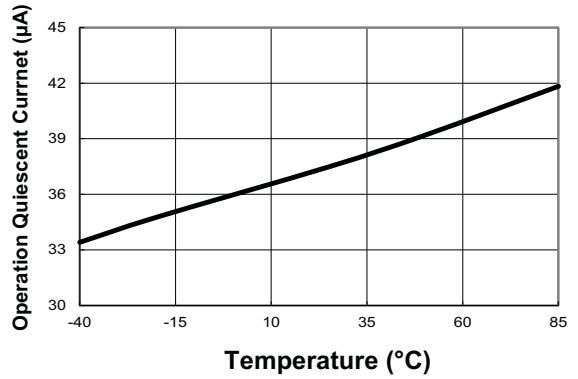

Shutdown Supply Current vs Supply Voltage

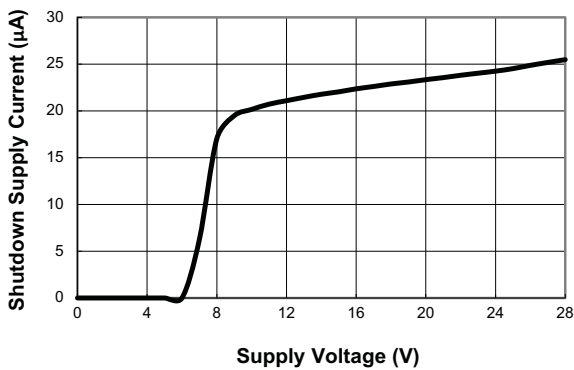

Switch Off Leakage vs Supply Voltage

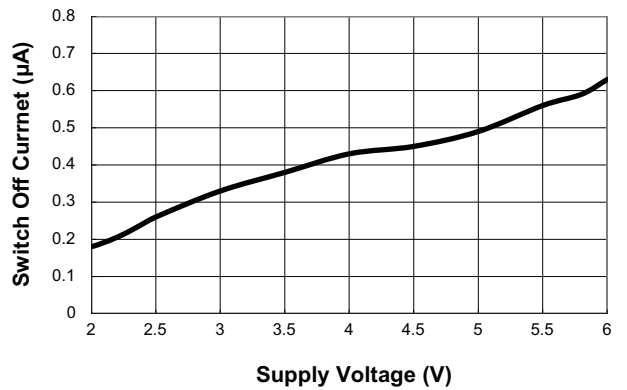

PMOS On-Resistance vs Temperature
($V_{IN} = 5V, I_{Load} = 1.5A$)

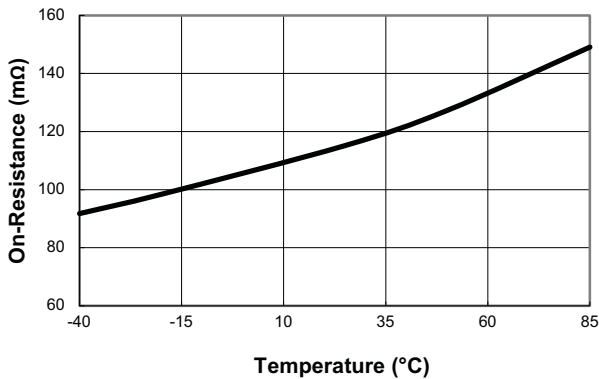

FLT Blanking Time ($V_{IN} = 5.0V$)

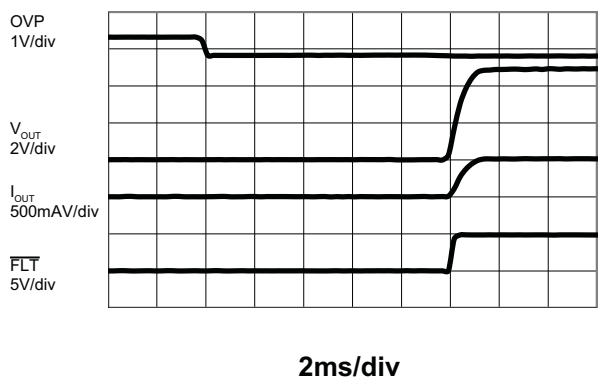

AAT4687-I

Over-Voltage Protection Switch

FLT Blanking Time vs Temperature

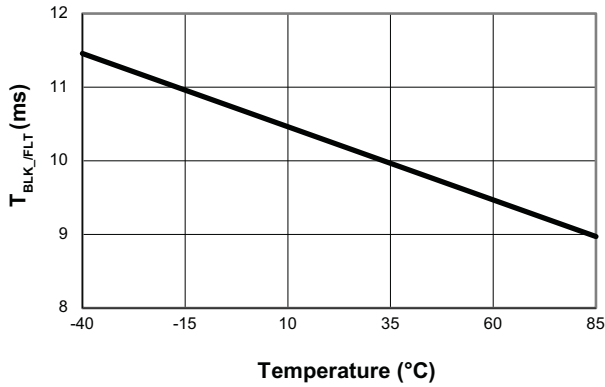

Under-Voltage Lockout Thresholds vs Temperature

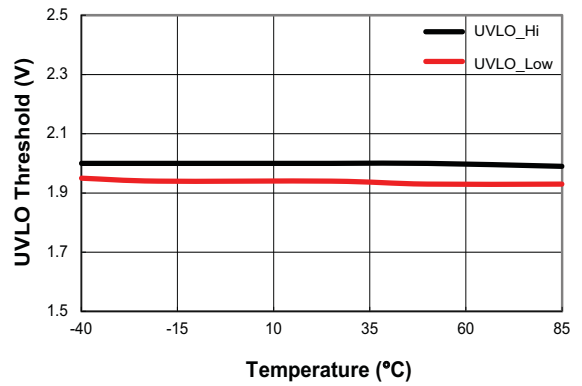

Over Voltage Response Time vs Temperature

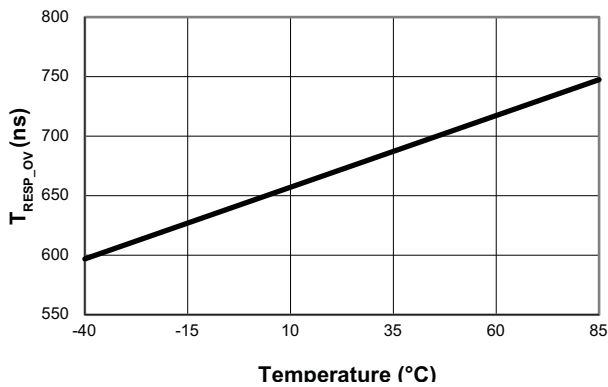

Over-Voltage Lockout Thresholds vs Temperature

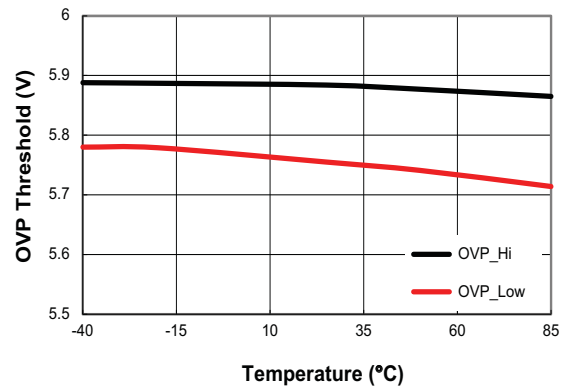

EN Input High Voltage vs Supply Voltage

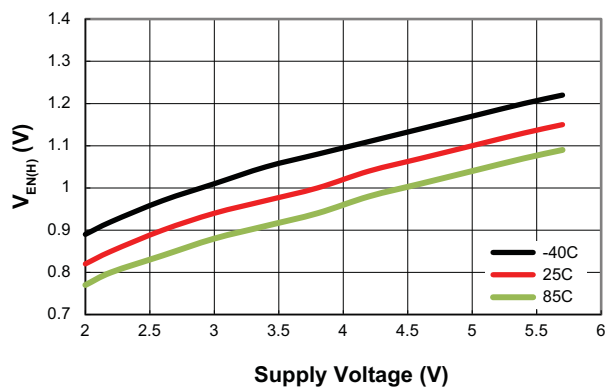

Over Voltage Release Time vs Temperature

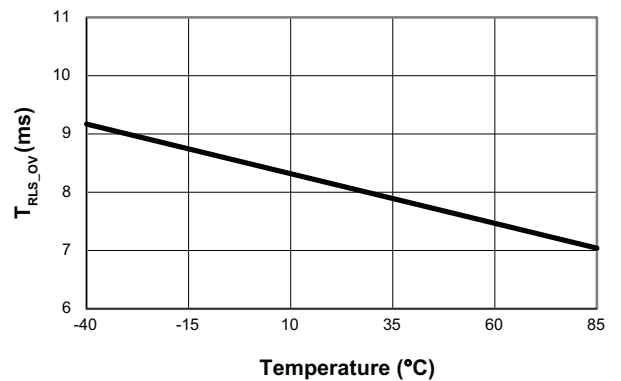

AAT4687-I

Over-Voltage Protection Switch

\overline{EN} Input High Voltage vs Supply Voltage

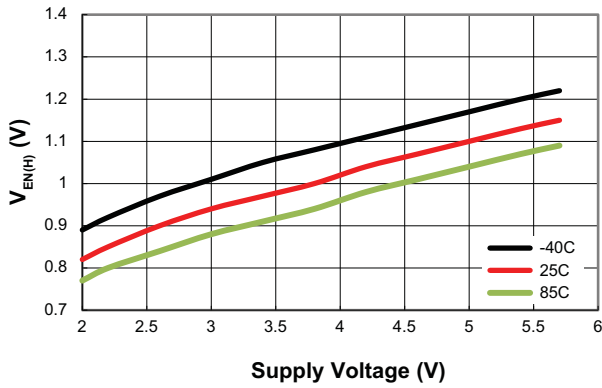

\overline{EN} Input Low Voltage vs Supply Voltage

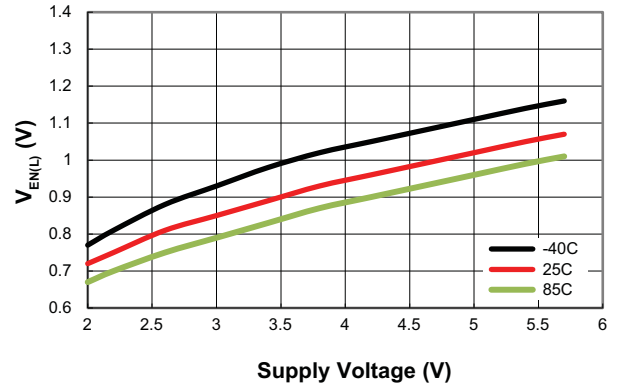

Turn On Delay Time ($V_{IN} = 5.0V, R_O = 10\Omega$)

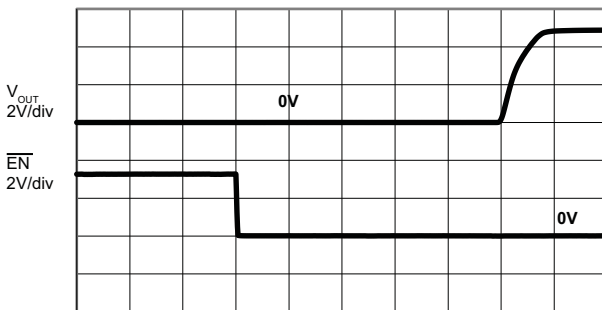

2ms/div

Turn Off Delay Time ($V_{IN} = 5.0V, R_O = 10\Omega$)

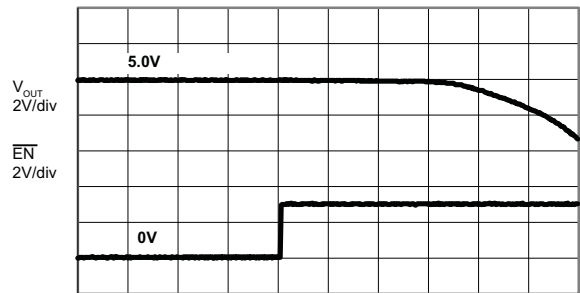

2ms/div

Over-Voltage Protection Response

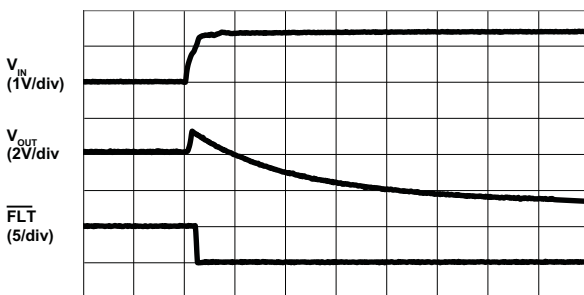

Time (5 μ s/div)

Over-Voltage Response Time

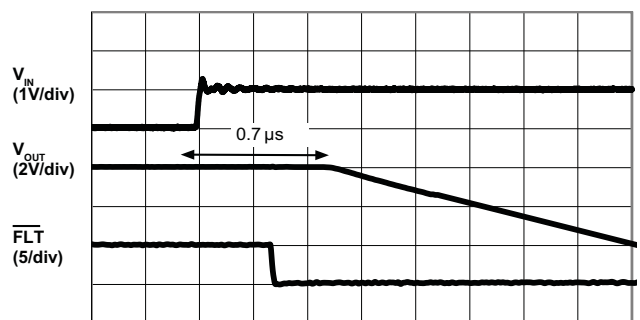

300ns/div

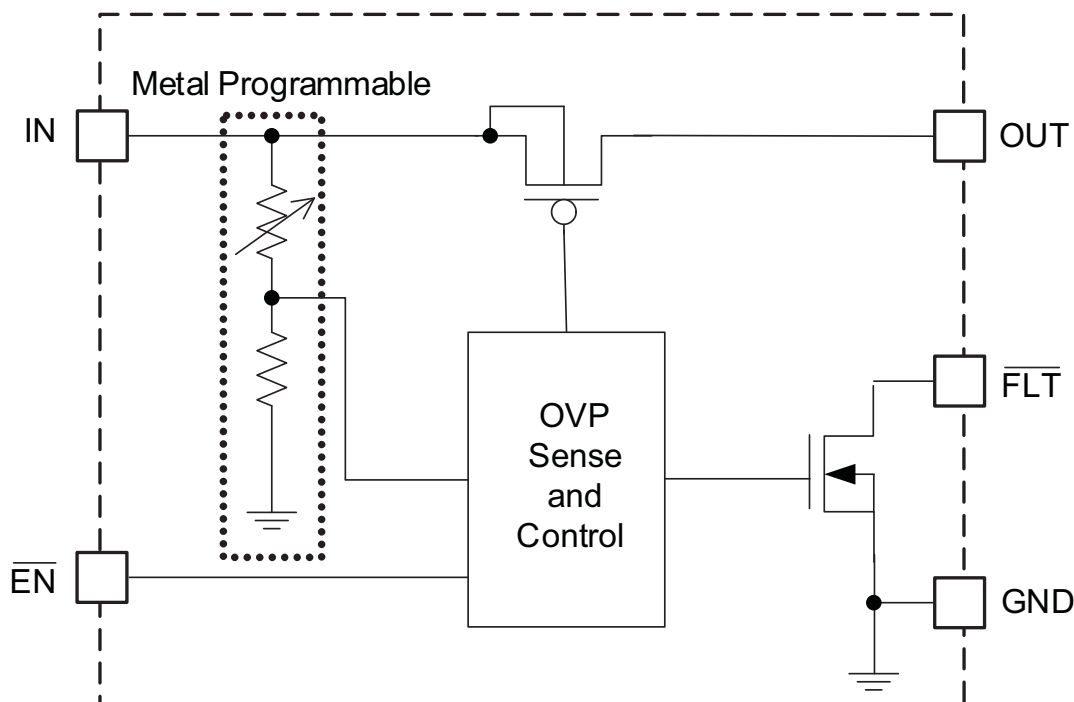
Functional Block Diagram**Functional Description**

The AAT4687-1 provides up to 5.9V over-voltage protection when powering low-voltage systems such as cell phones, MP3, and PDAs or when charging Lithium-Ion batteries from a poorly regulated supply. The AAT4687-1 is inserted between the power supply or charger source and the load to be protected. The AAT4687-1 IC includes a low resistance P-channel MOSFET, under-voltage lockout protection, over-voltage monitor, fast shut-down circuitry, and a fault output flag.

In normal operation the P-channel MOSFET acts as a slew-rate controlled load switch, connecting and disconnecting the power supply from IN to OUT. A low resistance MOSFET is used to minimize the voltage drop between the voltage source and the load and to reduce power dissipation. When the voltage on the input

exceeds the over-voltage protection trip voltage, set internally, the device immediately turns off the internal P-channel FET, disconnecting the load from the input and preventing damage to downstream components. Simultaneously, the fault flag is raised, alerting the system to a problem.

If an over-voltage condition is applied at the time of the device enable, then the switch will remain OFF.

Under-voltage Lockout (UVLO)

The AAT4687-1 has a fixed 2.0V under-voltage lockout level (UVLO). When the input voltage is less than the UVLO level, the MOSFET is turned off. 100mV of hysteresis is included to ensure circuit stability.

AAT4687-1

Over-Voltage Protection Switch

Over-voltage Protection (OVP)

The AAT4687-1 has a resistor divider which is internally integrated with the input voltage trip point at 5.9V. Once the over-voltage trip level is triggered, the PMOS switch controller will turn off the PMOS in less than 0.7 μ s.

Over-temperature Protection (OTP)

If the ambient temperature of the device exceeds T_{SHDN} , the OVP switch is turned off, and the pin is driven low. The OVP switch will recover automatically when the junction temperature falls below $T_{SHDN} - 20^{\circ}\text{C}$.

Fault Indicator ($\overline{\text{FLT}}$)

The output is an active-low open-drain fault reporting output. A pull-up resistor should be connected from $\overline{\text{FLT}}$ to the logic I/O voltage of the host system. $\overline{\text{FLT}}$ will be asserted immediately if an over-voltage or over-temperature fault occurs.

Enable Control ($\overline{\text{EN}}$)

$\overline{\text{EN}}$ is an active-low enable input. $\overline{\text{EN}}$ is driven low, connected to ground, or left floating for normal device operation. Taking the $\overline{\text{EN}}$ high turns off the MOSFET. In case of an over-voltage or UVLO condition, toggling the $\overline{\text{EN}}$ will not override the fault condition and the switch will remain off.

Device Operation

On initial power-up, if $V_{IN} < V_{UVLO}$ or if $V_{IN} > V_{OVP_TH}$ (5.9V), the PMOS is held off. If $V_{UVLO} < V_{IN}$, $V_{IN} < V_{OVP_TH}$, and $\overline{\text{EN}}$ is low, the device enters startup after a 10ms internal delay.

Application Information

Over-voltage Protection

The AAT4687-1 over-voltage protection circuit provides fast protection against transient voltage spikes and short duration spikes of high voltage from the power supply lines. The AAT4687-1 can quickly disconnect the input supply from the load and avoid damage to sensitive components.

In portable product applications, if the user removes the battery pack during charging, this action can create large transients and a high voltage spike can occur which can damage other electronic components in the product such as the battery charger. A "hot plug" of the AC/DC wall adapter into the AC outlet can create and release a voltage spike from the transformer. As a result, some sensitive components within the product can be damaged. With the AAT4687-1 placed between the power lines and the sensitive devices, they are insulated from the voltage spike and the input supply is disconnected in 0.7 μ s.

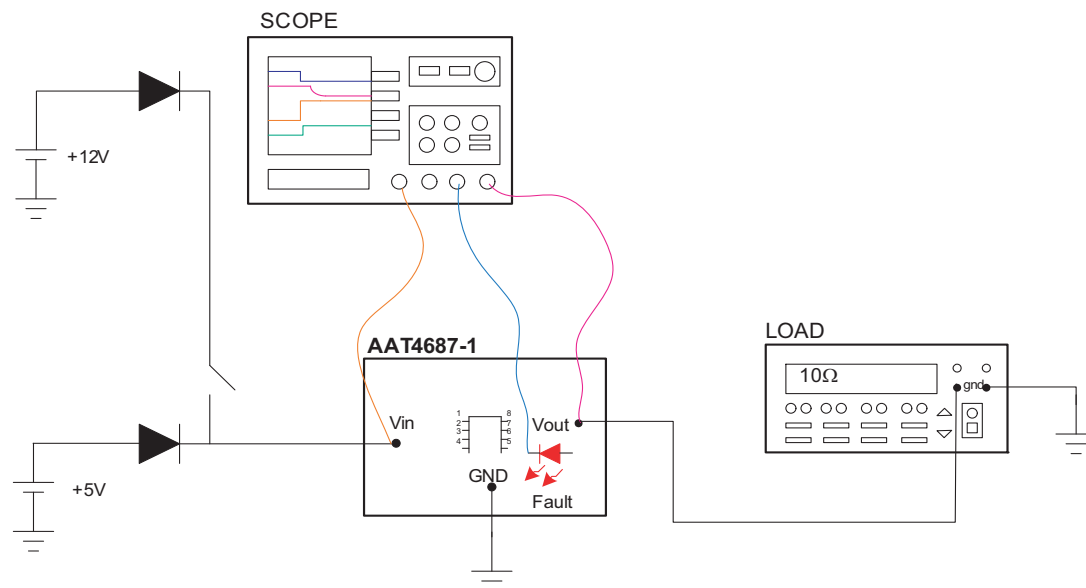

Figure 1: Over-Voltage Protection Response Time Test Circuit.

Over-Voltage Protection Switch

Input Capacitor

A 1μF or larger capacitor is typically recommended for C_{IN}. C_{IN} should be located as close to the device VIN pin as practically possible. Ceramic, tantalum, or aluminum electrolytic capacitors may be selected for C_{IN}. There is no specific capacitor equivalent series resistance (ESR) requirement for C_{IN}. However, for higher current operation, ceramic capacitors are recommended for C_{IN} due to their inherent capability over tantalum capacitors to withstand input current surges from low impedance sources such as batteries in portable devices.

Capacitors are typically manufactured in different voltage ratings. If the maximum possible surge voltage is known, select capacitors with a voltage rating at least 5V higher than the maximum possible surge voltage. Otherwise, 50V rated capacitors are generally good for most OVP applications to prevent any surge voltage.

Output Capacitor

A 0.1μF~47μF output capacitor is required at the output. Likewise, with the output capacitor, there is no specific capacitor ESR requirement. C_{OUT} may be increased to accommodate any load transient condition.

Thermal Considerations and Maximum Output Current

The AAT4687-1 delivers a continuous output load current. The limiting characteristic for maximum safe operating output load current is package power dissipation. In order to obtain high operating currents, careful device layout and circuit operating conditions must be taken into account. The following discussions will assume the load switch is mounted on a printed circuit board utilizing the minimum recommended footprint as stated in the "Printed Circuit Board Layout Recommendations" section of this datasheet. At any given ambient temperature (T_A), the maximum package power dissipation can be determined by the following equation:

$$P_{D(MAX)} = \frac{T_{J(MAX)} - T_A}{\theta_{JA}}$$

Constants for the AAT4687-1 are maximum junction temperature (T_{J(MAX)} = 125°C) and package thermal resistance (θ_{JA} = 160°C/W). Worst-case conditions are calculated at the maximum operating temperature, T_A = 85°C. Typical conditions are calculated under normal

ambient conditions where T_A = 25°C. At T_A = 85°C, P_{D(MAX)} = 250mW. At T_A = 25°C, P_{D(MAX)} = 625mW.

The maximum continuous output current for the AAT4687-1 is a function of the package power dissipation and the R_{DS} of the MOSFET at T_{J(MAX)}. The maximum R_{DS} of the MOSFET at T_{J(MAX)} is calculated by increasing the maximum room temperature.

For maximum current, refer to the following equation:

$$I_{OUT(MAX)} = \sqrt{\frac{P_{D(MAX)}}{R_{DS}}}$$

The maximum allowable output current for the AAT4687-1 is 1.8A. If the output current exceeds 1.8A, the device will be damaged.

Printed Circuit Board Layout Recommendations

For proper thermal management and to take advantage of the low R_{DS(ON)} of the AAT4687-1, certain circuit board layout rules should be followed: V_{IN} and V_{OUT} should be routed using wider than normal traces, and GND should be connected to a ground plane. To maximize package thermal dissipation and power handling capacity of the AAT4687-1 SC70JW-10 package, the ground plane area connected to the ground pins should be as large as possible. For best performance, C_{IN} and C_{OUT} should be placed close to the package pins, as shown in Figures 5 and 6.

AAT4687-I

Over-Voltage Protection Switch

Evaluation Board Schematic

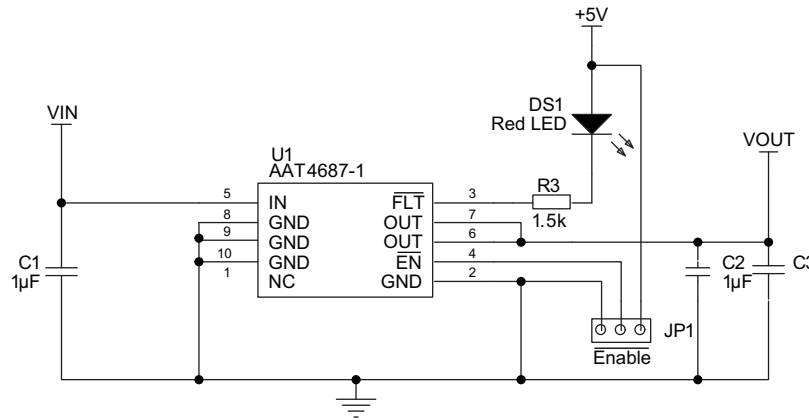

Figure 2: AAT4687-1 Evaluation Board Schematic.

Component	Part Number	Description	Manufacturer
U1	AAT4687-1	Over-voltage Protection Switch	Skyworks
R1		Not Populated	Yageo
R2		Not Populated	
R3	RC0603FR-071K5L	RES 1.5KΩ 1/10W 1% 0603 SMD	Murata
C1	GRM31MR71H105K	Cap Ceramic 1μF 1206 X7R 50V 10%	
C2	GRM21BR71C105K	Cap Ceramic 1μF 0805 X7R 16V 10%	HB
C3	Not populated		
D1	0805KRCT	Red LED 0805	

Table 2: AAT4687-1 Evaluation Board Bill of Materials.

Evaluation Board Layout

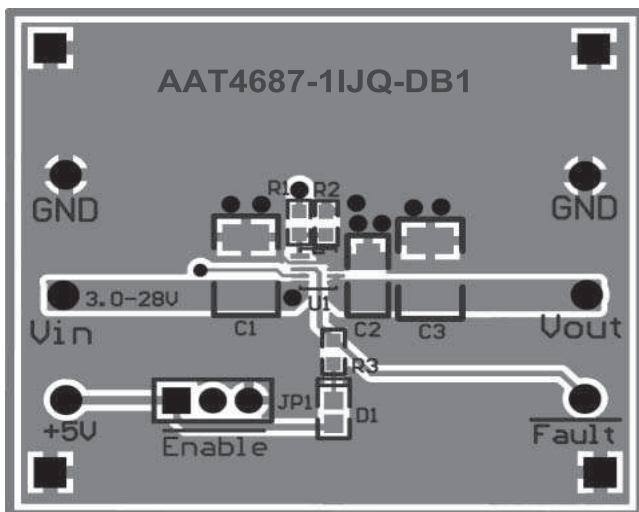

Figure 3: AAT4687-1 Evaluation Board Component Side Layout.

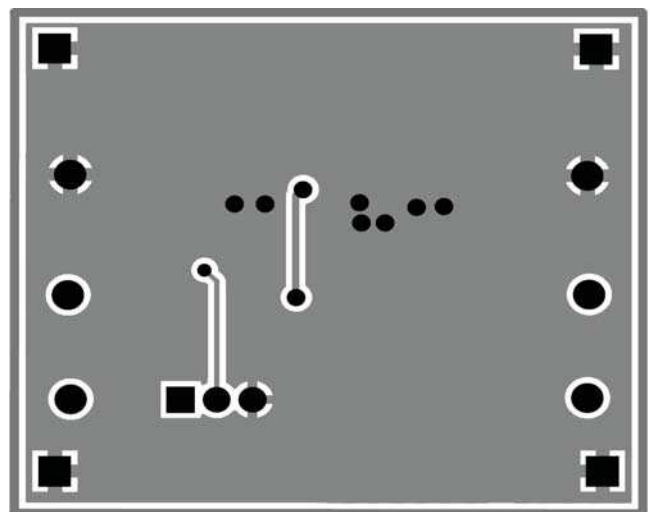

Figure 4: AAT4687-1 Evaluation Board Solder Side Layout.

Ordering Information

Package	Marking ¹	Part Number (Tape and Reel) ²
SC70JW-10	U2XYX	AAT4687I JQ-1-T1



Skyworks Green™ products are compliant with all applicable legislation and are halogen-free.

For additional information, refer to *Skyworks Definition of Green™*, document number SQ04-0074.

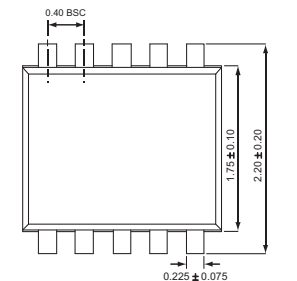
Package Information**SC70JW-10**

Top View

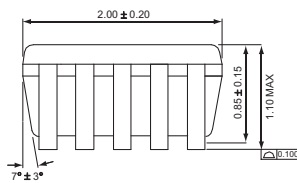

Side View

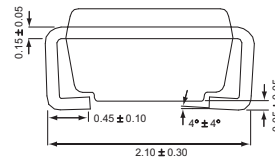

End View

All dimensions in millimeters.

1. XYY = assembly and date code.
2. Sample stock is generally held on part numbers listed in **BOLD**.

Copyright © 2012 Skyworks Solutions, Inc. All Rights Reserved.

Information in this document is provided in connection with Skyworks Solutions, Inc. ("Skyworks") products or services. These materials, including the information contained herein, are provided by Skyworks as a service to its customers and may be used for informational purposes only by the customer. Skyworks assumes no responsibility for errors or omissions in these materials or the information contained herein. Skyworks may change its documentation, products, services, specifications or product descriptions at any time, without notice. Skyworks makes no commitment to update the materials or information and shall have no responsibility whatsoever for conflicts, incompatibilities, or other difficulties arising from any future changes.

No license, whether express, implied, by estoppel or otherwise, is granted to any intellectual property rights by this document. Skyworks assumes no liability for any materials, products or information provided hereunder, including the sale, distribution, reproduction or use of Skyworks products, information or materials, except as may be provided in Skyworks Terms and Conditions of Sale.

THE MATERIALS, PRODUCTS AND INFORMATION ARE PROVIDED "AS IS" WITHOUT WARRANTY OF ANY KIND, WHETHER EXPRESS, IMPLIED, STATUTORY, OR OTHERWISE, INCLUDING FITNESS FOR A PARTICULAR PURPOSE OR USE, MERCHANTABILITY, PERFORMANCE, QUALITY OR NON-INFRINGEMENT OF ANY INTELLECTUAL PROPERTY RIGHT; ALL SUCH WARRANTIES ARE HEREBY EXPRESSLY DISCLAIMED. SKYWORKS DOES NOT WARRANT THE ACCURACY OR COMPLETENESS OF THE INFORMATION, TEXT, GRAPHICS OR OTHER ITEMS CONTAINED WITHIN THESE MATERIALS. SKYWORKS SHALL NOT BE LIABLE FOR ANY DAMAGES, INCLUDING BUT NOT LIMITED TO ANY SPECIAL, INDIRECT, INCIDENTAL, STATUTORY, OR CONSEQUENTIAL DAMAGES, INCLUDING WITHOUT LIMITATION, LOST REVENUES OR LOST PROFITS THAT MAY RESULT FROM THE USE OF THE MATERIALS OR INFORMATION, WHETHER OR NOT THE RECIPIENT OF MATERIALS HAS BEEN ADVISED OF THE POSSIBILITY OF SUCH DAMAGE.

Skyworks products are not intended for use in medical, lifesaving or life-sustaining applications, or other equipment in which the failure of the Skyworks products could lead to personal injury, death, physical or environmental damage. Skyworks customers using or selling Skyworks products for use in such applications do so at their own risk and agree to fully indemnify Skyworks for any damages resulting from such improper use or sale.

Customers are responsible for their products and applications using Skyworks products, which may deviate from published specifications as a result of design defects, errors, or operation of products outside of published parameters or design specifications. Customers should include design and operating safeguards to minimize these and other risks. Skyworks assumes no liability for applications assistance, customer product design, or damage to any equipment resulting from the use of Skyworks products outside of stated published specifications or parameters.

Skyworks, the Skyworks symbol, and "Breakthrough Simplicity" are trademarks or registered trademarks of Skyworks Solutions, Inc., in the United States and other countries. Third-party brands and names are for identification purposes only, and are the property of their respective owners. Additional information, including relevant terms and conditions, posted at www.skyworksinc.com, are incorporated by reference.