

Absolute encoders - parallel

Shaft with clamping or synchro flange

Optical multiturn encoders 12 bit ST / 12 bit MT

GXP1W - parallel



GXP1W with clamping flange

Features

- Encoder multiturn / parallel
- Optical sensing
- Resolution: singleturn 12 bit, multiturn 12 bit
- Clamping or synchro flange
- Resolution, code and preset programmable
- Encoder programming by Windows software
- RS232 encoder programming interface

Technical data - electrical ratings

Voltage supply	10...30 VDC
Reverse polarity protection	Yes
Consumption w/o load	≤50 mA (24 VDC)
Initializing time (typ.)	50 ms after power on
Interface	24 parallel outputs
Function	Multiturn
Steps per turn	≤4096 / 12 bit
Number of turns	≤4096 / 12 bit
Absolute accuracy	±0.03 °
Sensing method	Optical
Code	Gray, cut gray, BCD, binary programmable
Code sequence	CW/CCW coded and programmable by connection
Inputs	TxD, RxD (RS232) Control signals UP/DOWN and zero ENABLE STORE
Output circuit	PNP or NPN open collector
Interference immunity	DIN EN 61000-6-2
Emitted interference	DIN EN 61000-6-4
Programming interface	RS232
Programmable parameters	Steps per revolution Number of revolutions Code 2 presets (limits) Rotation speed monitoring
Diagnostic functions	Self-diagnosis Code continuity check Multiturn sensing
Approval	UL approval / E63076

Technical data - mechanical design

Dimensions (flange)	ø58 mm
Shaft	ø10 mm (clamping flange) ø6 mm (synchro flange)
Flange	Clamping or synchro flange
Protection DIN EN 60529	IP 54 (without shaft seal), IP 65 (with shaft seal)
Operating speed	≤10000 rpm (mechanical) ≤6000 rpm (electric)
Starting torque	≤0.015 Nm (IP 54) ≤0.03 Nm (IP 65)
Rotor moment of inertia	20 gcm ²
Shaft loading	≤20 N axial ≤40 N radial
Materials	Housing: steel Flange: aluminium
Operating temperature	-25...+70 °C
Relative humidity	95 % non-condensing
Resistance	DIN EN 60068-2-6 Vibration 10 g, 16-2000 Hz DIN EN 60068-2-27 Shock 200 g, 6 ms
Weight approx.	600 g
Connection	Cable 1 m, connector D-SUB, 37-pin

Absolute encoders - parallel

Shaft with clamping or synchro flange

Optical multiturn encoders 12 bit ST / 12 bit MT

GXP1W - parallel

Part number

GXP1W. **C1**

		Connection
	31	Cable 1 m, axial, connector D-SUB, 37-pin
	41	Cable 1 m, radial, connector D-SUB, 37-pin
		Voltage supply / signals
	10	10...30 VDC / open collector NPN
	20	10...30 VDC / open collector PNP
		Flange / Shaft
	0	Clamping flange / ø10 mm IP 54
	A	Clamping flange / ø10 mm IP 65
	1	Synchro flange / ø6 mm IP 54
	B	Synchro flange / ø6 mm IP 65

Accessories

Connectors and cables

Z 140.001 Female connector D-SUB, 37-pin

Mounting accessories

Z 119.006 Eccentric fixing, single

Z 119.013 Adaptor plate for clamping flange for modification into synchro flange

Z 119.015 Mounting adaptor for synchro flange

Z 119.017 Mounting angle for clamping flange (M3)

Z 119.035 Bearing flange for encoders with synchro flange

Programming accessories

Z 139.005 Programming cable for parallel shaft encoders, CD with ProGeber software and manual

Z 150.008 CD with software ProGeber & manual

Data transfer

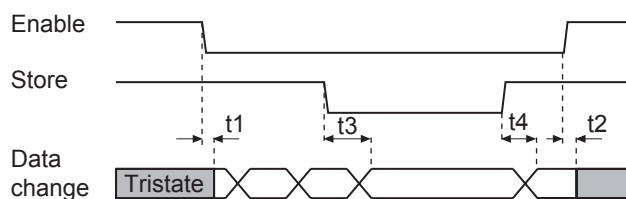

Signal form	Typ. pul time	Time
Enable	t1/t2	60 µs
Store	t3/t4	200 µs

Absolute encoders - parallel

Shaft with clamping or synchro flange

Optical multiturn encoders 12 bit ST / 12 bit MT

GXP1W - parallel

Terminal significance	
UB	Encoder voltage supply.
GND	Encoder ground connection relating to UB.
Outputs D0-D23	24 parallel output signals. For PNP it is recommended to utilize pull-down resistors for every data line, for NPN pull-up resistors of 4.7 kΩ.
Outputs D19 - D23	Special outputs With inferior resolutions these outputs may be configured as special outputs.
Zero setting	Input for setting a zero point anywhere within the programmed encoder resolution. The zero setting operation is triggered by a High impulse and has to be in line with the selected direction of rotation (UP/DOWN). Connect to GND after setting operation for maximum interference immunity. Impulse duration ≥ 100 ms. If there is an offset being entered by programming interface the offset will be activated by the zero input.
UP/DOWN	UP/DOWN counting direction input. This input is standard on High. UP/DOWN means ascending output data with clockwise shaft rotation when looking at flange. UP/DOWN-Low means ascending values with counterclockwise shaft rotation when looking at flange.
ENABLE	Input for activating the output drivers that are triggered by input level Low. Upon being on High (or less potential) the output drivers switch to high-impedance (Tristate).
STORE	Input for output data storage. Upon a Low input level the encoder data are stored in the intermediate memory. Upon being on High (or less potential) the current encoder position data are switched to the output drivers. This line must be applied for reliable data readout in binary code.
GND-Sense	Internally connected to GND and serves together with UB-Sense for measuring the encoder voltage supply.
UB-Sense	Internally connected to UB. In case the sensor line is not utilized the connection must be isolated (danger of short circuit).

Terminal assignment		
Connector	Core colour	Assignment
Pin 1	white	Output D0
Pin 2	brown	Output D1
Pin 3	green	Output D2
Pin 4	yellow	Output D3
Pin 5	grey	Output D4
Pin 6	pink	Output D5
Pin 7	black	Output D6
Pin 8	violet	Output D7
Pin 9	grey/pink	Output D8
Pin 10	red/blue	Output D9
Pin 11	white/green	Output D10
Pin 12	brown/green	Output D11
Pin 13	white/yellow	Output D12
Pin 14	yellow/brown	Output D13
Pin 15	white/grey	Output D14
Pin 16	grey/brown	Output D15
Pin 17	white/pink	Output D16
Pin 18	pink/brown	Output D17
Pin 19	white/black	Output D18
Pin 20	brown/black	Output D19
Pin 21	grey/green	Output D20
Pin 22	yellow/grey	Output D21
Pin 23	pink/green	Output D22
Pin 24	yellow/pink	Output D23
Pin 25	–	–
Pin 26	–	–
Pin 27	yellow/blue	Zero setting
Pin 28	brown/blue	ENABLE
Pin 29	brown/red	STORE
Pin 30	green/blue	UP/DOWN
Pin 31	–	–
Pin 32	–	–
Pin 33	–	–
Pin 34	white/blue	GND-Sense
Pin 35	white/red	UB-Sense
Pin 36	red	UB
Pin 37	blue	GND

Absolute encoders - parallel

Shaft with clamping or synchro flange

Optical multiturn encoders 12 bit ST / 12 bit MT

GXP1W - parallel

Terminal assignment programming cable

Encoder function	Mating connector M12, 5-pins	PC connector D-SUB, 9-pins
-	Pin 1	-
RxD	Pin 2	Pin 3
GND	Pin 3	Pin 5
TxD	Pin 5	Pin 2
		Jumper 4-6 and Jumper 7-8

Connect encoder to voltage supply (UB/red/pin 36 and GND/blue/pin 37) using the supplementary 37-pin D-SUB connector.

Trigger level

Control inputs	Input circuit
Input level High	>0.7 UB
Input level Low	<0.3 UB
Input resistance	10 kΩ
Parallel outputs	Output circuit
	Open collector circuit-proof
Output level High (PNP)	>UB -4.5 V (I = -15 mA)
Output level Low (NPN)	<3.5 V (I = 15 mA)
Load High (PNP)	<-20 mA
Load Low (NPN)	<20 mA
Tristate	<200 μA

Dimensions

GXP1W - clamping flange

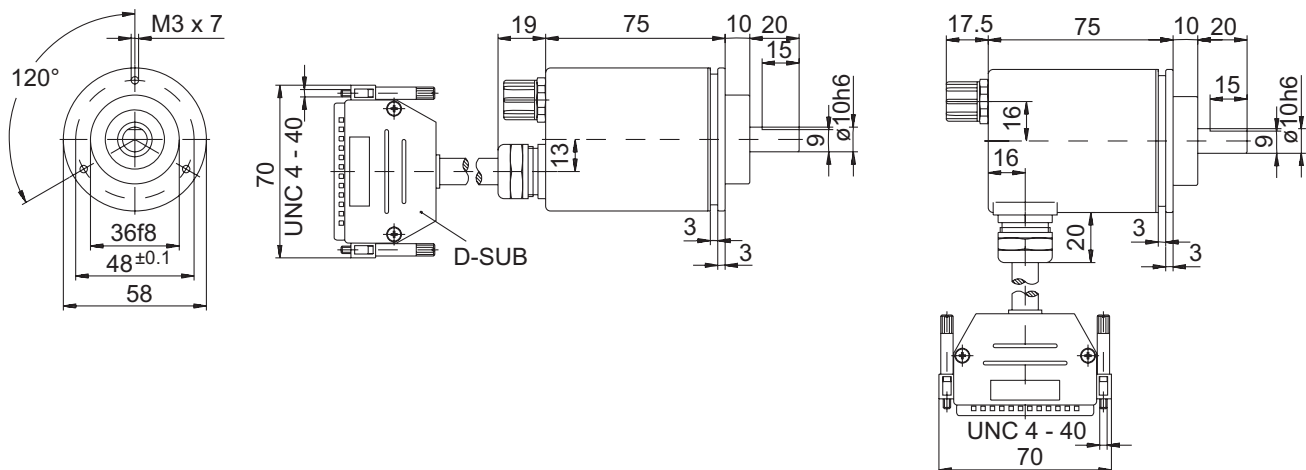

GXP1W - synchro flange

