

# Inclination sensors

Measuring range  $\pm 15^\circ$ ,  $\pm 30^\circ$ ,  $\pm 60^\circ$ ,  $360^\circ$

CANopen / Profibus-DP

## GNAMG



GNAMG with mounting plate 99 x 60 mm

### Technical data - electrical ratings

Voltage supply	10...30 VDC
Reverse polarity protection	Yes
Consumption w/o load	$\leq 100$ mA (24 VDC)
Initializing time (typ.)	250 ms after power on
Interfaces	CANopen, Profibus-DP V0
User address	Rotary switch in bus cover
Measuring range	$\pm 15^\circ/\pm 30^\circ/\pm 60^\circ$ (two-dimensional) $360^\circ$ (one-dimensional)
Resolution	0.001..1 ° (measuring range 15°, 30°, 60°) 0.1..1 ° (measuring range 360°)
Accuracy (+25 °C)	$\pm 0.1^\circ$ (measuring range 15°) $\pm 0.2^\circ$ (measuring range 30°, 60°, 360°)
Build-up time max.	0.5 s
Measuring cycle	10 Hz
Code	Binary
Interference immunity	DIN EN 61000-6-2
Emitted interference	DIN EN 61000-6-4
Programmable parameters	Resolution Preset and offset
Diagnostic function	Parameter error
Status indicator	DUO-LED integrated in bus cover
Approval	UL approval / E63076

### Features

- Inclination sensor / CANopen / Profibus
- Measuring range two-dimensional:  $\pm 15^\circ$ ,  $\pm 30^\circ$ ,  $\pm 60^\circ$
- Measuring range one-dimensional:  $360^\circ$
- Resolution: 0.001° to 1°
- Accuracy:  $\pm 0.1^\circ$  to 0.2°
- Programmable parameters
- Protection max. IP 67

### Optional

- Stainless steel

### Technical data - mechanical design

Dimensions mounting plate	99 x 60 x 5 mm
Protection DIN EN 60529	IP 66 (connector M12), IP 67 (cable gland)
Materials	Bus cover: zinc die-cast Base plate: aluminium
Operating temperature	-25...+85 °C -40...+85 °C (optional: only cable gland)
Relative humidity	95 % non-condensing
Resistance	DIN EN 60068-2-6 Vibration 10 g, 16-2000 Hz DIN EN 60068-2-27 Shock 200 g, 6 ms
Weight approx.	250 g
Connection	Cable gland Connector M12, 4-pin Connector M12, 5-pin

# Inclination sensors

Measuring range  $\pm 15^\circ$ ,  $\pm 30^\circ$ ,  $\pm 60^\circ$ ,  $360^\circ$   
CANopen / Profibus-DP

GNAMG

## Part number

GNAMG. 0

		<u>Interface</u>
	5P32	CANopen / cable gland
	5PA2	CANopen / connector M12
	3P32	Profibus-DPV0 / cable gland
	3PA2	Profibus-DPV0 / connector M12
		<u>Measuring range</u>
	21	Dual axes $\pm 15^\circ$
	22	Dual axes $\pm 30^\circ$
	23	Dual axes $\pm 60^\circ$
	15	Single axis $360^\circ$ (no end stop)
		<u>Housing</u>
0		Bus cover with mounting plate 99 x 60 mm

CD with file descriptions is not included in the delivery. You may order them on CD as accessory free-of-charge.

## Accessories

### Connectors and cables

Z 180.005	Female connector M12, 5-pin, A-coded, 5 m cable
Z 180.007	Female connector M12, 5-pin, A-coded, 10 m cable
Z 181.005	Cable connector M12, 5-pin, A-coded, 5 m cable, CANopen, connection continuative bus

### Programming accessories

Z 150.022	CD with describing files & manuals
-----------	------------------------------------

## Terminal assignment

### CANopen – M12 connector, assignment 1

Connector Assignment	Description
Pin 1	GND Ground connection relating to UB
Pin 2	UB Voltage supply 10...30 VDC
Pin 3	–
Pin 4	CAN_H CAN bus signal (dominant High)
Pin 5	CAN_L CAN bus signal (dominant Low)

### CANopen – M12 connector, assignment 2

Connector Assignment	Description
Pin 1	Drain
Pin 2	UB Voltage supply 10...30 VDC
Pin 3	GND Ground connection relating to UB
Pin 4	CAN_H CAN bus signal (dominant High)
Pin 5	CAN_L CAN bus signal (dominant Low)

M12 connector (male / female)  
A-coded

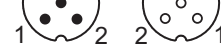

### Profibus – M12 connector

Pin 1	UB	Voltage supply 10...30 VDC
Pin 3	GND	Ground connection relating to UB

M12 connector (male)  
A-coded



Pin 2 A Negative data line

Pin 4 B Positive data line

M12 connector (male / female)  
B-coded

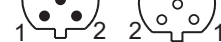

Terminals of the same significance are internally connected and identical in their functions. Max. load on the internal terminal connections UB-UB and GND-GND is 1 A each.

# Inclination sensors

Measuring range  $\pm 15^\circ$ ,  $\pm 30^\circ$ ,  $\pm 60^\circ$ ,  $360^\circ$

CANopen / Profibus-DP

## GNAMG

### Installation position

#### Measuring range $15^\circ$ , $30^\circ$ , $60^\circ$



The two-dimensional inclination sensor with a configured range of  $15^\circ$ ,  $30^\circ$  and  $60^\circ$  must be mounted with the base plate in horizontal position, i.e. parallel to the horizontal line. The inclination sensor may also be installed upside down, i.e. turned by  $180^\circ$ .

The sensor can be inclined both towards the X and Y axis at the same time. For each axis a separate measured value is provided. Default on delivery the inclination sensor will apply the selected sensing range to both axis, for example  $\pm 15^\circ$  with the zero passage being precisely in the horizontal line.



Default  $0^\circ$



Measured inclination  $-30^\circ$



Default  $0^\circ$



Measured inclination  $30^\circ$

#### Measuring range $360^\circ$

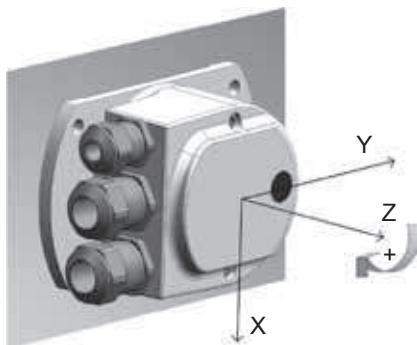

The inclination sensor with a configured range of  $360^\circ$  must be mounted in a way that the X-axis as in the following sketch is directed in a parallel way towards gravity. The deflection may not be more than  $\pm 3^\circ$ .

Please note also that the inclination sensor must evenly touch the contact surface and during inclination/rotation must not be subject to any inclination in X- or Y-direction since this would have a negative impact on the measuring accuracy.

The  $360^\circ$  inclination sensor default position is  $0^\circ$  as shown in the following illustration but may be configured at will by help of the preset function. The measuring direction may also be inverted. Default on delivery the inclination sensor's sensing direction is clockwise from  $0 \dots 360^\circ$ , in case of active inversion counter-clockwise.



Default  $0^\circ$

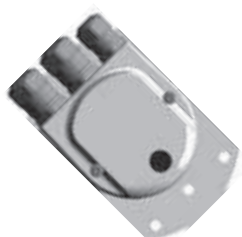

Measured inclination  $45^\circ$

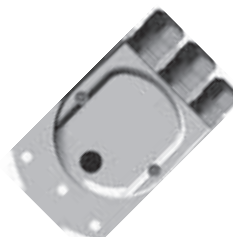

Measured inclination  $135^\circ$



Measured inclination  $180^\circ$

# Inclination sensors

Measuring range  $\pm 15^\circ$ ,  $\pm 30^\circ$ ,  $\pm 60^\circ$ ,  $360^\circ$   
CANopen / Profibus-DP

**GNAMG**

## Dimensions

### GNAMG - cable gland

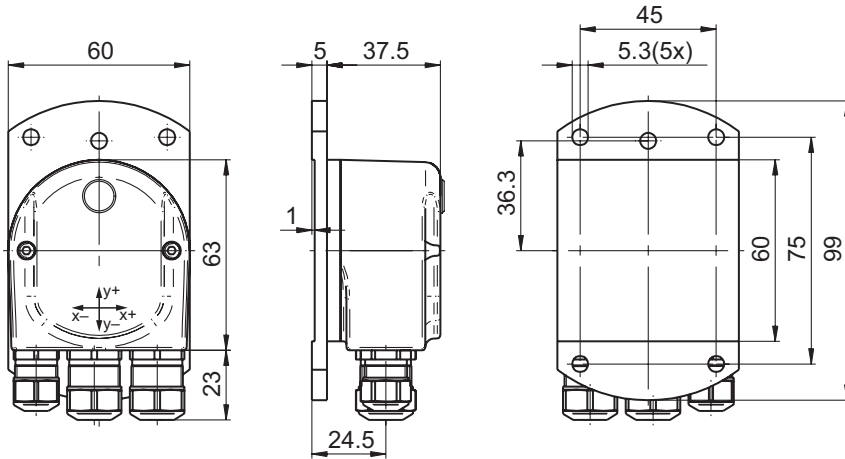

### CANopen - M12

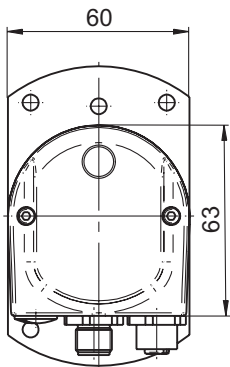

### Profibus connector M12

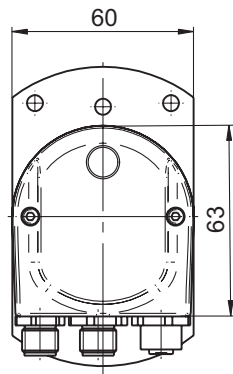

### Mounting version

