

Absolute encoders - parallel

Shaft with clamping or synchro flange

Optical singleturn encoders 10 bit, gray or binary

GA210, GA211 - parallel



GA210 with clamping flange

Features

- Encoder singleturn / parallel
- Optical sensing
- Resolution: 10 bit
- Clamping or synchro flange
- Low-cost encoder
- Short-circuit proof push-pull outputs
- Output release by enable signal
- Extreme compact design
- Reset input

Technical data - electrical ratings

Voltage supply	10...30 VDC
Reverse polarity protection	Yes
Consumption w/o load	≤60 mA (24 VDC)
Initializing time (typ.)	20 ms after power on
Interface	10 parallel outputs
Function	Singleturn
Steps per turn	1024 / 10 bit
Absolute accuracy	±0.1 °
Sensing method	Optical
Code	Gray or binary
Code sequence	CW/CCW coded by connection
Inputs	Control signals UP/ <u>DOWN</u> and zero <u>STORE</u> <u>ENABLE</u>
Output circuit	Push-pull short-circuit proof
Interference immunity	DIN EN 61000-6-2
Emitted interference	DIN EN 61000-6-4
Approval	UL approval / E63076

Technical data - mechanical design

Dimensions (flange)	ø58 mm
Protection DIN EN 60529	IP 54 (without shaft seal), IP 65 (with shaft seal)
Operating speed	≤10000 rpm (mechanical) ≤6000 rpm (electric)
Starting torque	≤0.015 Nm (IP 54) ≤0.03 Nm (IP 65)
Rotor moment of inertia	14.5 gcm ²
Shaft loading	≤20 N axial ≤40 N radial
Materials	Housing: aluminium Flange: aluminium
Operating temperature	-25...+85 °C -40...+85 °C (optional)
Relative humidity	95 % non-condensing
Resistance	DIN EN 60068-2-6 Vibration 10 g, 16-2000 Hz DIN EN 60068-2-27 Shock 200 g, 6 ms
Weight approx.	250 g
Connection	Connector M23, 16-pin Cable 1 m

GA210

Shaft	ø10 mm
Flange	Clamping flange

GA211

Shaft	ø6 mm
Flange	Synchro flange

Absolute encoders - parallel

Shaft with clamping or synchro flange

Optical singleturn encoders 10 bit, gray or binary

GA210, GA211 - parallel

Part number

Clamping flange

GA210. **05**

	<u>Connection</u>
B0	Connector M23, 16-pin, axial
B1	Connector M23, 16-pin, radial
11	Cable 1 m, axial
21	Cable 1 m, radial
	<u>Voltage supply / signals</u>
10	10...30 VDC / gray code push-pull
12	10...30 VDC / binary code push-pull
	<u>Flange / Shaft</u>
0	Clamping flange / ø10 mm IP 54
A	Clamping flange / ø10 mm IP 65

Synchro flange

GA211. **05**

	<u>Connection</u>
B0	Connector M23, 16-pin, axial
B1	Connector M23, 16-pin, radial
11	Cable 1 m, axial
21	Cable 1 m, radial
	<u>Voltage supply / signals</u>
10	10...30 VDC / gray code push-pull
12	10...30 VDC / binary code push-pull
	<u>Flange / Shaft</u>
1	Synchro flange / ø6 mm IP 54
B	Synchro flange / ø6 mm IP 65

Data transfer

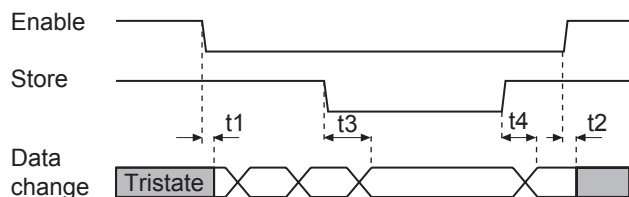

Signal form	Typ. pul time	Time
Enable	t1/t2	60 µs
Store	t3/t4	60 µs

Accessories

Connectors and cables

Z 131.001	Female connector M23, 16-pin, less cable
Z 131.003	Female connector M23, 16-pin, 2 m cable
Z 131.005	Female connector M23, 16-pin, 5 m cable
Z 131.007	Female connector M23, 16-pin, 10 m cable

Mounting accessories for GA210

Z 119.013	Adaptor plate for clamping flange for modification into synchro flange
Z 119.017	Mounting angle for clamping flange (M3)

Mounting accessories for GA211

Z 119.006	Eccentric fixing, single
Z 119.015	Mounting adaptor for synchro flange
Z 119.035	Bearing flange for encoders with synchro flange

Absolute encoders - parallel

Shaft with clamping or synchro flange

Optical singleturn encoders 10 bit, gray or binary

GA210, GA211 - parallel

Terminal significance	
UB	Encoder voltage supply.
GND	Encoder ground connection relating to UB.
Outputs D0-D9	10 parallel output signals.
Zero setting	Input for setting a zero point anywhere within the programmed encoder resolution. The zero setting operation is triggered by a High impulse and has to be in line with the selected direction of rotation (UP/DOWN). Connect to GND after setting operation for maximum interference immunity. Impulse duration >100 ms.
UP/DOWN	UP/DOWN counting direction input. This input is standard on High. UP/DOWN means ascending output data with clockwise shaft rotation when looking at flange. UP/DOWN-Low means ascending values with counterclockwise shaft rotation when looking at flange.
ENABLE	Input for activating the output drivers that are triggered by input level Low. Upon being on High (or less potential) the output drivers switch to high-impedance (Tristate).
STORE	Input for output data storage. Upon a Low input level the encoder data are stored in the intermediate memory. Upon being on High (or less potential) the current encoder position data are switched to the output drivers. This line must be applied for reliable data readout in binary code.

Terminal assignment		
Connector	Core colour	Assignment
Pin 1	violet	Output D0
Pin 2	white/brown	Output D1
Pin 3	white/green	Output D2
Pin 4	white/yellow	Output D3
Pin 5	white/grey	Output D4
Pin 6	white/pink	Output D5
Pin 7	white/blue	Output D6
Pin 8	white/red	Output D7
Pin 9	white/black	Output D8
Pin 10	green/brown	Output D9
Pin 11	green/grey	Zero setting
Pin 12	blue	GND
Pin 13	yellow	ENABLE
Pin 14	brown	UP/DOWN
Pin 15	red	UB
Pin 16	pink	STORE

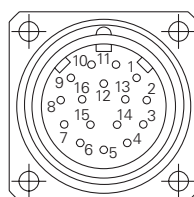

Trigger level	
Control inputs	Input circuit
Input level High	>0.7 UB
Input level Low	<0.3 UB
Input resistance	10 kΩ
Parallel outputs	Output circuit
	Push-pull circuit-proof
Output level High	>UB -3.5 V (I = -20 mA)
Output level Low	<0.5 V (I = 20 mA)
Load High	<-30 mA
Load Low	<30 mA
Tristate	<10 μA

Absolute encoders - parallel

Shaft with clamping or synchro flange

Optical singleturn encoders 10 bit, gray or binary

GA210, GA211 - parallel

Dimensions

GA210 - clamping flange

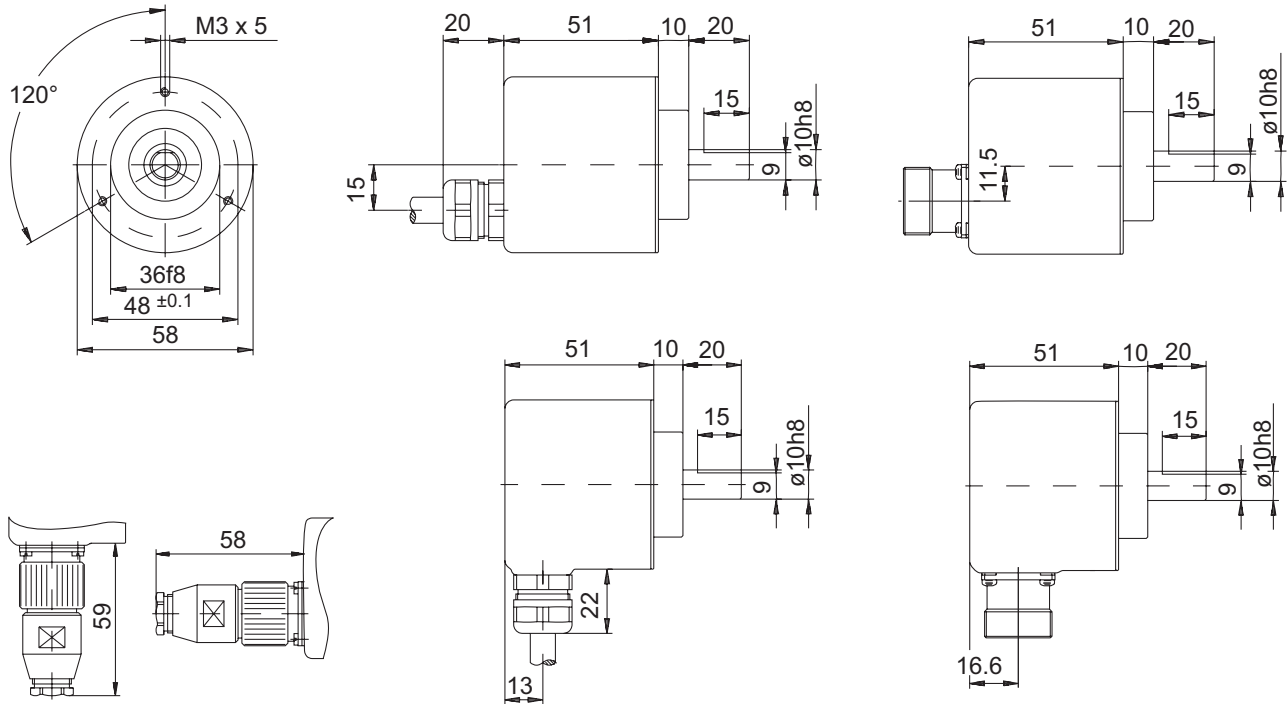

GA211 - synchro flange

