

Absolute encoders - SSI

Shaft max. $\varnothing 10$ mm

Magnetic single- or multiturn encoders 12 bit ST / 13 bit MT

BMSV 42, BMMV 42 SSI - MAGRES



BMMV 42 SSI with shaft

Technical data - electrical ratings

Voltage supply	5 VDC ± 10 % 10...30 VDC
Consumption w/o load (typ.)	100 mA (5 VDC) 50 mA (24 VDC)
Initializing time (typ.)	170 ms after power on
Interface	SSI
Steps per turn	4096 / 12 bit
Absolute accuracy	$\pm 1^\circ$
Sensing method	Magnetic
Code	Gray or binary
Code sequence	CW: ascending values with clockwise sense of rotation (looking at flange)
Inputs	SSI clock Reset input
Output circuit	SSI data: linedriver RS485
Interference immunity	DIN EN 61000-6-2
Emitted interference	DIN EN 61000-6-3
Approval	UL approval / E217823
BMSV 42	
Function	Singleturn
BMMV 42	
Function	Multiturn
Number of turns	8192 / 13 bit

Features

- Mini encoder single- or multiturn / SSI
- Magnetic sensing
- Resolution: singleturn 12 bit, multiturn 13 bit
- Housing $\varnothing 42$ mm
- High resistance to shock and vibrations
- Reset input
- Shaft $\varnothing 10$ mm or $\varnothing 6$ mm

Technical data - mechanical design

Dimensions (flange)	$\varnothing 42$ mm
Shaft	$\varnothing 6$ mm $\varnothing 10$ mm
Protection DIN EN 60529	IP 65
Operating speed	≤ 12000 rpm (mechanical) ≤ 6000 rpm (electric)
Shaft loading	≤ 10 N axial ≤ 25 N radial
Materials	Housing: steel Flange: aluminium
Operating temperature	$-20 \dots +85$ °C
Relative humidity	95 %
Resistance	DIN EN 60068-2-6 Vibration 30 g, 10-2000 Hz DIN EN 60068-2-27 Shock 500 g, 6 ms
Connection	Connector M12, 8-pin Cable
BMSV 42	
Operating torque typ.	0.0093 Nm
Weight approx.	120 g
BMMV 42	
Operating torque typ.	0.026 Nm
Weight approx.	190 g

Absolute encoders - SSI

Shaft max. $\varnothing 10$ mm

Magnetic single- or multiturn encoders 12 bit ST / 13 bit MT

BMSV 42, BMMV 42 SSI - MAGRES

Part number

Singleturn

BMSV 42S1 12/00

Connection
 5 Cable radial
 N Connector M12,
 5-pin, radial
 Shaft
 C6 $\varnothing 6$ mm, IP 65
 C0 $\varnothing 10$ mm, IP 65
 Resolution
 12/00 12 bit singleturn
 Voltage supply / signals
 05C 5 VDC / SSI
 24C 10...30 VDC / SSI
 Code
 N Binary code
 G Gray code

Multiturn

BMMV 42S1 12/13

Connection
 5 Cable radial
 N Connector
 M12, 5-pin,
 radial
 Shaft
 C6 $\varnothing 6$ mm, IP 65
 C0 $\varnothing 10$ mm, IP 65
 Resolution
 12/13 12/13 bit single-/multiturn
 Voltage supply / signals
 05C 5 VDC / SSI
 24C 10...30 VDC / SSI
 Code
 N Binary code
 G Gray code

Data transfer

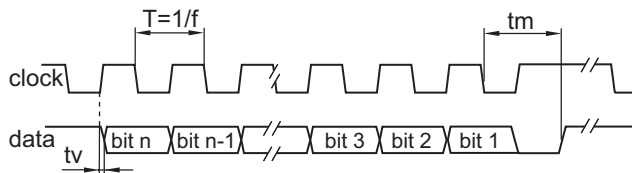

Clock frequency f	100...1000 kHz
Scan ratio of T	40...60 %
Time lag tv	200 ns
Monoflop time tm	20 μ s + T/2

Accessories

Connectors and cables

10146775	Female connector M12, 8-pin, straight
10127844	Female connector M12, 8-pin, straight, shielded, 2 m
10129332	Female connector M12, 8-pin, straight, shielded, 5 m cable

Mounting accessories

10110616	Clamp set
11053277	Bellows coupling aluminium/stainless steel 10 mm

Absolute encoders - SSI

Shaft max. $\varnothing 10$ mm

Magnetic single- or multturn encoders 12 bit ST / 13 bit MT

BMSV 42, BMMV 42 SSI - MAGRES

Terminal significance

+Vs	Encoder supply voltage.
0 V	Encoder ground connection relating to +Vs.
Data+	Positive, serial data output of differential linedriver.
Data-	Negative, serial data output of differential linedriver.
Clock+	Positive SSI clock input. Clock+ together with Clock- forms a current loop. A current of approx. 7 mA towards Clock+ input means logic 1 in positive logic.
Clock-	Negative SSI clock input. Clock- together with Clock+ forms a current loop. A current of approx. 7 mA towards Clock- input means logic 0 in positive logic.
Zero	Input for setting a zero point anywhere within the encoder resolution. The zero setting operation is triggered by a Low impulse. Connect to +Vs after setting operation for maximum interference immunity. Impulse duration >2 ms.
Rot. direction	Ascending position values when looking at the flange and rotating the shaft clockwise.

Trigger level

Control inputs	Input circuit
Input level Low	<0,4 V (>2 ms)
Input level High	+Vs or open

Terminal assignment

Cable

for connection reference **-5**

Core colour	Signals	Description
brown	+Vs	Supply voltage
white	0 V	Supply voltage
grey	Data+	Data signal
pink	Data-	Data signal
green	Clock+	Clock signal
yellow	Clock-	Clock signal
blue	Zero	Zero setting input
red	d.u.	do not use
Screen	connected to housing	
Cable data	8 x 0.14 mm ²	

Connector M12 male

for connection reference **-N**

Connector	Signals	Description
Pin 1	0 V	Supply voltage
Pin 2	+Vs	Supply voltage
Pin 3	Clock+	Clock signal
Pin 4	Clock-	Clock signal
Pin 5	Data+	Data signal
Pin 6	Data-	Data signal
Pin 7	Zero	Zero setting input
Pin 8	d.u.	do not use

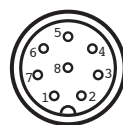

Absolute encoders - SSI

Shaft max. $\varnothing 10$ mm

Magnetic single- or multiturn encoders 12 bit ST / 13 bit MT

BMSV 42, BMMV 42 SSI - MAGRES

Dimensions

BMSV 42 SSI shaft 6 mm, cable radial

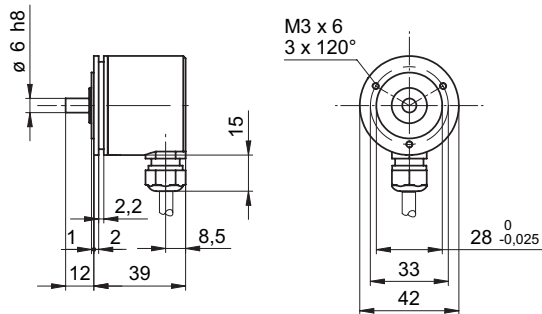

BMSV 42 SSI shaft 6 mm, connector M12 radial

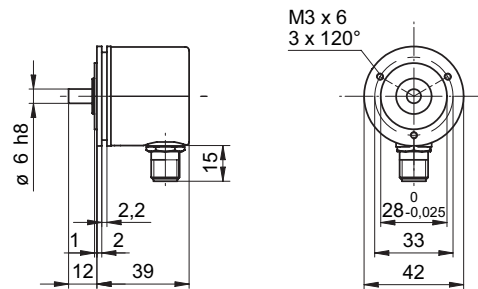

BMSV 42 SSI shaft 10 mm, cable radial

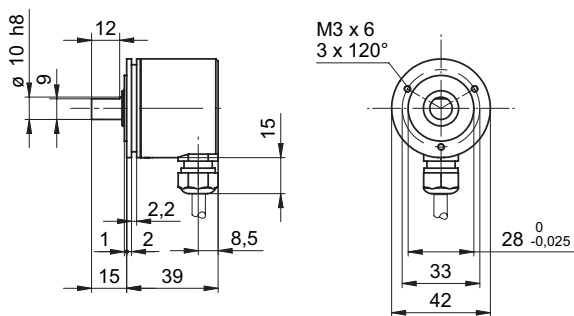

BMSV 42 SSI shaft 10 mm, connector M12 radial

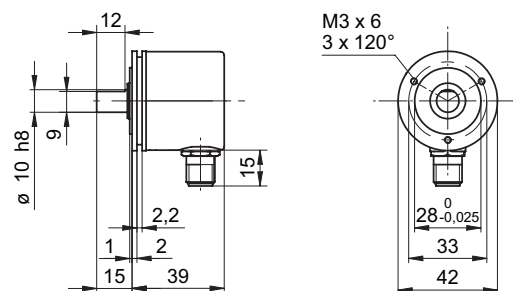

BMMV 42 SSI shaft 6 mm, cable radial

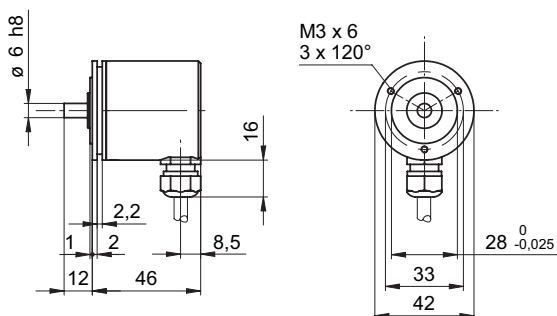

BMMV 42 SSI shaft 6 mm, connector M12 radial

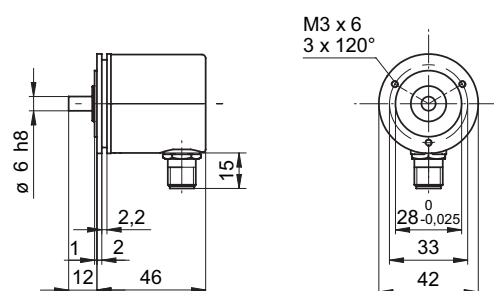

BMMV 42 SSI shaft 10 mm, cable radial

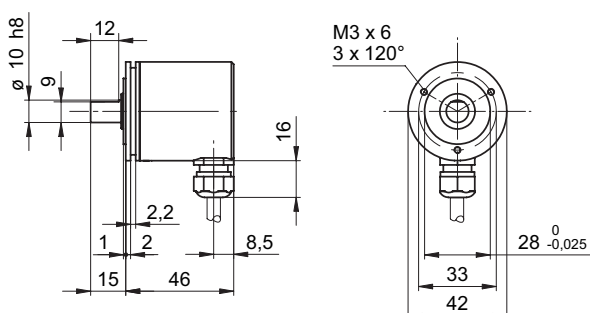

BMMV 42 SSI shaft 10 mm, connector M12 radial

