

Absolute encoders - bus interfaces

Shaft with clamping or synchro flange

Optical multiturn encoders 13 bit ST / 12 bit MT, Interbus

GXP6W



GXP6W with clamping flange

Features

- Encoder multiturn / Interbus
- Optical sensing
- Resolution: singleturn 13 bit, multiturn 12 bit
- Clamping or synchro flange
- Interbus encoder profile 71
- ENCOM profile K3
- High reliability by self-diagnostics
- Zero point, offset and turning direction programmable

Optional

- Transmission rate 2 MBaud

Technical data - electrical ratings

Voltage supply	10...30 VDC
Reverse polarity protection	Yes
Consumption w/o load	≤60 mA (24 VDC)
Initializing time (typ.)	50 ms after power on
Interface	Interbus
Function	Multiturn
Transmission rate	500 kBaud
Profile conformity	Encoder profile 71
Steps per turn	≤8192 / 13 bit
Number of turns	≤4096 / 12 bit
Absolute accuracy	±0.025 °
Sensing method	Optical
Code	Gray or binary
Code sequence	CW default, programmable
Output circuit	RS485
Interference immunity	DIN EN 61000-6-2
Emitted interference	DIN EN 61000-6-4
Programmable parameters	Total resolution Rotating direction and code Preset and offset Zero point setting
Approval	UL approval / E63076

Technical data - mechanical design

Dimensions (flange)	ø58 mm
Shaft	ø10 mm (clamping flange) ø6 mm (synchro flange)
Flange	Clamping or synchro flange
Protection DIN EN 60529	IP 54 (without shaft seal), IP 65 (with shaft seal)
Operating speed	≤10000 rpm (mechanical) ≤6000 rpm (electric)
Starting torque	≤0.015 Nm (IP 54) ≤0.03 Nm (IP 65)
Rotor moment of inertia	20 gcm ²
Shaft loading	≤20 N axial ≤40 N radial
Materials	Housing: aluminium Flange: aluminium
Operating temperature	-25...+85 °C -40...+85 °C (optional)
Relative humidity	95 % non-condensing
Resistance	DIN EN 60068-2-6 Vibration 10 g, 16-2000 Hz DIN EN 60068-2-27 Shock 200 g, 6 ms
Weight approx.	600 g
Connection	Connector M23, 2 x 9-pin

Absolute encoders - bus interfaces

Shaft with clamping or synchro flange

Optical multiturn encoders 13 bit ST / 12 bit MT, Interbus

GXP6W

Terminal significance

D01, $\overline{D01}$ D11, $\overline{D11}$	Arriving remote bus (galvanically isolated).
GND I	Ground connection for arriving remote bus (galvanically isolated).
UB GND B	Connections for voltage supply UB carried by bus, current load between arriving and departing connections max. 700 mA.
D02, $\overline{D02}$ D12, $\overline{D12}$	Outgoing remote bus.
GND	Ground connection for ongoing remote bus.
PE	Shield connected to encoder housing.
RBST	Input for recognition of other bus users. Connection open: final user connected to GND: user X.

Terminal assignment

M23 connector

Male connector	Assignment	Female connector	Assignment
Pin 1	D01	Pin 1	D02
Pin 2	$\overline{D01}$	Pin 2	$\overline{D02}$
Pin 3	D11	Pin 3	D12
Pin 4	$\overline{D11}$	Pin 4	$\overline{D12}$
Pin 5	GND I	Pin 5	GND
Pin 6	PE	Pin 6	PE
Pin 7	UB	Pin 7	UB
Pin 8	GND B	Pin 8	GND B
Pin 9	–	Pin 9	RBST

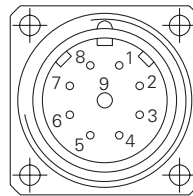

Arriving interface
(male connector)

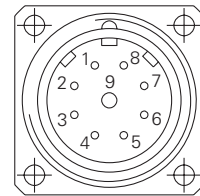

Departing interface
(female connector)

Bus cover

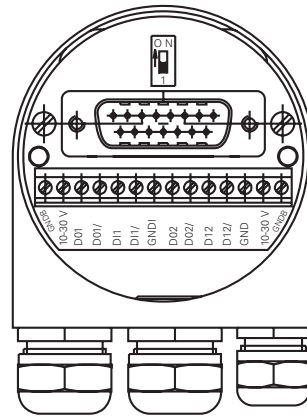

Termination



ON = Final user
OFF = User X

Absolute encoders - bus interfaces

Shaft with clamping or synchro flange

Optical multiturn encoders 13 bit ST / 12 bit MT, Interbus

GXP6W

Dimensions

GXP6W - clamping flange / connector M23 radial

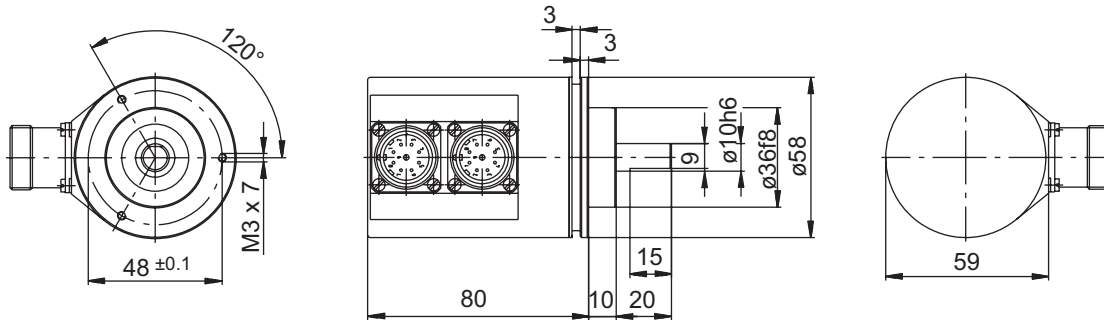

GXP6W - clamping flange / connector M23 axial

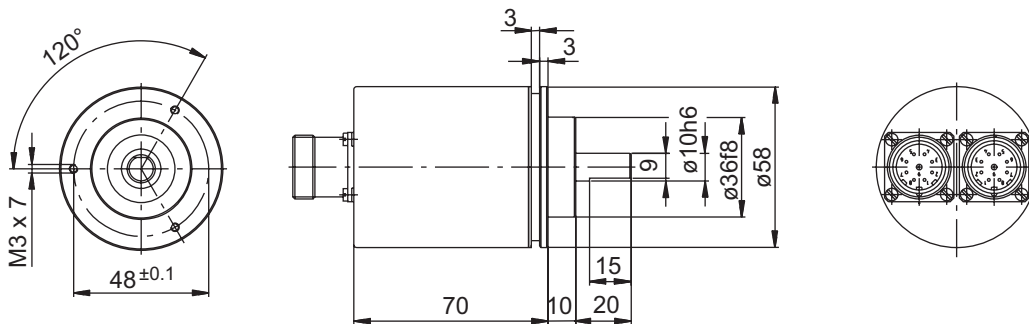

GXP6W - clamping flange / bus cover

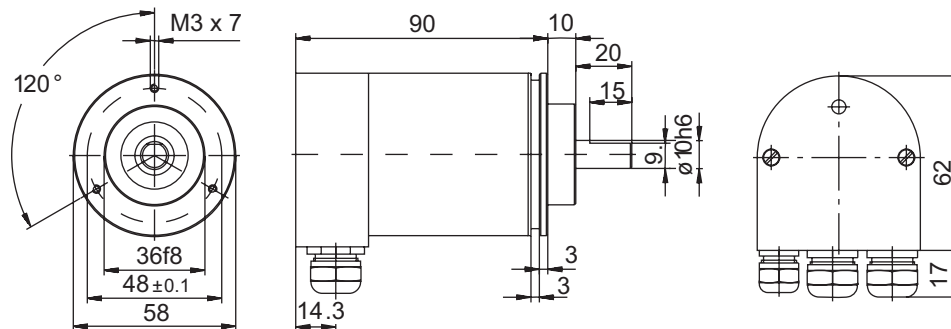

GXP6W - synchro flange

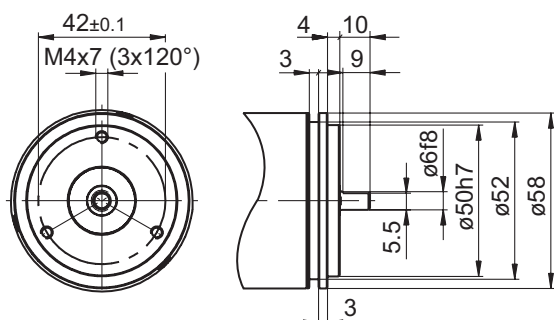

GXP6W - connector dimensions

