

TE2 - Pt100 Temperature Sensors

Case in stainless steel

Wetted parts in acid-proof, stainless steel or PEEK

Wide range of process connections

Pt100 sensors, single or duplex element

DIN A or B (1/1 or 1/3) elements

Standard or fast response sensor tip

Electrical connection M12 or DIN43650 plug

Available with all CombiTemp sensors

Option:

Integrated PC-configurable temperature transmitter



Description

The TE2 Pt100 temperature sensor system has a stainless steel case with a build-in plug.

All models can be supplied with an integrated, configurable temperature transmitter with 4...20 mA output.

The system complies with standard industrial process connections as well as hygienic connections with high cleanability and bacteria tightness.

Fast response sensor tip ensures accurate measurements. DIN A or B, single or double elements.

The M12 process connection can be supplied with a PEEK cone for tightening (chuck cone). The FDA-approved PEEK material has very unique characteristics, such as high elasticity, non-floating and extremely resistant against abrasive and corrosive media. That makes it ideal for hygienic process applications.

The non-hygienic process connections are used in the general industry such as measurements on water and steam whereas the hygienic connections are ideal in CIP systems, breweries, dairies and in the pharmaceutical industry.

For the models TE2x1...TE2x6 please refer to the data sheet "Accessories, Universal" describing a wide range of hygienic welding parts and other accessories.

For model TE20Z please refer to the data sheet "2000-1" describing CombiTemp Pt100 sensors.

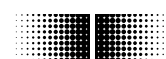

Baumer

Technical Data - Temperature Sensor

Environmental conditions

Media temperature, std.	-50...200°C, note {5}
Ambient temperature	-40...85°C
Humidity	< 100% RH, condensing
Protection class	M12: IP 67 ; DIN 43650: IP65

Sensor element

Sensor type	Pt100, Class A or B
Accuracy	DIN/EN/IEC 60751
1/1 DIN B	$\pm(0.3 + 0.005 \times t) \text{ }^\circ\text{C}$
1/3 DIN B	$\pm 1/3 \times (0.3 + 0.005 \times t) \text{ }^\circ\text{C}$
1/1 DIN A	$\pm(0.15 + 0.002 \times t) \text{ }^\circ\text{C}$
Wiring	$\varnothing 0,5$ silver wire

Sensor tube, connection and case

Material	Stainless steel
Case, $\varnothing 18$ mm	W.1.4301 (AISI 304)
Wetted parts	W1.4404 (AISI 316L) Other materials upon request
PEEK (Poly Ether Ether Keton)	-50...250°C, FDA approved
Media pressure	Max. 16 bar
Time constant t_{50} (in water)	Sensor tip: $\varnothing 6$ mm 3.0 sec. $\varnothing 4$ mm 2.5 sec. $\varnothing 3$ mm 1.3 sec. Conical sensor <1.0 sec.
Vibrations	IEC 68-2-6, GL test2
Mechanical tolerances	ISO 2768-m

Temperature Curve

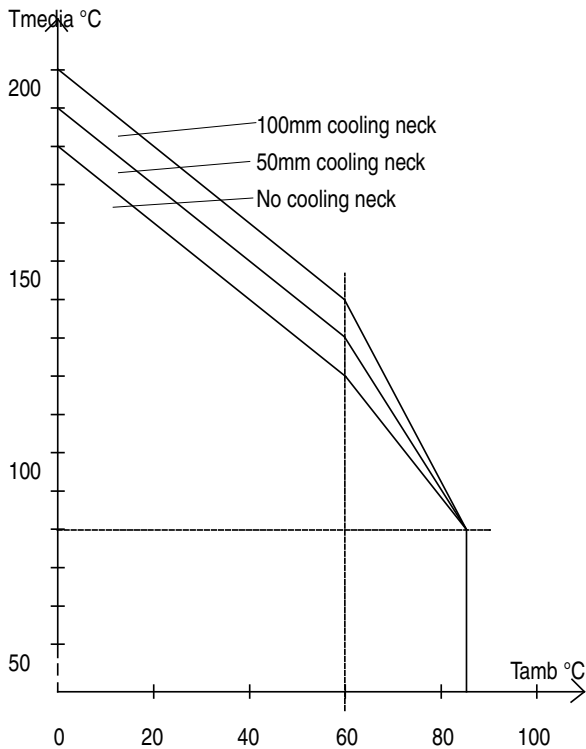

Technical Data for the Integrated Transmitter

Input

Accuracy	< 0.25°C {2}
Sample time	< 0.7 sec.
Pt100 Standard	IEC/DIN/EN 60 751-2
RTD measuring current	0.3 mA, continuously
Error detection delay	< 10 sec.
Measuring unit	°C or °F {1}
Minimum span	25°C
Protection	+/- 35 V _{dc}
Suppression	50 and 60 Hz
Resolution	14 bit
Repeatability	< 0.1°C
Ripple immunity	IEC 770 6.2.4.2
Offset Adjustment	Max. $\pm 10^\circ\text{C}$ {1}
Isolation, sensor to case	50 Vac (test 500V)

Output

Signal span	4...20 mA, 2-wire
Accuracy	< 0.1% of signal span
Supply range	8...35 V _{dc}
Ripple immunity	3 V _{rms}
Load equation	$R_L \leq (V_{dc} - 8)/23$ [kOhm]
Up/Down scaling limits	23 mA/3.5 mA {1}
Damping	0...30 sec. {1}
Protection	Reversed polarity protection
Resolution	12 bit
Effect of variations in supply voltage:	
Output current	0.01% per volt
TAG No.	15 characters {1}

Environmental conditions

Operating temperature	-40...85°C
Storage temperature	-55...90°C
Long-term test	IEC 770 6.3.2

EMC data

Generic standards	EN 61000-6-3, EN61000-6-2
Product standard	EN 61326
Namur	NE21

Other data

Temperature drift	Typ. 0.003% per °C Max. 0.01% per °C
Power-on time	20 sec.

Disposal of product and packing

According to national laws or by returning to Baumer

Notes

{1}	Configurable
{2}	Lower range limit $\leq 100^\circ\text{C}$

Ordering Details - TE2 Series Temperature Sensor/Transmitter

	TE2x	x	xxxx	xxxx (C)
Sensor tip	4' digit			
Not specified	0			
Normal response sensor tip, ø6 mm {10}	1			
Fast response sensor tip, ø4 mm, Note {3} {9} {10}	2			
Fast response sensor tip, ø3 mm, Note {3} {9}	3			
Process Connection, Note {4}	5' digit			
Sensor tube without thread (Vibration test not valid)	1			
G1/2A Male nipple, ISO 228/1	3			
G1/2A Male nipple, Hygienic, ISO 228/1	4			
M12 x 1.5 Male nipple, Hygienic, ISO 228/1	5			
M12 x 1.5 Male nipple, Hygienic, PEEK cone, ø3 x 5 mm sensor tip (Order: TE20-6-xxxx-0000-x)	6			
Conical sensor, ø3 x 20mm or 25 mm sensor tip {7} {9} (Order: TE20-7-xxxx-0000-x)	7			
CombiTemp sensor {8}	Z			
Sensor element	6' digit			
Not specified	0			
Pt100, 1/1 DIN B, single, specified accuracy -50...400°C	1			
Pt100, 1/1 DIN B, duplex, specified accuracy -50...400°C {11}	2			
Pt100, 1/3 DIN B, single, specified accuracy 0...150°C	3			
Pt100, 1/3 DIN B, duplex, specified accuracy 0...150°C {11}	4			
Pt100, 1/6 DIN B, single, specified accuracy 0...100°C	5			
Pt100, 1/1 DIN A, single, specified accuracy -50...300°C	7			
Pt100, 1/1 DIN A, duplex, specified accuracy -50...300°C {11}	8			
Cooling neck	7' digit			
No cooling neck	0			
Cooling neck, 50 mm, Note {5} {10}	1			
Cooling neck, 100 mm, Note {5} {10}	2			
Electrical connection	8' digit			
M12 plug, 4 pole, nickel plated brass	1			
M12 plug, 4 pole, with integrated temperature transmitter	2			
DIN43650-A, incl. 3 pole plug	4			
DIN43650-A, with integrated temperature transmitter, incl. 3 pole plug {10}	5			
M12 plug, 4 pole, stainless steel	6			
Certificates	9' digit			
Not specified	0			
Calibration certificate	2			
Sensor tube length (L)	10...13' digit			
CombiTemp sensor (selected in 5' digit) {8}			0000	
Length in mm. Observe max. lengths and special sensors			xxxx	
Configuration, if relevant	(14' digit)			
Configuration according to customer specifications {1} {6}				(C)

Notes

- | | |
|---|--|
| <p>{3} Sensor tube length 35...300 mm. Refer to drawings.</p> <p>{4} Welding part is not included.</p> <p>{5} A cooling neck is necessary for an insulated tank or if the ambient temperature at the housing exceeds the max. temperature for head and/or transmitter. Refer to the curve.</p> <p>{6} Specify configuration data and add "C" to the type number.</p> <p>{7} Standard sensor tip lengths 20 mm and 25 mm (max.). Select tip length in digits 10...13, ex. 0025</p> | <p>{8} In case you need a CombiTemp sensor, select type no. "TE20 Z 00x0 0000" in this data sheet and type no. 814x xxx1 x000 00x xxxx in the CombiTemp data sheet 2000-1. Selections should be made for the digits marked with an "x".</p> <p>{9} Single, 2-wire sensor element only.</p> <p>{10} Not valid for conical sensor (TE23 7 x0xx 00xx)</p> <p>{11} Double element not valid with transmitter</p> |
|---|--|

Dimensional Drawings - Mounting Details

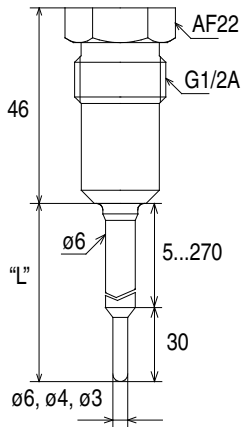
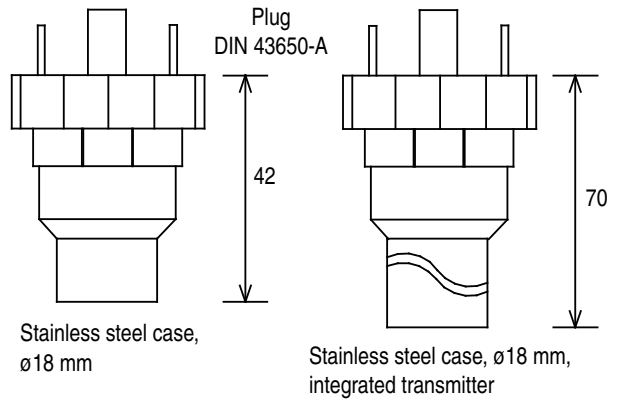
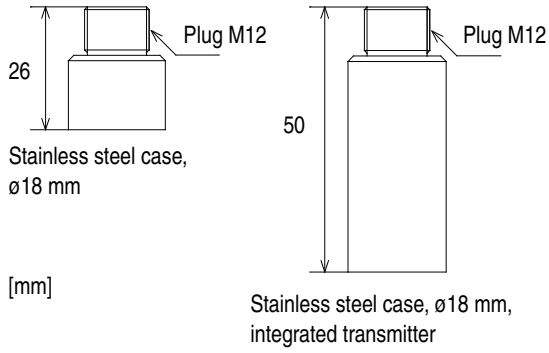

G1/2A male nipple, hygienic (welding part PM020)

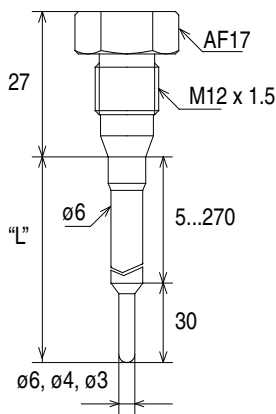

M12 male nipple, hygienic (welding part PM031)

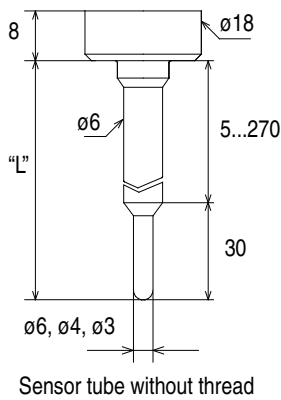

Sensor tube without thread

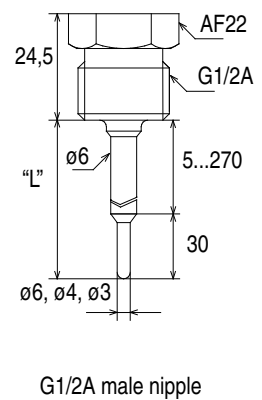

G1/2A male nipple

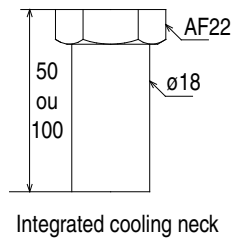

Integrated cooling neck

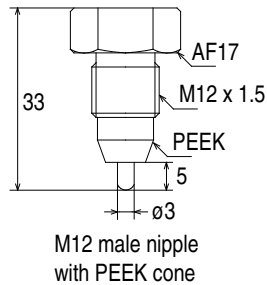

M12 male nipple with PEEK cone

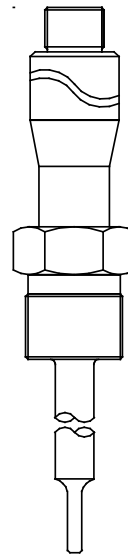

TE2 case with or without transmitter

7.5 mm to be added to housing length

This example shows a TE2 assembled with a CombiTemp process connection type no. : 8142 3211 0000 000 xxxx. Refer to data sheet 2000-1 for further data.

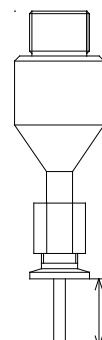
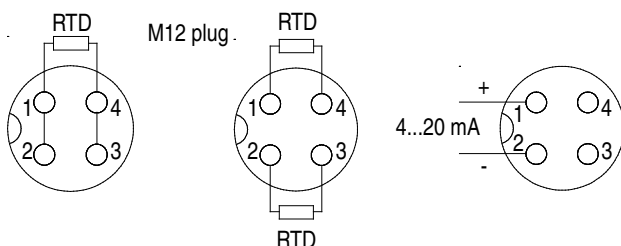
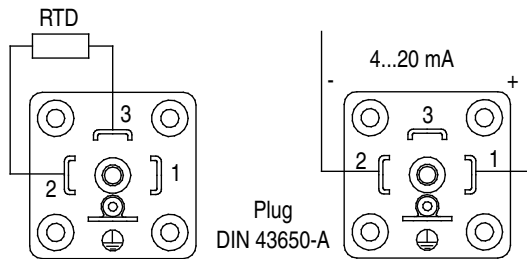

TE2 case

TE2 with a conical sensor. TE20 7 x0xx 00xx. Illustrated with welding part type no. 81 55-292

20 or 25 mm

Accessories

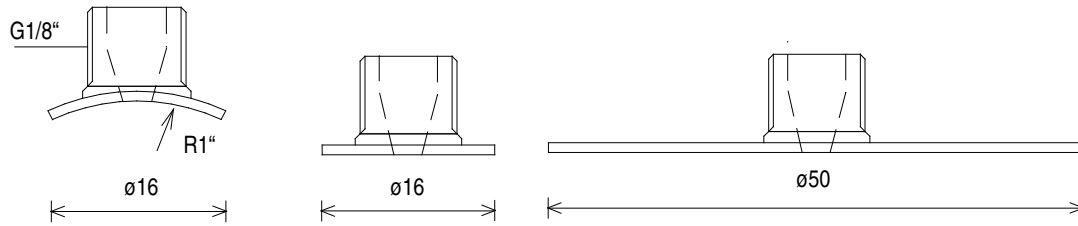

Welding nipple for conical sensor
 Welding nipple for conical sensor
 Welding nipple for conical sensor
 Blind plug for welding nipple

G 1/8, R=1"
 G 1/8, flat, \varnothing 16 mm
 G 1/8, flat, \varnothing 50 mm

Type no. 8155-291
 Type no. 8155-292
 Type no. 8155-294
 Type no. 8155-293

Adapter cable, TE2/M12 for FlexProgrammer
 FlexProgrammer, dedicated configuration tool
 ZED 601, configurable digital indicator See data sheet

Type no. 9000 0017
 Type no. 8223-903



TE2 with conical sensor

Application Examples

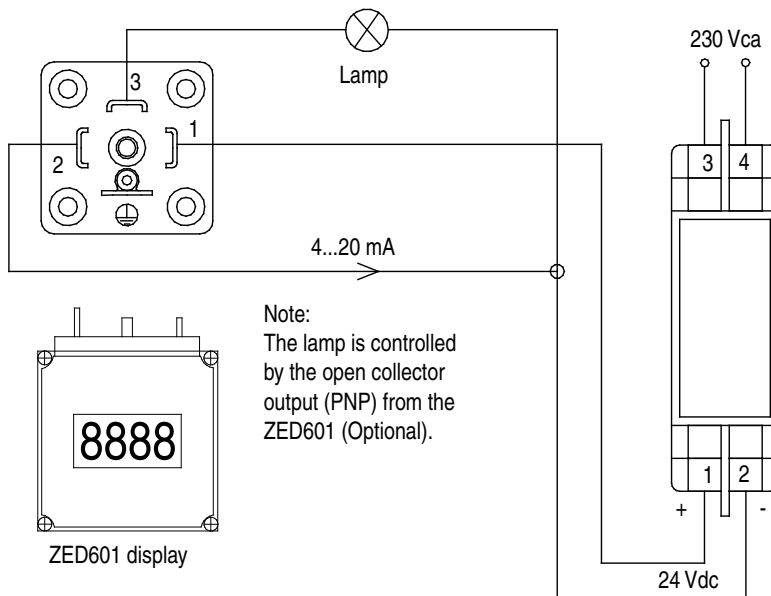

TE2 with G1/2 connection.
 Integrated transmitter.
 Display ZED601.
 DIN43650A plug.



TE2 with M12 hygienic PEEK process connection.
 Integrated transmitter.
 DIN43650A plug.



TE2 with G1/2 sensor
 Integrated transmitter. M12 plug

Configuration

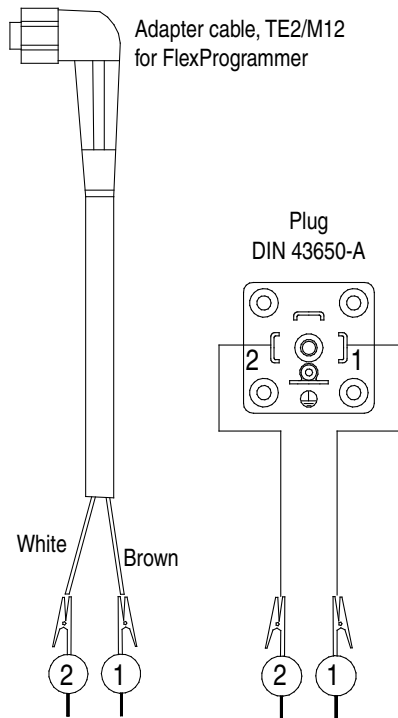

FlexProgrammer 9701

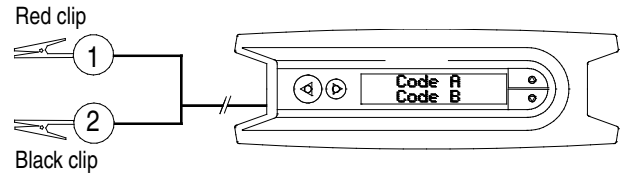

Accessories



The FlexProgrammer 9701-0001 is a dedicated tool to configure all Baumer configurable products.